

SWMA Specifications and Tolerances (S&T) Committee 2022 Annual Meeting Report

Mr. Mark Lovisa, Committee Chair
Louisiana

INTRODUCTION

The S&T Committee will address the following items in Table A during the Interim Meeting. Table A identifies the agenda items by reference key, title of item, page number and the appendices by appendix designations. The headings and subjects apply to *Handbook 44 Specifications, Tolerances, and Other Technical Requirements for Weighing and Measuring Devices*. The first three letters of an item's reference key are assigned from the Subject Series List. The next 2 digits represent the year the item was introduced. The acronyms for organizations and technical terms used throughout the agenda are identified in Table B.

An "Item Under Consideration" is a statement of proposal and not necessarily a recommendation of the Committee. Suggested revisions are shown in **bold face print** by ~~striking out~~ information to be deleted and **underlining** information to be added. Requirements that are proposed to be nonretroactive are printed in *bold faced italics*. Additional letters, presentations and data may have been part of the committee's consideration. Please refer to www.ncwm.com/publication-15 to review these documents.

In some cases, there may be proposed changes affecting multiple model laws or regulations that share the same purpose or proposed changes to one model law or regulation may be dependent on the adoption of proposed changes to another. The Committee may group such items into "Blocks" to facilitate efficient handling for open hearings and voting. These blocks are identified in Committee's agenda.

Note: It is policy to use metric units of measurement in publications; however, recommendations received by NCWM technical committees and regional weights and measures associations have been printed in this publication as submitted. Therefore, the report may contain references to inch-pound units.

Subject Series List

Handbook 44 – General Code.....	GEN Series
Scales.....	SCL Series
Belt-Conveyor Scale Systems	BCS Series
Automatic Bulk Weighing Systems	ABW Series
Weights.....	WTS Series
Automatic Weighing Systems	AWS Series
Weigh-In-Motion Systems used for Vehicle Enforcement Screening.....	WIM Series
Liquid-Measuring Devices	LMD Series
Vehicle-Tank Meters	VTM Series
Liquefied Petroleum Gas and Anhydrous Ammonia Liquid-Measuring Devices	LPG Series
Hydrocarbon Gas Vapor-Measuring Devices.....	HGV Series
Cryogenic Liquid-Measuring Devices.....	CLM Series
Milk Meters	MLK Series
Water Meters	WTR Series
Mass Flow Meters	MFM Series
Carbon Dioxide Liquid-Measuring Devices.....	CDL Series
Hydrogen Gas-Metering Devices	HGM Series
Electric Vehicle Refueling Systems	EVF Series
Vehicle Tanks Used as Measures	VTU Series
Liquid Measures	LQM Series
Farm Milk Tanks	FMT Series
Measure-Containers.....	MRC Series
Graduates.....	GDT Series
Dry Measures	DRY Series
Berry Baskets and Boxes.....	BBB Series
Fabric-Measuring Devices.....	FAB Series
Wire-and Cordage-Measuring Devices	WAC Series
Linear Measures	LIN Series
Odometers	ODO Series
Taximeters.....	TXI Series
Timing Devices	TIM Series
Grain Moisture Meters (a).....	GMA Series
Grain Moisture Meters (b).....	GMB Series
Near-Infrared Grain Analyzers.....	NIR Series
Multiple Dimension Measuring Devices.....	MDM Series
Electronic Livestock, Meat, and Poultry Evaluation Systems and/or Devices.....	LVS Series
Transportation Network Measuring Systems	TNS Series
Other Items	OTH Series

**Table A
Table of Contents**

Reference Key	Title of Item	S&T Page
GEN – GENERAL CODE 158		
GEN-23.1	G-N.3. Test Methods	158
SCL – SCALES 161		
SCL-23.1	S.1.12. Manual Weight Entries	161
SCL-23.2	Table S.6.3.a. Marking Requirements, and Table S.6.3.b. Notes for Table S.6.3.a. Marking Requirements	163
SCL-22.2	A UR.1. Selection Requirements, UR.1.X. Cannabis.....	165
WIM – WEIGH-IN-MOTION SYSTEMS – TENTATIVE CODE 169		
WIM-23.1	Remove Tentative Status and Amend Numerous Sections Throughout	169
LMD – LIQUIDE MEASURING DEVICES 180		
LMD-23.3	Automatic Temperature Compensation Task Group	180
LMD-23.4	N.3.5. Wholesale Devices.....	181
VTM – VEHICLE TANK METERS 186		
VTM-18.1	S.3.1 Diversion of Measured Liquid and S.3.1.1. Means for Clearing the Discharge Hose and UR.2.6. Clearing the Discharge on a multiple-product, single discharge hose.....	186
VTM-20.2	A Table T.2. Tolerances for Vehicle Mounted Milk Meters.	194
LPG – LIQUIFIED PETROLEUM GAS AND ANHYDROUS AMMONIA LIQUID-MEASURING DEVICES..... 201		
LPG-22.3	D <i>S.2.5. Zero-Set-Back Interlock., S.2.5.2. Zero -Set-Back Interlock for Stationary Customer -Operated Electronic Retail Motor-Fuel Devices.</i>	202
LPG-23.1	S.2.5. Zero-Set-Back Interlock	207
LPG-23.2	S.2.6. Automatic Timeout.....	210
LPG-15.1	D N.3. Test Drafts.....	212
MLK – MILK METERS 220		
MLK-23.2	Table T.1. Tolerances for Milk Meters	220
MFM – MASS FLOW METERS 223		
MFM-15.1	D N.3. Test Drafts.....	223
HGM – HYDROGEN GAS-MEASURING DEVICES 230		
HGM-23.1	UR.3.8. Safety Requirement.....	230
EVF – ELECTRIC VEHICLE FUELING SYSTEMS 233		
EVF-21.1	D A.1. General.....	233
EVF-21.5	D T.2. Load Test Tolerances.	237
EVF-23.1	S.2.5.1., S.8., S.5.3.(d), N.1., T.5., N.2., T.6., Appendix D – Definitions; megajoule (MJ)	241
EVF-23.2	S.2.7. Indication of Delivery.....	245
EVF-23.3	S.2.7. Indication of Delivery.....	247
EVF-23.4	S.5. Markings, and N.5. Test of an EVSE System.....	249
EVF-23.5	S.5.2. EVSE Identifications and Marking Requirements, and T.2. Load Accuracy Test tolerances.	254
EVF-23.6	S.5.2. EVSE Identification and Marking Requirements., and T.2. Tolerances.....	257
EVF-23.7	N.1. No Load Test, N.2. Start in Load Test, N.5.2. Accuracy Testing, And Appendix D: maximum deliverable amperes.	265

GMA – GRAIN MOISTURE METERS 5.56 (A)	269
GMA-19.1 D Table T.2.1. Acceptance and Maintenance Tolerances Air Oven Method for All Grains and Oil Seeds.	269
GMA-23.1 N.1.3. Meter to Like-Meter Method Transfer Standards and Table T.2.2. Acceptance and Maintenance Tolerances Meter to Like-Meter Method.....	272
MDM – MULTIPLE DIMENSION MEASURING DEVICES	275
MDM-22.1 D S.1.7. Minimum Measurement.	275
OTH – OTHER ITEMS 277	
OTH-16.1 D Electric Watthour Meters Code under Development.....	277
BLOCK 1 ITEMS (B1) MINIMUM DRAFT SIZE WHEN USING A FIELD STANDARD METER	282
B1: LMD-23.1 N.3.5. Wholesale Devices.....	282
B1: VTM-23.1 N.3. Test Drafts.....	282
B1: MLK-23.1 N.3. Test Drafts.....	282
BLOCK 2 ITEMS (B2) DEFINE TRUE VALUE FOR USE IN ERROR CALCULATIONS	285
B2: SCL-20.3 A S.5.4. Relationship of Minimum Load Cell Verification Interval to the Scale Division	286
B2: SCL-20.4 A Table 3. Parameters of Accuracy Classes.	286
B2: SCL-20.5 A Table S.6.3.a. Marking Requirements, Note 3.....	288
B2: SCL-20.6 A T.N.1.2. Accuracy Classes and T.N.1.3. Scale Division.....	288
B2: SCL-20.7 A Table 6. Maintenance Tolerances	288
B2: SCL-20.8 A Table 8. Recommended Minimum Load	289
BLOCK 3 ITEMS (B3) TOLERANCES FOR DISTANCE TESTING IN TAXIMETERS AND TRANSPORTATION NETWORK SYSTEMS	299
B3: TXI-20.1 D T. Tolerances	299
B3: TNS-20.1 D T. Tolerances	300
BLOCK 4 ITEMS (B4) ELECTRONICALLY CAPTURED TICKETS OR RECEIPTS	303
B4: GEN-21.2 D G-S.5.6. Recorded Representations.	303
B4: LMD-21.2 D S.1.6.5. Money Value Computations., UR.3. Use of a Device.	304
B4: VTM-21.1 D S.1.1. Primary Elements., UR.2. User Requirements	306
B4: LPG-21.1 D S.1.1. Primary Elements., UR.2. User Requirements	307
B4: CLM-21.1 D S.1.4.1. Printed Ticket Recorded Representation., UR.2.6.3. Printed Ticket Recorded Representation.	309
B4: MLK-21.1 D S.1.4.2. Printed Ticket Recorded Representation., UR.2.6.3. Printed Ticket Recorded Representation.	309
B4: MFM-21.2 D S.6. Printer Recorded Representations., UR.2.6. Ticket Printer, Customer Ticket, Recorded Representation., UR.3.4. Printed Ticket. Recorded Representation.	310
B4: CDL-21.1 D S.1.4.1. Printed Ticket Recorded Representations., UR.2.4.2. Tickets or Invoices. Recorded Representation.	311
B4: HGM-21.1 D S.2.6. Recorded Representations, Point of Sale Systems., S.6. Printer. Recording Element., UR.3.2. Vehicle-mounted Measuring Systems Ticket Printer Recording Element., UR.3.3. Printed Ticket. Recorded Representation.....	311
B4: OTH-21.2 D Appendix D - Definitions.: recorded representations, recording element.....	312
BLOCK 5 ITEMS (B5) TEST DRAFTS	315
B5: LMD-23.2 N.3.5. Wholesale Devices.....	315
B5: VTM-23.2 N.3. Test Drafts.....	316
BLOCK 6 ITEMS (B6) COMMERCIAL AND LAW ENFORCEMENT, AXLE AND AXLE GROUP WEIGHTS	318
B6: SCL-22.1 D Recorded Representation of Axle or Axle Group Weights.....	318
B6: SCL-22.3 D UR.3.3. Single-Draft Vehicle Weighing., and UR.3.4. Axle and Axle Group Weight Values.	319

BLOCK 7 ITEMS (B7) TOLERANCES ON TESTS USING TRANSFER STANDARDS.....324

B7: CLM-22.1 D T.3. On Tests Using Type 2 Transfer Standards..... 324

B7: CDL-22.1 D T.3. On Tests Using Type 2 Transfer Standards..... 324

B7: HGM-22.1 D T.4. Tolerance Application on Tests Using Type 2 Transfer Standard Test Method..... 324

BLOCK 8 ITEMS (B8) TOLERANCES ON TESTS USING TRANSFER STANDARDS, APPENDIX A - TOLERANCES FOR STADARDS, AND APPENDIX D – FIELD STANARDS AND TRANSFER STANDARDS327

B8: GEN-19.1 D G-T.5. Tolerances on Tests When Transfer Standards are Used., Appendix A, Section 3.2. Tolerances for Standards., and Appendix D – Definitions: standards, field., ~~transfer standard.~~ and standard, transfer. 328

B8: OTH-22.1 D Appendix A: Fundamental Considerations, 3. Testing Apparatus..... 329

Appendices

A Item Block 2 – Final Report of the Verification Scale Division Task Group..... A273

**Table B
Glossary of Acronyms and Terms**

Acronym	Term	Acronym	Term
ABWS	Automatic Bulk Weighing System	NEWMA	Northeastern Weights and Measures Association
AAR	Association of American Railroads	NIST	National Institute of Standards and Technology
API	American Petroleum Institute	NTEP	National Type Evaluation Program
CNG	Compressed Natural Gas	OIML	International Organization of Legal Metrology
CWMA	Central Weights and Measures Association	OWM	Office of Weights and Measures
EPO	Examination Procedure Outline	RMFD	Retail Motor Fuel Dispenser
FHWA	Federal Highway Administration	S&T	Specifications and Tolerances
GMM	Grain Moisture Meter	SD	Secure Digital
GPS	Global Positioning System	SI	International System of Units
HB	Handbook	SMA	Scale Manufactures Association
LMD	Liquid Measuring Devices	SWMA	Southern Weights and Measures Association
LNG	Liquefied Natural Gas	TC	Technical Committee
LPG	Liquefied Petroleum Gas	USNWG	U.S. National Work Group
MMA	Meter Manufacturers Association	VTM	Vehicle Tank Meter
MDMD	Multiple Dimension Measuring Device	WIM	Weigh-in-Motion
NCWM	National Conference on Weights and Measures	WWMA	Western Weights and Measures Association

Details of All Items
(In order by Reference Key)

1 **GEN – GENERAL CODE**

2 **GEN-23.1** **G-N.3. Test Methods**

3 **Source:**

4 Seraphin Test Measure Company

5 **Purpose:**

6 There are several proposals on the S&T agenda with the objective to recognize meters for use as field standards or
7 as transfer standards. This proposal offers an option to add a paragraph to the General Code to state that other field
8 standards and transfer standards may be approved by the State weights and measures Director for use to test
9 commercial devices, rather than adding paragraphs to each specific code for this purpose.

10 **Item Under Consideration:**

11 Amend Handbook 44, General Code, as follows:

12 **G-N.3. Test Methods. – Permissible test methods for verifying compliance of weighing and measuring**
13 **systems with the provisions of the General Code and Specific Codes include, but are not limited to, test**
14 **methods and apparatus that have been approved by the State Director of weights and measures as outlined**
15 **in Appendix A - Fundamental Considerations, Section 3. Testing Apparatus.**

16 **Previous Action:**

17 2023: New Item

18
19 **Original Justification:**

20 Several device codes already contain references regarding transfer standards used to test commercial measurement
21 devices (e.g., Cryogenic Liquid-Measuring Devices Code, Carbon Dioxide Liquid-Measuring Devices Code and
22 Hydrogen Gas-Measuring Devices Code). Rather than revising a specific code in Handbook 44 every time a new field
23 or transfer standard is proposed or developed, it is better to have an overall statement in the General Code that
24 recognizes the use of other field and transfer standards that meet the requirements for use as field or transfer standards.
25 The joint OWM/Seraphin proposal (GEN-19.1 and OTH-22.1) provides definitions and criteria to be included in
26 Handbook 44 and in the Fundamental Considerations in Appendix A. It also prescribes the tolerances to be applied
27 when using Type 2 transfer standards. For those who believe a specific statement in Handbook 44 is needed to
28 recognize additional field and transfer standards, the proposed addition of G-N.3. will provide the reference they want
29 without the need to change individual codes on a regular basis to recognize each particular field or transfer standard.

30 Some regulators may argue that if Handbook 44 does not specifically recognize a specific type of field or transfer
31 standard, then the use of the field or transfer standard is not allowed. However, this approach would mean that every
32 type of field or transfer standard must be specifically recognized in an H44 code and then the Handbook must be
33 changed every time a new standard is proposed to be recognized. The Fundamental Considerations already recognize
34 the authority of the Director to recognize new standards and transfer standards for use to test commercial devices.
35 Footnote 2 to Section 3.1. includes the statement, “This section shall not preclude the use of additional field standards
36 and/or equipment, as approved by the Director, for uniform evaluation of device performance.”

37
38 Others may argue that this paragraph in the General Code is not needed, since (1) the definitions of field standard and
39 transfer standard and (2) the Fundamental Considerations already provide for the recognition and use of other field
40 standards and transfer standards.

41 The submitter requests that this be a retroactive section.

1 **Requested Status by Submitter:** Voting Item

2 **Comments in Favor:**

3 **Regulatory:**

- 4 •

5 **Industry:**

- 6 •

7 **Advisory:**

- 8 •

9 **Comments Against:**

10 **Regulatory:**

- 11 •

12 **Industry:**

- 13 •

14 **Advisory:**

- 15 •

16 **Neutral Comments:**

17 **Regulatory:**

- 18 •

19 **Industry:**

- 20 •

21 **Advisory:**

- 22 •

23 **Item Development:**

24 New

25 Additional letters, presentation and data may have been submitted for consideration with this item. Please refer to
26 www.ncwm.com/publication-15 to review these documents.

GEN-23.1

Regional recommendation to NCWM on item status:

- Recommend as a Voting Item on the NCWM agenda
- Recommend as an Information Item on the NCWM agenda
- Recommend as an Assigned Item on the NCWM agenda
(To be developed by an NCWM Task Group or Subcommittee)
- Recommend as a Developing Item on the NCWM agenda
(To be developed by source of the proposal)
- Recommend Withdrawal of the Item from the NCWM agenda
(In the case of new proposals, do not forward this item to NCWM)
- No recommendation from the region to NCWM
(If this is a new proposal, it will not be forwarded to the national committee by this region)

Comments and justification for the regional recommendation to NCWM: *(This will appear in NCWM reports)*

The following comments were received during the 2022 SWMA Annual Meeting:

Dr. Matt Curran, State of Florida, commented that he wasn't clear on who the submitter of this item is. He cautioned that this item would allow the use of a device not in the handbook and would lay the burden of responsibility for the use of that device solely on the Director. He also stated concern that this would move us away from uniformity.

Mr. Robert Murnane of Seraphin Test Measures, the submitter of this item, stated that the Handbook already gives the Director the authority to use any device, and that this would make it easier to adopt new technologies as they are developed. He recommended moving this forward as a Voting item.

Mr. Tim Chesser, State of Arkansas, echoed Mr. Curran's concerns. He also stated that he liked the item, and that it would give us some teeth when making accommodations for alternate test methods.

Mr. Keilty, Endress + Hauser, stated that we discuss new technology and how to deal with it in every meeting. He added that lines 12-15 were redundant to S&T Block 8 page 310, lines 33-46. He also stated that this issue is ultimately addressed by the Fundamental Considerations and recommended that the item be withdrawn.

Mr. Hal Prince, State of Florida, stated that he didn't see a need for this proposal.

Mr. Ken Ramsburg, State of Maryland echoed Mr. Prince.

The SWMA S&T Committee believes that the need for this item is ambiguous, and that it would be redundant to Block 8 if those items are added to the handbook as well.

The SWMA S&T Committee recommends that this item move forward as a Developing Item.

1 **SCL – SCALES**

2 **SCL-23.1 S.1.12. Manual Weight Entries**

3 **Source:**
4 NTEP Weighing Sector

5 **Purpose:**
6 Provide Specifications corresponding with User Requirements that limit how manual weight entries are allowed.

7 **Item Under Consideration:**
8 Amend Handbook 44, Scales Code, as follows:

9 ***S.1.12. Manual Weight Entries.** – ~~A device w~~When being used ~~in a for~~ direct sale **application and when in a**
10 **zero-balance condition, a device or a Point-of-Sale System**** shall accept an entry of a manual gross or net
11 ~~weight value only when; **the scale gross or net* weight indication is at zero.**~~*

- 12
- 13 ***(a) a point-of-sale system interfaced with a scale is giving credit for a weighed item;***
- 14 ***(b) an item is pre-weighed on a legal for trade scale and marked with the correct net weight;***
- 15 ***(c) a device or system is generating labels for standard weight packages;***
- 16 ***(d) postal scales or weight classifiers are generating manifests for packages to be picked up at a later***
- 17 ***time; or***
- 18 ***(e) livestock and vehicle scale systems generate weight tickets to correct erroneous tickets.***

19

20 *Recorded **representations for** manual weight entries, except those on labels generated for packages of standard*
21 *weights, shall identify the weight value as a manual weight entry by one of the following terms: “Manual*
22 *Weight,” “Manual Wt,” or “MAN WT.” The use of a symbol to identify multiple manual weight entries on a*
23 *single document is permitted, provided that the symbol is defined on the same page on which the manual weight*
24 *entries appear and the definition of the symbol is automatically printed by the recording element as part of the*
25 *document.*

26 *[Nonretroactive as of January 1, 1993] [*Nonretroactive as of January 1, 2005] **[*Nonretroactive as of***
27 ***January 1, 20XX]***
28 *(Added 1992) (Amended 2004 **and 20XX**).*

29 **Previous Action:**
30 2023: New Item

31

32 **Original Justification:**
33 The instances in which manual weight entries are allowed are limited by UR.3.9. but there are no corresponding
34 limitations in S.1.12. This addition will allow the evaluation of devices, software, or systems for compliance with
35 these limitations and provide manufacturers specific requirements to comply with when designing a commercial
36 device.

37 The submitter acknowledges that this is a complicated requirement to incorporate into the design of a device or system
38 and some may argue that it should remain a user requirement.

39

40 **Requested Status by Submitter:** Voting Item

1 **Comments in Favor:**

2 **Regulatory:**

- 3 •

4 **Industry:**

- 5 •

6 **Advisory:**

- 7 •

8 **Comments Against:**

9 **Regulatory:**

- 10 •

11 **Industry:**

- 12 •

13 **Advisory:**

- 14 •

15 **Neutral Comments:**

16 **Regulatory:**

- 17 •

18 **Industry:**

- 19 •

20 **Advisory:**

- 21 •

22 **Item Development:**

23 New

24 Additional letters, presentation and data may have been submitted for consideration with this item. Please refer to
25 <https://www.ncwm.com/publication-15> to review these documents.

SCL-23.1	
Regional recommendation to NCWM on item status:	
<input type="checkbox"/> Recommend as a Voting Item on the NCWM agenda <input type="checkbox"/> Recommend as an Information Item on the NCWM agenda <input type="checkbox"/> Recommend as an Assigned Item on the NCWM agenda <i>(To be developed by an NCWM Task Group or Subcommittee)</i> <input checked="" type="checkbox"/> Recommend as a Developing Item on the NCWM agenda <i>(To be developed by source of the proposal)</i> <input type="checkbox"/> Recommend Withdrawal of the Item from the NCWM agenda <i>(In the case of new proposals, do not forward this item to NCWM)</i> <input type="checkbox"/> No recommendation from the region to NCWM <i>(If this is a new proposal, it will not be forwarded to the national committee by this region)</i>	
Comments and justification for the regional recommendation to NCWM: (This will appear in NCWM reports)	
No comments were received on this item during the 2022 SWMA Annual Meeting.	
The SWMA S&T Committee recommends this item move forward as a Developing Item.	

1

2 **SCL-23.2** **Table S.6.3.a. Marking Requirements, and Table S.6.3.b. Notes for Table**
 3 **S.6.3.a. Marking Requirements**

4 **Source:**
 5 NTEP Weighing Sector

6 **Purpose:**
 7 Add an additional marking requirement for single draft weigh-in-motion vehicle scale to include a vehicle type
 8 restriction.

9 **Item under Consideration:**

Table S.6.3.a.					
Marking Requirements					
To Be Marked With ↓	Weighing Equipment				
	Weighing, Load-Receiving, and Indicating Element in Same Housing or Covered on the Same CC1	Indicating Element not Permanently Attached to Weighing and Load-Receiving Element or Covered by a Separate CC	Weighing and Load-Receiving Element Not Permanently Attached to Indicating Element or Covered by a Separate CC	Load Cell with CC (11)	Other Equipment or Device (10)
<u>Vehicle Type Restriction (28)</u>			X		

10

1 And

2 **Table S.6.3.b.**

3 **Notes for Table S.6.3.a. Marking Requirements**

4
5 **28. Weigh-in-Motion vehicle scales must be marked with a vehicle type restriction, if applicable, which**
6 **shall be readily apparent when viewing the reading face of the scale indicator.**
7 **(Added 20XX)**

8 **Previous Action:**

9 New item in 2023

10 **Original Justification:**

11 As discussed at the NTEP Weighing Sector Meeting, multiple vehicle types are tested during the NTEP publication
12 14 test. If a specific vehicle type is failed or not tested, there needs to be a restriction on the vehicle types passed on
13 the certificate. This restriction must also be marked on the device.

14 The Sector requested that this be a Voting item in 2023.

15 **Comments in Favor:**

16 **Regulatory:**

- 17
 -

18 **Industry:**

- 19
 -

20 **Advisory:**

- 21
 -

22 **Comments Against:**

23 **Regulatory:**

- 24
 -

25 **Industry:**

- 26
 -

27 **Advisory:**

- 28
 -

29 **Neutral Comments:**

30 **Regulatory:**

- 31
 -

32 **Industry:**

- 33
 -

34 **Advisory:**

- 35
 -

36 **Item Development:**

- 1 New
- 2 Additional letters, presentation and data may have been submitted for consideration with this item. Please refer to
- 3 www.ncwm.com/publication-15 to review these documents.

SCL-23.2
<p>Regional recommendation to NCWM on item status:</p> <ul style="list-style-type: none"> <input type="checkbox"/> Recommend as a Voting Item on the NCWM agenda <input type="checkbox"/> Recommend as an Information Item on the NCWM agenda <input type="checkbox"/> Recommend as an Assigned Item on the NCWM agenda <i>(To be developed by an NCWM Task Group or Subcommittee)</i> <input checked="" type="checkbox"/> Recommend as a Developing Item on the NCWM agenda <i>(To be developed by source of the proposal)</i> <input type="checkbox"/> Recommend Withdrawal of the Item from the NCWM agenda <i>(In the case of new proposals, do not forward this item to NCWM)</i> <input type="checkbox"/> No recommendation from the region to NCWM <i>(If this is a new proposal, it will not be forwarded to the national committee by this region)</i>
<p>Comments and justification for the regional recommendation to NCWM: <i>(This will appear in NCWM reports)</i></p> <p>No comments were received on this item during the 2022 SWMA Annual Meeting.</p> <p>The SWMA S&T Committee recommends this item move forward as a Developing Item.</p>

- 4
- 5 **SCL-22.2 A UR.1. Selection Requirements, UR.1.X. Cannabis**

6 **Source:**
7 NCWM Cannabis Task Group

8 **Purpose:**
9 Establish uniform scale suitability requirements among the states for sales of cannabis.

10 **Item Under Consideration:**
11 Amend Handbook 44, Scales Code as follows:

12 **UR.1. Selection Requirements.** Equipment shall be suitable for the service in which it is used with respect to
13 elements of its design, including but not limited to, its capacity, number of scale divisions, value of the scale
14 division or verification scale division, minimum capacity, and computing capability.⁴

15 ...

16 **UR.1.X. Cannabis. – The scale division for scales weighing Cannabis shall not exceed:**

- 17 (a) **0.01g for net weighments up to capacity,**
- 18 (b) **0.1g for net weighments greater than 10g, up to capacity, and**
- 19 (c) **1g for net weighments greater than 100g, up to capacity.**
- 20 **(Added 20XX)**

21 **Previous Action:**
22 2022: Assigned to the Cannabis Task Group.

1 **Original Justification:**

2 As states legalize sales of cannabis in its various forms, the need has arisen for uniform standards for scale suitability.
3 Uniform requirements from one state to the next, will strengthen each jurisdiction's ability to effectively regulate the
4 industry in a fair and equitable manner. Uniform standards also provide industry with expectations regardless of the
5 jurisdiction, reducing potential conflict or confusion.

6 Some states may already have scale suitability requirements differing for those proposed here. The task group is
7 hopeful that differences can be resolved so that the standards are the same in every jurisdiction:

8 The proposed suitability requirements are based on existing standards as set forth by the California Division of
9 Standards, Division of Measurement Standards.

10 The submitter requested that this item be a Developing Item.

11 **Comments in Favor:**

12 **Regulatory:**

13 • 2022 Interim: Several regulatory officials voiced support of continuing to develop this item. The State
14 of Kansas noted that HB44 scale code Table 8 contains "recommended" minimum loads and cannot be
15 used for enforcement. A suggestion was made to use e verification interval (instead of d) for the code
16 application.

17 **Industry:**

18 • 2022 Interim: The Scale Manufacturers Association supports developing the item and recommended
19 aligning the item with HB44 Table 8, Recommended Minimum Load.

20 **Advisory:**

21 •

22 **Comments Against:**

23 **Regulatory:**

24 •

25 **Industry:**

26 • 2022 Interim: The Committee heard comments from industry members that do not support this item.
27 An industry member indicated that this proposal is an unprecedented requirement for devices for a
28 specific industry. A&D noted that if the item progresses, they would suggest a minimum scale
29 division of 0.01 g for weighments up to 100 g.

30 **Advisory:**

31 • 2022 Interim: NIST OWM reiterated their written analysis of this item and recommends it being
32 considered as a guidance document only. The full analysis can be found on the NCWM website.

33 **Neutral Comments:**

34 **Regulatory:**

35 • 2022 Interim: Some regulators voiced concern that this item should apply not only to cannabis but to
36 all commodities that are of high cost.

37 **Industry:**

38 •

1 **Advisory:**

- 2 •

3 **Item Development:**

4 NCWM 2022 Interim Meeting: After hearing comments from the floor and referencing submitted supporting
 5 documents, the Committee has assigned this item back to the NCWM Cannabis Task Group for further development.
 6 The Task Group should consider the several proposals for alternate language that were provided by the regional
 7 associations. For more information or to provide comment, please contact:

8 Vice Wolpert
 9 NCWM Cannabis Task Group
 10 vwolpert@azda.gov

 Charles Rutherford
 NCWM Cannabis Task Group
charlie@cprsqaredinc.com

11 NCWM 2022 Annual Meeting: The Committee was given an update from Mr. Charles Rutherford, NCWM Cannabis
 12 Task Group Co-Chair. In his update, Mr. Rutherford requested that this item remain Assigned to the Task Group for
 13 further discussion. The Scales Focus Group will be regrouping, with Mr. Lou Sakin (Hopkinton, MA) as the Chair,
 14 for further development of the item. The Committee has agreed that this item will retain an Assigned status.

15 **Regional Associations' Comments:**

16 WWMA 2021 Annual Meeting: Josh Nelson (Ex-Officio NCWM S&T Committee) : put forward to address some
 17 issues for cannabis, recommend developing - still needs work and continue to work forward. Matt Douglas (California
 18 - DMS) : California supports further development, add non retroactive date - subsection A states up to capacity... lists
 19 suitability requirements based on California, however, this info is not a standard. Eric Golden (Cardinal Scales) :
 20 section A B and C, be better to say 0.1 g for net weighments up to 10 grams, then B 10 to 100 grams, then C say over
 21 100, etc. Kurt Floren (LA County) : Mr. Golden stated perfectly what is lacking. There has to be ranges put in as to
 22 where the graduations are appropriate. Erin Sullivan (CO Department of Agriculture) : does this pertain to cannabis
 23 in any form or concentration? Josh Nelson (Ex-Officio NCWM S&T Committee) : this is what is going into HB44 -
 24 each jurisdiction has to define their own. For Oregon, medical is much different than retail. Retail has to abide by this.
 25 Med. Does not. Verbiage in A B and C does need additions. Erin Sullivan (CO Department of Agriculture) : grows
 26 vs. dispensaries? Different products in processing facilities are weighed with many containers on the scales. Do states
 27 determine the regulation? Josh Nelson (Ex-Officio NCWM S&T Committee) : up to the states to determine how to
 28 apply tares and increments in which product is weighed. Kurt Floren (LA County): cannabis products: later we'll see
 29 proposed def. of cannabis and cannabis products, are we anticipating the adoption of the proposed language? Josh
 30 Nelson (Ex-Officio NCWM S&T Committee) : it is not limited to flowers or bud. Mentions dabs. Is there a packaging
 31 requirement for the label? Oregon does. There must be a legal for trade scale that can prove they are meeting net
 32 contents. They must ensure that their process is being executed correctly. He thinks this is not limited to flower/bud.
 33 Kurt Floren (LA County): this raises the point that further consideration needs to be put into terms. Brownies, cannabis
 34 infused pizza.. And other items sold by weight. Are we setting the terms for pure cannabis product or are the scales
 35 being used for any cannabis containing product? Josh Nelson (Ex-Officio NCWM S&T Committee) : welcomes
 36 written input for this topic from anyone. Josh will continue to develop this. Eric Golden (Cardinal Scales) : clarification
 37 on Mr. Nelson: geared towards net sales, packaging for the customer. Is this part of the track and trace program for
 38 growers or just for retail? Josh Nelson (Ex-Officio NCWM S&T Committee) : needs to be expanded upon, in Oregon:
 39 even the growers have to do track and trace. Any scale weight that is used for the cannabis tracking system needs to
 40 be Weights and Measures compliant. Maybe has to address even a class III scale. They will look more into it. Joe
 41 Moreo (Ag. Com. Sealer) : over time we are going to need one level for concentrates, one for food, one for flower,
 42 one size fits all will not work. Josh Nelson (Ex-Officio NCWM S&T Committee) : Agrees that one size does not fit
 43 all. This will start to give limitations as to what a particular weight will be. Not trying to pigeon hole any device into
 44 one category, just trying to figure out what works, that's the intent.

45 The WWMA S&T Committee recommends the item be assigned a developmental status so that the submitter can
 46 continue to work on this as they commented during open hearings.

1 SWMA 2021 Annual Meeting: Russ Vires, SMA, stated that they have no position on this item at this time. Matt
2 Curran, State of Florida, stated that he supports this as a Voting item. He also provided comments in support of this
3 item from Eric Golden, Cardinal Scale. Cardinal offered some changes as well. The suggested changes are as follows:

4 **UR.1.X. Cannabis. – The scale division for scales weighing Cannabis shall not exceed:**

- 5
6 (a) **0.01g for net weightments ~~up to capacity~~ up to 10g.**
7 (b) **0.1g for net weightments greater than 10g, up to 100g, ~~capacity, and~~**
8 (c) **1g for net weightments greater than 100g, up to capacity.**
9 **(Added 20XX)**

10 Charlie Rutherford, Cannabis Committee, stated that he supports this item moving forward as a voting item with the
11 changes suggested by Cardinal Scale and Dr. Curran.

12 This committee recommends that this item be moved forward as a Voting item if the changes suggested above are
13 made.

14 CWMA 2022 Annual Meeting: Doug Musick – KS – Welcomed the attempt to define suitability; Recommended the
15 following:

16 *SCL-22.2 UR.1. Selection Requirements, UR.1.X. Cannabis*

17 *UR.1.X. Cannabis. – A retail Cannabis scale shall not be used to weigh net loads smaller than 100 displayed scale*
18 *divisions “d”,*

19 *(a) 0.01g for net weightments 10g or less,*

20 *(b) 0.1g for net weightments greater than 10g and up to 100g, and*

21 *(c) 1g for net weightments greater than 100g.*

22 *(Added 20XX)*

23 Russ Vires – SMA – The addition of a User Requirement is not the best approach in this situation; User
24 Requirements do not typically apply to a specific commodity. Supports continuing as developing and the following
25 proposed changes should be considered instead:

26 - *The words “retail cannabis” should be added to the “Class II” section of Table 7a.*

27 - *The words “bulk cannabis processing and sales” should be added to the “Class III”*

28 *section of Table 7a.*

29 Charlie Stutesman – KS – Questions why only metric units are referenced and not also include inch-pound units.

30 The CWMA S&T Committee recommends this item remain with the NCWM Cannabis Task Group and that the
31 suggested changes are considered.

32 NEWMA 2022 Annual Meeting: Mr. James Cassidy (MA) commented as the Co-Chair of the NCWM Cannabis Task
33 Group. He supports the assigned status so the task group can continue to develop the item from comments received
34 at the 2022 Interim. Mr. Russ Vires (SMA) supports continued development and indicated that a user requirement
35 typically does not pertain to a specific commodity. Mr. Vires suggested the words “retail cannabis” should be added
36 to the “Class II” section of Table 7a and the words “bulk cannabis processing and sales” should be added to the “Class
37 III” section of Table 7a. Ms. Tina Butcher (NIST OWM) read the following statement: “As a non-regulatory
38 metrology institute, NIST defers to federal agencies with regulatory authority under the Controlled Substances Act
39 (CSA) for the scheduling of drugs or other substances. NIST does not have a policy role related to the production,
40 sale, distribution, or use of cannabis (including hemp and marijuana). While the 2018 Farm Bill removed hemp from
41 the list of controlled substances under Schedule I of the CSA, marijuana remains on that list. NIST must respect that
42 distinction even as it exercises its statutory authority to develop and disseminate national weights and measures
43 standards for the production, distribution, and sale of products in the commercial marketplace. NIST remains
44 committed to providing technical assistance to the weights and measures community. OWM has provided key
45 technical points for the community to consider in its deliberations of cannabis-related proposals, and OWM would be
46 happy to provide any necessary clarification. OWM comments are intended to encourage technically sound application
47 of legal metrology laws, regulations, and practices to the measurement and sale of these products.”

48 After hearing comments from the floor, the committee recognized the need for further development of the item and
49 recommended that the item retain an assigned status. The committee recommends the NCWM Cannabis Task Group
50 work with the SMA and other stakeholders to further develop this item.

1 Additional letters, presentation and data may have been submitted for consideration with this item. Please refer to
 2 www.ncwm.com/publication-15 to review these documents.

SCL-22.2
<p>Regional recommendation to NCWM on item status:</p> <p> <input type="checkbox"/> Recommend as a Voting Item on the NCWM agenda <input type="checkbox"/> Recommend as an Information Item on the NCWM agenda <input checked="" type="checkbox"/> Recommend as an Assigned Item on the NCWM agenda <i>(To be developed by an NCWM Task Group or Subcommittee)</i> <input type="checkbox"/> Recommend as a Developing Item on the NCWM agenda <i>(To be developed by source of the proposal)</i> <input type="checkbox"/> Recommend Withdrawal of the Item from the NCWM agenda <i>(In the case of new proposals, do not forward this item to NCWM)</i> <input type="checkbox"/> No recommendation from the region to NCWM <i>(If this is a new proposal, it will not be forwarded to the national committee by this region)</i> </p>
<p>Comments and justification for the regional recommendation to NCWM: <i>(This will appear in NCWM reports)</i></p> <p>The following comments were received during the 2022 SWMA Annual Meeting:</p> <p>Mr. Charlie Rutherford, Cannabis Task Group, stated that Table 1A has been updated in the item.</p> <p>The SWMA S&T Committee recommends this item remain as an Assigned Item.</p>

3

4 **WIM – WEIGH-IN-MOTION SYSTEMS – TENTATIVE CODE**

5 **WIM-23.1 Remove Tentative Status and Amend Numerous Sections Throughout**

6 **Source:**
 7 New York City DOT, C2SMART, Kistler, and Maryland DOT

8 **Purpose:**
 9 Provide a legal document that can be used by local and State agencies to certify Weigh-In-Motion (WIM) systems
 10 used for automated weight enforcement.

11 **Item under Consideration:**
 12 Amend Handbook 44 Weigh-In-Motions Systems Code as follows:

13 **Table of Contents**

14 **Weigh-In-Motions Systems Used for Vehicle Enforcement—~~Tentative Code~~**

15 ...

16 T.2. Tolerance Values for Accuracy ~~Class A~~-Class E. 172

17 ...

18 Additional letters, presentation and data may have been submitted for consideration with this item. Please refer to
 19 www.ncwm.com/publication-15 to review these documents.

1 **Section 2.25. Weigh-In-Motion Systems**
2 **Used for Vehicle Enforcement Screening — Tentative Code**

3 ~~This tentative code has a trial or experimental status and is not intended to be enforced. The requirements are~~
4 ~~designed for study prior to the development and adoption of a final code. Officials wanting to conduct an~~
5 ~~official examination of a device or system are advised to see paragraph G A.3. Special and Unclassified~~
6 ~~Equipment.~~

7 **A. Application**

8 **A.1. General.** – This code applies to systems used to weigh vehicles, while in motion, for the purpose of **screening**
9 ~~and sorting the vehicles based on the vehicle weight to determine if a static weighment is necessary~~
10 ~~enforcing the weight limit of road vehicles.~~

11 **A.2. Exception.** – This code does not apply to weighing systems intended for the collection of statistical traffic
12 data.

13 **A.3. Additional Code Requirements.** – In addition to the requirements of this code, weigh-in-motion **screening**
14 systems shall meet the requirements of Section 1.10. General Code.

15 ...

16 **S.1.3. Maximum Value of Division.** – The value of the system division “d” for a ~~Class A~~ Class E, weight-
17 in-motion system shall not be greater than 50 kg (100 lb).

18 ...

19 **S.1.6. Identification of a Fault.** – Fault conditions shall be presented to the operator in a clear and
20 unambiguous means. The following fault conditions shall be identified:

- 21 (a) Vehicle speed is below the minimum or above the maximum speed as specified.
- 22 ~~(b) The maximum number of vehicle axles as specified has been exceeded.~~
- 23 (b) A change in vehicle speed greater than that specified has been detected.
- 24 (c) Imbalanced weights between the left and right wheels have exceeded the specified values.
- 25 (d) The vehicle changes the lanes in the proximity of the sensor locations.

26 **S.1.7. Recorded Representations.**

27 **S.1.7.1. Values to be Recorded.** – At a minimum, the following values shall be printed and/or stored
28 electronically for each vehicle weighment:

29 transaction identification number;

30 **Station ID;**

31 lane identification (required if more than one lane at the site has the ability to weigh a vehicle in motion);

32 vehicle speed;

33 number of axles;

1 weight of each axle;
 2 **weight of each axle group;**
 3 identification and weight of axle groups;
 4 axle spacing;
 5 total vehicle weight;
 6 **total vehicle length;**
 7 all fault conditions that occurred during the weighing of the vehicle;
 8 violations, as identified in paragraph S.2.1. Violation Parameters, which occurred during the weighing
 9 of the vehicle; and
 10 time and date.

11 ...

12 **S.1.8. Value of the Indicated and Recorded System Division.** – The value of the system’s division “(d),”
 13 as recorded, shall be the same as the division value indicated.

14 **S.2. System Design Requirements.**

15 ...

16 **S.4.1. Designation of Accuracy.** – Weigh-in-motion systems meeting the requirements of this code shall
 17 be designated as accuracy ~~Class A~~ **Class E.**

18 ...

19 **N.1.1. Selection of Test Vehicles.** – All dynamic testing associated with the procedures described in each
 20 of the subparagraphs of N.1.5 shall be performed with a minimum of ~~two~~ **three** test vehicles.

21 The first test vehicle may be a two-axle, six-tire, single-unit truck **or FHWA Class 5;** that is, a vehicle with two
 22 axles with the rear axle having dual wheels. ~~The vehicle shall have a maximum gross vehicle weight of 10000~~
 23 ~~lb.~~

24 The second test vehicle shall be a five-axle, single-trailer truck **or FHWA Class 9 3S2 Type** ~~with a maximum~~
 25 ~~gross vehicle weight of 80000 lb.~~

26 **The third test vehicle shall be a three-axle, single-unit truck or FHWA Class 6.**

27 ...

28 ~~N.1.2.1. Static Test Loads. All static test loads shall use certified test weights.~~

29 **N.1.2.1. Dynamic Test Loads.** – Test vehicles used for dynamic testing shall be loaded **in three (3) different**
 30 **load conditions, to 85 % to 95 % of their legal maximum Gross Vehicle Weight.** The “load” shall be non-
 31 shifting and shall be positioned to present as close as possible, an equal side-to-side load.

32 **(a) an empty load condition,**

1 **(b) a fully loaded condition (>90% of the scale capacity or >90% of the maximum capacity of the**
2 **vehicle, whichever is less), and**

3 **(c) a half loaded condition approximately between the empty and fully loaded condition.**

4 **N.1.3. Reference Scale.** – Each reference vehicle **for dynamic test** shall be weighed statically **either** on a
5 multiple platform vehicle scale **or a single platform vehicle scale.**

6 **N.1.3.1. Multiple Platform Vehicle Scale – It** comprised of three individual weighing/load-receiving
7 elements, each an independent scale. The three individual weighing/load receiving elements shall be of such
8 dimension and spacing to facilitate:

9 **(a)** the single-draft weighing of all reference test vehicles;

10 **(b)** the simultaneous weighing of each single axle and axle group of the reference test vehicles on different
11 individual elements of the scale; and

12 **(c)** gross vehicle weight determined by summing the values of the different reference axle and reference
13 axle groups of a test vehicle.

14 **N.1.3.2. Single Platform Vehicle Scale – Each individual axle or axle group of the reference test vehicles**
15 **shall be measured on the single platform vehicle scale. Only the single axle or axle group for**
16 **measurement shall be on the single platform while other single axles or axle groups shall be off the**
17 **platform. The GVW shall be determined by summing all the single axles and axle groups.**

18 The scale shall be tested immediately prior to using it to establish reference test loads and in no case more
19 than 24 hours prior. To qualify for use as a suitable reference scale, it must meet NIST Handbook 44,
20 Class III L maintenance tolerances.

21 **N.1.3.3. Location of a Reference Scale.** – The location of the reference scale must be considered since
22 vehicle weights will change due to fuel consumption.

23 **N.1.4. Test Speeds.** – All dynamic tests shall be **conducted at three speeds within 20 % below or at the**
24 **posted speed limit.**

25 **N.1.4.1. High Speed – maximum posted speed limit.**

26 **N.1.4.1. Low Speed – less than 10 mph.**

27 **N.1.4.1. Operation Speed – average between N.1.4.1. High Speed and N.1.4.2. Low Speed**

28 **N.1.5. Test Procedures.**

29 **N.1.5.1. Dynamic Load Test.** – The dynamic test shall be conducted using the test vehicles defined in N.1.1.
30 Selection of Test Vehicles. The test shall consist of a minimum of 20 runs for each test vehicle at ~~the~~ **each**
31 speed as stated in N.1.4. Test Speeds.

32 At the conclusion of the dynamic test, there will be a minimum of ~~20~~ **60** weight readings for each single axle,
33 axle group, and gross vehicle weight of the test vehicle. The tolerance for each weight reading shall be based
34 on the percentage values specified in Table T.2.2 Tolerances for Accuracy ~~Class A~~ **Class E.**

35 ...

36 **T.2. Tolerance Values for Accuracy ~~Class A~~ Class E.**

37 **T.2.1. Tests Involving Digital Indications or Representations.** – To the tolerances that would otherwise
38 be applied in paragraphs T.2.2. Tolerance Value for Dynamic Load Test and T.2.3. Tolerance Value for

1 Vehicle Position Test, there shall be added an amount equal to one-half the value of the scale division to
 2 account for the uncertainty of digital rounding.

3 **T.2.2. Tolerance Values for Dynamic Load Test.** – The tolerance values applicable during dynamic load
 4 testing are as specified in Table T.2.2 **for enforcement purposes.**

Table T.2.2. Tolerances for Accuracy Class A	
Load Description*	Tolerance as a Percentage of Applied Test Load
Axle Load	± 20 %
Axle Group Load	± 15 %
Gross Vehicle Weight	± 10 %
* No more than 5 % of the weighments in each of the load description subgroups shown in this table shall exceed the applicable tolerance.	

5

Table T.2.2. Tolerances for Accuracy Class E	
Load Description*	Tolerance as a Percentage of Applied Test Load
Axle Load	± 15 %
Axle Group Load	± 10 %
Gross Vehicle Weight	± 6 %
* No more than 5 % of the weighments in each of the load description subgroups shown in this table shall exceed the applicable tolerance. The GVW tolerance shall be ± 10 % for all weighments (100% compliance).	

6

7 ...

8 **T.4. Radio Frequency Interference (RFI) and Other Electromagnetic Interference Susceptibility.** – The
 9 difference between the weight indication due to the disturbance and the weight indication without the disturbance
 10 shall not exceed the tolerance value as stated in Table T.2.2 Tolerances for Accuracy ~~Class A~~ **Class E.**

11 **UR. User Requirements**

12 **UR.1. Selection Requirements.** – Equipment shall be suitable for the service in which it is used with
 13 respect to elements of its design, including but not limited to, its capacity, number of scale divisions, value of the
 14 scale division, or verification scale division and minimum capacity.

15 **UR.1.1. General.** – The typical class or type of device for particular weighing applications is shown in
 16 Table 1. Typical Class or Type of Device for Weighing Applications.

Table 1. Typical Class or Type of Device for Weighing Applications	
Class	Weighing Application
A	Screening and sorting of vehicles based on axle, axle group, and gross vehicle weight.
E	<u>Enforcing of vehicles based on axle, axle group, and gross vehicle weight</u>
Note: A WIM system with a higher accuracy class than that specified as “typical” may be used.	

1

2 **Previous Action:**
3 New item in 2023

4 **Original Justification:**
5 **1. INTRODUCTION**

6 The Brooklyn-Queens Expressway (BQE) is an aging and deteriorating 6-lane highway which comprises a critical
7 link of I-278 - the sole Interstate highway in Brooklyn, connecting it to Manhattan, Staten Island, and Queens in New
8 York. Constructed in 1954 and comprised of varying and complex structure types, the segment of the BQE between
9 Atlantic Ave. Interchange to the South and Sands St. to the North is nearing the end of its design life. Urgent repairs
10 are underway, while roughly 110 spans may be in need of intervention by 2028, and another 75 spans may be in need
11 of intervention within the next decade. Weigh in Motion (WIM) sensors, installed in October 2019, have revealed
12 overweight vehicles, excessively exceeding FHWA legal load limits, with gross vehicle weights (GVW) that range
13 from just over 80,000 lbs to as high as 200,000. The continued presence of overweight vehicles on the BQE
14 contributes to the continued structural deterioration of this aging piece of infrastructure. The New York State
15 legislature recently authorized the New York City Department of Transportation to conduct automated overweight
16 vehicle enforcement through a WIM demonstration program; however, a universal standard has not yet been
17 established that specifically defines a protocol for calibration and certification by the New York State local Division
18 of Weights and Measures.

19 In response to this challenge, this proposal seeks an amendment of Section 2.25 of NIST Handbook 44 to allow for
20 Weigh-In-Motion Systems Used for Automated Vehicle Weight Enforcement. The remainder of this proposal lays
21 out the justification for the amendment, using the BQE as an example to establish the urgent need for the amendment,
22 supported by data received from other State programs, including New Jersey, Maryland, and Indiana. The City of
23 New York is not alone in its struggle to maintain the safety and the structural integrity of its infrastructure. Guarding
24 against violations of vehicle weight restrictions that are enacted to protect critical infrastructure is an issue of national
25 concern.

26 The combined interstate data presented here stresses the national importance of establishing protocols for automated
27 vehicle weight enforcement using WIM, citing:

- 28 • the deleterious effects of overweight vehicles and axles on primary structural components and pavements;
- 29 • the difficulty associated with the use of screening combined with stationary weighing stations to enforce
30 vehicle weight regulations;
- 31 • the percentages of overweight vehicles on major interstates across the nation; and
- 32 • the proven accuracy of WIM equipment used in several states across the nation.

33
34 **2. THE BROOKLYN-QUEENS EXPRESSWAY: THE NEED FOR URGENT INTERVENTION**

35 Constructed in 1954, the BQE is a network of varying and complex structure types, including multi-girder steel
36 bridges, concrete arch bridges, and double and triple concrete cantilever structures. The triple-cantilever section
37 possesses unusual engineering characteristics. Its three levels of cantilevered structure (comprised of two levels of

vehicular roadway and a top-level pedestrian Brooklyn Heights Promenade) are supported by a vertical wall that also serves to hold back the earth, and, in turn, the neighborhood of Brooklyn Heights behind it. Thus, there is a complex system of forces acting to hold up the cantilevered decks and soil, and moving one of its parts affects the others. With major structural components nearly 70 years old, this segment of the BQE is rapidly approaching the end of its design life. Due to its complex nature and its historic integration with the surrounding communities, repair and replacement of this segment of the BQE requires careful and strategic planning, exhausting every avenue to maintain the safety of its operations and the integrity of its structural condition.

Its aging characteristics are evidenced by a number of factors, including:

- Visible signs of deterioration, including scaling, efflorescence, transverse cracking, map cracking, and spalling, with exposed and corroded rebar at the underdeck, walls, and substructure components;
- Poor freeze-thaw results in the concrete cores;
- High chloride levels in the deck, leading to the onset and propagation of steel rebar corrosion in the structural decks and substructure components;
- Deteriorated concrete beneath the surface, as detected by Non-Destructive Test and Evaluations (NDT/E) and verified by probe samples; and
- Projected decreases in structural load ratings to below standard limits, with isolated segments projected to fall below standard limits by 2026, and large segments of this portion of the corridor projected to fall below standard limits by 2028.

Numerous traffic studies have been completed for this segment of the corridor, revealing average daily traffic (ADT) of approximately 153,000 vehicles, including a substantial average daily truck traffic (ADTT, up to 13 percent of the total ADT). In addition, the installation of WIM sensors in October 2019 has revealed that a considerable number of the vehicles traversing the BQE are classified as overweight, when compared with FHWA legal load limits. WIM data shows Gross Vehicle Weights ranging from just over 80,000 lbs to as high as 200,000 lbs, with roughly 20% of North-bound traffic classified as overweight, and roughly 8% of South-bound traffic classified as overweight.

The New York City Mayoral Executive Order 51, executed in January 2020, mandated the formation of the New York City Police Department (NYPD) BQE Truck Enforcement Task Force, whose purpose is to ensure that all existing weight restrictions on the BQE are strictly enforced. However, the lack of roadway shoulders on this stretch of the BQE means that there is insufficient space for the New York City Department of Transportation (NYCDOT) to introduce stationary weighing stations, or for NYPD enforcement officers to pull over overweight vehicles and use portable scales to screen and enforce legal weight limits.

Urgent repairs are currently underway for two spans within this complex network, while structural assessments show that roughly 110 spans may be in need of intervention by 2028, and roughly 75 spans may be in need of intervention within the next decade.

In response to this challenge, NYCDOT has initiated aggressive efforts to develop and implement a plan that maintains the operational safety of the BQE, as well as protects its structural integrity, including the pursuit of automated weight enforcement using WIM on this segment of corridor. It has combined its efforts with other local and State agencies in order to demonstrate that this is not an isolated local problem, but a national need.

3. AUTOMATED TRUCK ENFORCEMENT USING WIM: THE NATIONAL NEED

The national roadway infrastructure, including bridges and pavement, has handled substantial daily truck traffic. While trucks have been an integral part of the freight movement network in distributing goods and services to various communities, many trucks are often found to be overweight beyond the FHWA legal load limits. Illegally overweight vehicles have been shown to be one of the primary causes of the deterioration of aging pavement and bridges.

1 Accordingly, the infrastructure suffers from significant deterioration because of the existing environmental conditions
 2 exacerbated by the frequently increasing and substantial number of overweight vehicles.

3 Vehicles on Interstate highways must conform to the Federal Bridge Formula (FBF), designed to protect bridges from
 4 vehicle overloads beyond the legal limits. To date, the enforcement regulations have been executed at stationary
 5 weighing stations across the nation, especially at the borders between states. However, the stationary stations have
 6 limited resources for effective enforcement because: (1) the number of stationary weighing stations is not spatially
 7 well distributed across the nation; (2) the operation hours are limited; and (3) the number of enforcement officers is
 8 insufficient.

9 Though each state allows a certain number of permitted vehicles to exceed the FHWA weight limits on Interstate
 10 Highways, the number of permit overweight vehicles is typically a small fraction of the total. According to a previous
 11 study (Nassif et al., 2016)¹, the number of permit overweight vehicles is only 4% of the total overweight vehicles
 12 observed at NJ WIM stations. In New Jersey, it was also noticed that the overweight vehicles cited at the stationary
 13 weighing stations were only a small fraction (6.4%) of the *actual* overweight populations recorded by the WIM sensors
 14 on the main lanes, and this is, in turn, 0.142% of the total number of vehicles (Nassif et al., 2021)². In New York City,
 15 enforcement officers have been able to cite only 14.7% of the *actual* number of overweight vehicles on and near
 16 Interstate Highway I-278 between February and December of 2021. Therefore, the overweight enforcement practices
 17 at the stationary weighing stations, combined with using mobile enforcement units, are ineffective in substantially
 18 reducing the percentage of overweight vehicles.

19 The figure below summarizes the percent of overweight vehicles, relative to the ADTT for each US State. The overall
 20 overweight percentage out of ADTT is 13.2%, based on the data in the figure below.

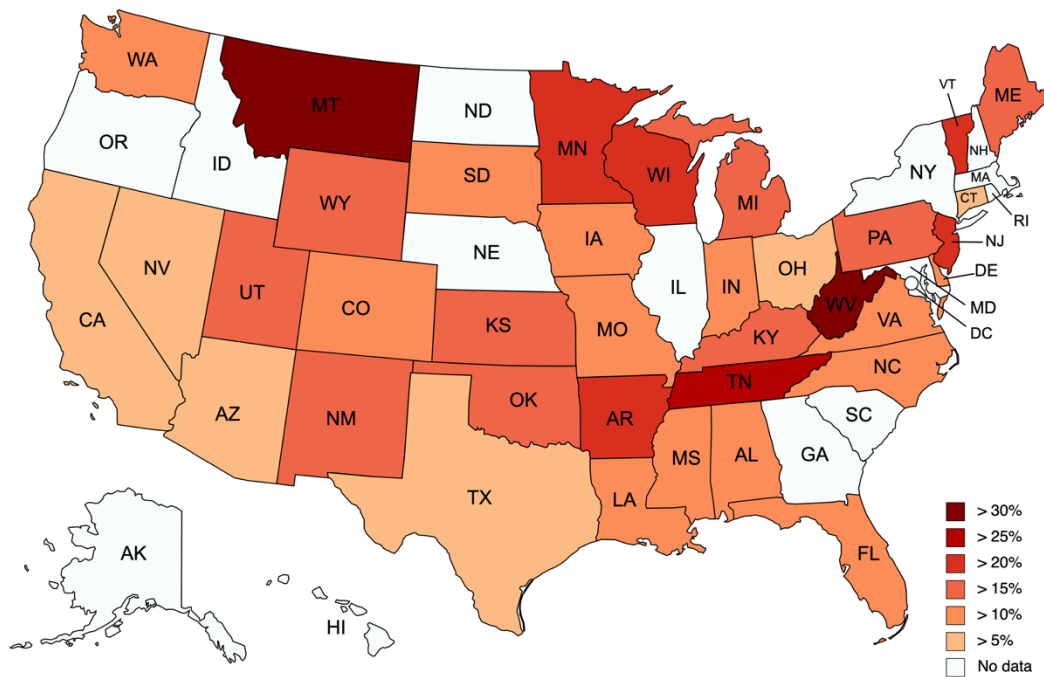

Figure 1. Overweight percentage per State

¹¹ Nassif, H., K. Ozbay, H. Wang, R. Noland, P. Lou, S. Demirogluk, D. Su, C.K. Na, J. Zhao, and M. Beltran. Impact of freight on highway infrastructure in New Jersey. Final Report FHWA-2016-004, NJDOT, 2016

² Nassif, H., K. Ozbay, C.K. Na, and P. Lou. Feasibility of Autonomous Enforcement using A-WIM system to Reduce Rehabilitation Cost of Infrastructure, C2SMART Tier 1 University Transportation Center, Year 3 Final Report, 2021

1 Going beyond weight enforcement, officers in most States are responsible for checking Commercial Motor Vehicles
2 (CMV's) for safety. This includes different levels of truck inspection, including the driver credentials, hours of
3 service, key systems on the truck, load securement, and many more. The highest level of inspection, Level 1, has 20+
4 safety criteria that an officer checks on a CMV. There is an opportunity with automated weight enforcement to, not
5 only deter overweight vehicles on the nation's infrastructure, but to automate the inspection tasks of officers, freeing
6 them up so they can do more inspections for other safety issues related to CMV's. Currently, with most sites running
7 with a single officer, as they are focused on weighing, doing an inspection, or interviewing a driver, other unsafe
8 vehicles behind the current one go by without scrutiny until an officer can complete their task.

9 **4. AUTOMATED TRUCK ENFORCEMENT USING WIM: PROVEN ACCURACY OF WIM** 10 **TECHNOLOGY**

11 ASTM E1318-09 Type III accuracy requirements have been used by many States in their fixed and virtual weigh
12 stations to screen CMV's for over a decade. In New York, three calibration tests were performed using various trucks
13 (Class 9, Class 7, Class 6, and Class 5), and it was found that the WIM system could provide 100% compliance for
14 GVW within 6%, single axle weight within 15%, tandem axle weight within 10%, and even wheel weight within 20%.
15 In Indiana, the Indiana DOT and Purdue University studied the accuracy of the virtual WIM sensors on the main lanes
16 compared to the stationary weighing station. They found that 98% of the virtual WIM weights were within 5% of the
17 static weights.

18 Attachment A includes data from New York, Indiana, and Maryland, proving the accuracy of their WIM technology.
19 Additionally, Wisconsin, and two other States have expressed interest in sharing data from their sites which meet these
20 accuracy requirements.

21 Given the consistent accuracy of WIM measurements, compared with measurements obtained from the stationary
22 scales, the amendment of Handbook 44 to expand its provisions for screening to include automated vehicle weight
23 enforcement using WIM is both prudent and justified.

24 **5. CONCLUSIONS**

25 Across the nation, the deterioration of aging infrastructure is exacerbated by the presence of overweight vehicles in
26 excess of the Federal Bridge Formula (FBF). Though several states have implemented vehicle weight enforcement
27 measures using a screening protocol that includes the use of mobile enforcement officers and stationary scales, these
28 measures have been insufficient in significantly reducing the volumes of overweight vehicles on the nation's
29 infrastructure. The use of WIM for the purposes of automated vehicle weight enforcement would both alleviate this
30 problem and free up local and state resources to address other safety concerns. However, to date, no unified national
31 standard specifically paves the way for the certification of WIM technology to be used for the purposes of automated
32 vehicle weight enforcement. The amendment of Section 2.25 of NIST Handbook 44 will provide such a standard.
33 With several states evidencing the proven accuracy of current WIM technology, the amendment of Section 2.25 to
34 expand its screening provisions to include automated vehicle weight enforcement using WIM is both prudent and
35 justified.

36 This request is not to introduce new regulations to the trucking industries but to guide the trucking industries to comply
37 with the applicable laws to protect our infrastructure, provide safe corridors to the nation's taxpayers, and improve the
38 resilience of our built environment. Moreover, this request would allow the United States to catch up with other
39 countries globally that have successfully implemented and proved automated weight enforcement, including China
40 (2004), the Czech Republic (2010), Russia (2013), Hungary (2016), France (in process) and Brazil (in process).

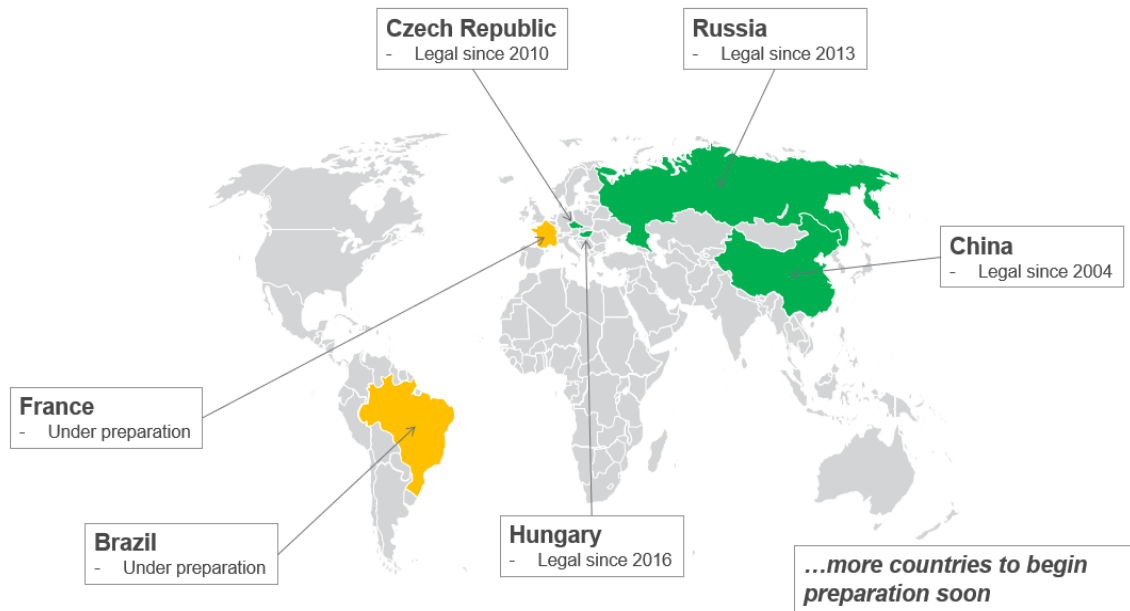

1 Figure 2. Automated enforcement around the world

2 The submitters requested that this be a Voting item in 2023/

3 **Comments in Favor:**

4 **Regulatory:**

- 5 •

6 **Industry:**

- 7 •

8 **Advisory:**

- 9 •

10 **Comments Against:**

11 **Regulatory:**

- 12 •

13 **Industry:**

- 14 •

15 **Advisory:**

- 16 •

17 **Neutral Comments:**

18 **Regulatory:**

- 19 •

- 1 **Industry:**
- 2 •
- 3 **Advisory:**
- 4 •

5 **Item Development:**

6 Additional letters, presentation and data may have been submitted for consideration with this item. Please refer to
 7 www.ncwm.com/publication-15 to review these documents

WIM-23.1
<p>Regional recommendation to NCWM on item status:</p> <ul style="list-style-type: none"> <input type="checkbox"/> Recommend as a Voting Item on the NCWM agenda <input type="checkbox"/> Recommend as an Information Item on the NCWM agenda <input type="checkbox"/> Recommend as an Assigned Item on the NCWM agenda <i>(To be developed by an NCWM Task Group or Subcommittee)</i> <input checked="" type="checkbox"/> Recommend as a Developing Item on the NCWM agenda <i>(To be developed by source of the proposal)</i> <input type="checkbox"/> Recommend Withdrawal of the Item from the NCWM agenda <i>(In the case of new proposals, do not forward this item to NCWM)</i> <input type="checkbox"/> No recommendation from the region to NCWM <i>(If this is a new proposal, it will not be forwarded to the national committee by this region)</i>
<p>Comments and justification for the regional recommendation to NCWM: <i>(This will appear in NCWM reports)</i></p> <p>The following comments were received during the 2022 SWMA Annual Meeting:</p> <p>Dr. Hanni Nasif of Rutgers University, the submitter of this item, presented. During the presentation he stated that the device currently operates within 6% of the Type III ASTM Standard. The submitter stated that their intentions is for direct enforcement fines to not apply within 10 % of weight limit based on local enforcement procedures.</p> <p>Mr. Peter Fedechko, International Road Dynamics, stated that he supports this item.</p> <p>Mr. Chesser, State of Arkansas, stated that he liked the language on page 167 lines 25-28. He asked why strike paragraph B. He also cited some errors on page 170.</p> <p>Mr. Paul Floyd, State of Louisiana, stated that he has concerns about the accuracy of this system. He stated that he would support this item for screening purposes and recommends it moving forward as developing.</p> <p>The SWMA S&T Committee asked about the speed and weight requirements used for testing in the proposal not matching with what the devices will be used to regulate. The committee also questioned whether these devices would receive a type evaluation from NTEP if specifications were added to the handbook. Additionally, the committee questioned whether a direct enforcement procedure should be separated from the tentative screening code.</p> <p>The SWMA S&T Committee recommends this item move forward as a Developing Item.</p>

8

1 **LMD – LIQUIDE MEASURING DEVICES**

2 **LMD-23.3 Automatic Temperature Compensation Task Group**

3 **Source:**

4 Michael Cleary, Retired State of California

5 **Purpose:**

6 Revisit implementing Temperature Compensation of motor fuel at retail.

7 **Item under Consideration:**

8 Form a task group to research the issue of Automatic Temperature Compensation for retail fuels.

9 **Previous Action:**

10 New item in 2023

11 **Original Justification:**

12 Given the skyrocketing price of gasoline and diesel fuel the Conference should study the impact on the American
13 consumer.

14 **Comments in Favor:**

15 **Regulatory:**

- 16 •

17 **Industry:**

- 18 •

19 **Advisory:**

- 20 •

21 **Comments Against:**

22 **Regulatory:**

- 23 •

24 **Industry:**

- 25 •

26 **Advisory:**

- 27 •

28 **Neutral Comments:**

29 **Regulatory:**

- 30 •

31 **Industry:**

- 32 •

33 **Advisory:**

- 34 •

1 **Item Development:**

2 New

3 Additional letters, presentation and data may have been submitted for consideration with this item. Please refer to
 4 www.ncwm.com/publication-15 to review these documents.

LMD-23.3
<p>Regional recommendation to NCWM on item status:</p> <ul style="list-style-type: none"> <input type="checkbox"/> Recommend as a Voting Item on the NCWM agenda <input type="checkbox"/> Recommend as an Information Item on the NCWM agenda <input type="checkbox"/> Recommend as an Assigned Item on the NCWM agenda <i>(To be developed by an NCWM Task Group or Subcommittee)</i> <input type="checkbox"/> Recommend as a Developing Item on the NCWM agenda <i>(To be developed by source of the proposal)</i> <input checked="" type="checkbox"/> Recommend Withdrawal of the Item from the NCWM agenda <i>(In the case of new proposals, do not forward this item to NCWM)</i> <input type="checkbox"/> No recommendation from the region to NCWM <i>(If this is a new proposal, it will not be forwarded to the national committee by this region)</i>
<p>Comments and justification for the regional recommendation to NCWM: <i>(This will appear in NCWM reports)</i></p> <p>The following comments were received during the 2022 SWMA Annual Meeting:</p> <p>Dr. Matt Curran, State of Florida, stated that the NCWM has seen proposals similar to this one in the past. He referenced a study from the California Energy Commission that determined the net cost difference observed before and after adding temperature compensation was very small. He also suggested that, if the item ends up being withdrawn, the submitter may consider sending it to FALS.</p> <p>Mr. Prentiss Searles, American Petroleum Institute, stated that he did not support this item, and recommend it be withdrawn.</p> <p>Mr. Chesser, State of Arkansas, agreed with Mr. Searles.</p> <p>Mr. Ramsburg, State of Maryland, opposes this item and recommends withdrawal.</p> <p>Mr. Tory Brewer, State of West Virginia, opposes this item.</p> <p>Mr. Stokes, State of South Carolina, recommends this item be withdrawn.</p> <p>Mr. Murnane, Seraphin, stated that he totally disagrees with this item and recommends its withdrawal.</p> <p>The SWMA S&T committee recommends this item be Withdrawn.</p>

5

6 **LMD-23.4 N.3.5. Wholesale Devices.**

7 **Source:**

8 American Petroleum Institute

9 **Purpose:**

10 Clarification that Small Volume Provers are included in N.3.5. Wholesale devices.

11 **Item under Consideration:**

1 Amend Handbook 44 Liquid Measuring Devices Code as follows:

2 **N.3.5. Wholesale Devices.** – The **total** delivered quantity **for any required accuracy test** should be
3 equal to, **or is recognized as being representative of, a volume equivalent to** at least the amount
4 delivered by the device in one minute at **its the meter’s** maximum discharge rate **and shall in no case**
5 **be less than 200 L (50 gal).**
6 (Amended 1987, ~~and~~ 1996, and 2023)

7 **Previous Action:**

8 New item in 2023

9 **Original Justification:**

10 The 1996 NCWM agreed that small volume provers (SVP) are suitable as a test standard. The 1996 changes included
11 modifications to paragraph N.3.5. to remove barriers for technology that could achieve the maximum flow rate of the
12 product flowing through the meter.

13 That said, portions of the text in paragraph N.3.5. have been interpreted to prohibit the use of an SVP because the
14 paragraph states, that the delivered quantity for the meter test (1) “should be equal to at least the amount delivered by
15 the device in one minute at its maximum discharge rate” and (2) “shall in no case be less than 200 L (50 gal).” Given
16 these criteria, an SVP could meet the first requirement, and may not meet the second requirement unless the base
17 prover volume was at least 200 L (50 gal). Research indicates that a reference to a 50 gallon minimum draft has been
18 in the Handbook since 1937. The size of wholesale meter deliveries when the 50 gal minimum was established in
19 paragraph N.3.5. is not reflective of the discharge rates of meters used today in commerce.

20 Therefore, modifications are warranted to paragraph N.3.5. to clarify that SVP’s that are properly sized for the test,
21 which can include having a base prover volume of less than 50 gallons, achieve the accuracy required to meet the
22 original design of N.3.5. The proposed additions clarify that the test device – whether SVP, neck-type prover, or
23 another type of test standard – must be capable of testing the maximum flowrate through the meter being tested. The
24 phrase “and shall in no case be less than 50 gal,” is deleted as SVPs with smaller volumes (e.g., 20-gallon base prover
25 volume) are capable of testing wholesale devices at flowrates exceeding 600 gallons per minute.

26 In 1996, the weights and measures community gathered data and published a report that recognized the suitability of
27 the SVP as a test standard for liquid measuring devices. Additionally, a 105 series (*Specifications and Tolerances for*
28 *Reference Standards and Field Standard Weights and Measures*) standard exists for Dynamic SVPs.

29 Over the last 25 years, SVP technology has improved significantly and API Manual of Petroleum Measurement
30 Standards (MPMS) Chapter 4.6, *Pulse Interpolation*, provides the appropriate standards that ensure the SVP achieves
31 the necessary measurement tolerances. API standards MPMS has 23 chapters with Chapter 4.2, Displacement Provers
32 covering SVPs. The 3rd Edition of the standard was published in 2003, and an Addendum was issued in 2015. The
33 committee responsible for Chapter 4.2 includes over subject matter experts that assess the data and consider updates
34 and revisions to the standard. The accepted technology of the SVP’s achieves an accuracy, at a 95 percent confidence
35 level, that the calculated based prover volume is within plus or minus 0.029% when three consecutive runs agree

1 within 0.02% of one another. In other words, there is only a 5% probability that the true prover base volume lies
 2 outside the range of plus or minus 0.029% of the calculated base volume.

3 The goals for the proposed modification to paragraph N.3.5 are to:

- 4 • Reinforce the 1996 goal to remove any test conditions that would prohibit or restrict the use of an SVP
 5 or other methodologies
- 6 • Establish fair test conditions within the OEM’s intended range of the meter’s operating conditions
- 7 • Specify the minimum test conditions based on the meter’s ratings and the key characteristics for the
 8 proving device to conduct a test that demonstrates the meter’s performance in a commercial application
- 9 • Encompass the concept of both the volumetric neck-type prover and small-volume prover (SVP) test or
 10 any other methodologies that may be developed in the future
- 11 • Eliminate any language that would circumvent or alter the proper use of testing devices or their results
- 12 • Provide guidance on test parameters which meet the Fundamental Considerations without the need for a
 13 laundry list of possible test methodologies and equipment. The decision of whether or not to accept a
 14 given type of test standard still rests with the Director as outlined in the Fundamental Considerations.

15
 16 In addition to the action taken on the proposed revision to N.3.5., NIST has suggested it may be helpful to review and
 17 provide updates or supplements to the NIST Examination Procedure Outline 25 for Loading Rack Meters and possibly
 18 suggest modifications to NIST 105-7, “Specifications and Tolerances for Reference Standards and Field Standard
 19 Weights and Measures: Specifications and Tolerances for Dynamic Small Volume Provers,” 1997, to provide
 20 additional guidance on properly sizing and selecting a suitable size small volume prover for a given metering
 21 system. Such guidance would require input from SVP manufacturers as well as regulators.

22 Some may oppose the removal of the 50-gallon test draft. However, research indicates that a reference to a 50 gallon
 23 minimum draft has been in the Handbook since 1937. The size of wholesale meter deliveries when the 50 gal
 24 minimum was established in paragraph N.3.5. is not reflective of the discharge rates of meters used today in commerce.

25 **Links to NIST OWM** newsletter articles written by Diane Lee on SVPs used in testing commercial measuring
 26 systems: [Weights and Measures Newsletter Archives - Field Standards | NIST](#)

- 27 H-003 Part 1 (2005)
- 28 H-004 Part 2
- 29 H-007 Part 3
- 30 H-010 Part 4
- 31 H-012 Part 5

32 Background Q&A:

- 33 1. Can you explain how uncertainty calculations differ between SVP vs can provers?
 - 34 • Tank provers provide a cubic inch uncertainty per 1,000 gallon prover by comparing the volume in the tank
 35 vs the volume of the computer.
 - 36 • SVPs provide a meter factor that is a ratio of the prover vs the meter for a period between detector
 37 switches. In addition, calibrations are performed multiple times and a statistical uncertainty of ~0.027%
 38 between calibrations is required.
- 39 2. What are the pros of SVPs vs cans?
 40

Small Volume Prover	Volumetric (Can) Prover
Prove in actual operating load conditions (flow, pressure, and temperature) by proving into customer loads	Lower cost to operate
Prove at multiple flow rates	Can visually see the quantity by viewing the neck
Establish multiple factors that can be applied	No moving part
Faster proving runs	
No need to pump back	
Gravimetric water draw more repeatable	

Lower prove uncertainty	
Higher turn down ratio	
Health Safety Security and Environment (HSSE) - reduced risk / impact to environment	
Digital history of meter performance at all flow rates with Meter Factor Control Chart (MFCC) to evaluate the health of each meter	
Help identify rack issues such as control valve issues as well as identify hydraulic issues that have a direct effect on measurements.	
Repeatability issues are easier to identify	
Repeatability is verified by making the comparison over 5 runs	Tank Provers repeatability is verified by one run after the initial meter factor change

- 1 3. How are SVPs certified?
 - 2 • NIST Traceable cans in a water draw lab, or NIST Traceable weights in a gravimetric lab.
 - 3
- 4 4. How do the computers calculate the final calibration result?
 - 5 • Comparing gross standard volume (GSV) of the meter vs the GSV of the prover
 - 6
- 7 5. How are peripheral equipment used in meter proving calibrated /verified (portable electronic thermometer
 - 8 (PET), Pressure Gauge, Transmitters)
 - 9 • PET calibrated via NIST certified
 - 10 • Pressure gauges NIST certified
 - 11 • PET and gauges used to determine if transmitters are in tolerance
 - 12

13 The submitter requested that this amendment be retroactive and that the item be a Voting item in 2023.

14

15 **Comments in Favor:**

16 **Regulatory:**
 17 •

18 **Industry:**
 19 •

20 **Advisory:**
 21 •

22 **Comments Against:**

23 **Regulatory:**
 24 •

25 **Industry:**
 26 •

27 **Advisory:**
 28 •

29 **Neutral Comments:**

- 1 **Regulatory:**
- 2 •
- 3 **Industry:**
- 4 •
- 5 **Advisory:**
- 6 •

7 **Item Development:**
 8 New

9 Additional letters, presentation and data may have been submitted for consideration with this item. Please refer to
 10 www.ncwm.com/publication-15 to review these documents.

LMD-23.4
<p>Regional recommendation to NCWM on item status:</p> <ul style="list-style-type: none"> <input checked="" type="checkbox"/> Recommend as a Voting Item on the NCWM agenda <input type="checkbox"/> Recommend as an Information Item on the NCWM agenda <input type="checkbox"/> Recommend as an Assigned Item on the NCWM agenda <i>(To be developed by an NCWM Task Group or Subcommittee)</i> <input type="checkbox"/> Recommend as a Developing Item on the NCWM agenda <i>(To be developed by source of the proposal)</i> <input type="checkbox"/> Recommend Withdrawal of the Item from the NCWM agenda <i>(In the case of new proposals, do not forward this item to NCWM)</i> <input type="checkbox"/> No recommendation from the region to NCWM <i>(If this is a new proposal, it will not be forwarded to the national committee by this region)</i>
<p>Comments and justification for the regional recommendation to NCWM: <i>(This will appear in NCWM reports)</i></p> <p>The following comments were received during the 2022 SWMA Annual Meeting:</p> <p>Mr. Prentiss Searles, American Petroleum Institute, gave a presentation on this item. He stated that the 50 gallon minimum draft size is not relevant to adequate testing and should be removed.</p> <p>Mr. Chesser, State of Arkansas, stated that SVP tolerances are much tighter than traditional methods.</p> <p>Mr. Keilty, Endress+Hauser, stated that he agrees with Mr. Searles and supports this item. He also stated that he believed this item could describe SVPs separately from fixed neck Provers. He recommends this move forward as a developing item.</p> <p>Mr. Nicholas Suemnick, Marathon Petroleum, supports this item.</p> <p>Mr. Brent Price, Gilbarco, stated that he supports this item with Mr. Searles changes.</p> <p>The SWMA S&T Committee recommends this item move forward as a Voting Item.</p>

11

1 **VTM – VEHICLE TANK METERS**

2 **VTM-18.1 S.3.1 Diversion of Measured Liquid and S.3.1.1. Means for Clearing the**
3 **Discharge Hose and UR.2.6. Clearing the Discharge on a multiple-product,**
4 **single discharge hose.**

5 *NOTE: At the 2020 Interim Meeting the Committee agreed to combine both VTM-18.1 and VTM-20.1. Both items*
6 *are now one item under VTM-18.1*

7 **Source:**

8 New York and NIST OWM (Carryover from 2018, VTM 1-B) and Murray Equipment, Inc., Total Control Systems

9 **Purpose:**

10 Provide specifications and user requirements for manifold flush systems on a multiple-product, single-discharge hose.
11 Recognize that there is a balance between a mechanism that provides an important safety benefit but also, if used
12 incorrectly, facilitates fraud. Ensure that VTM owners understand their responsibilities when installing such a system
13 and ensure uniformity in enforcement throughout the country and clarify the paragraph to protect vehicle motor fuel
14 quality, retain safe operating procedures when handling vehicle motor fuels, and to prevent fraud during delivery of
15 vehicle motor fuels from vehicle tank meters.

16 **Item Under Consideration:**

17 Amend Handbook 44, Vehicle-Tank Meters Code as follows:

18 Amend Handbook 44, Vehicle-Tank Meters Code as follows:

19 **S.3.1. Diversion of Measured Liquid.** – No means shall be provided by which any measured liquid can be diverted
20 from the measuring chamber of the meter or the discharge line thereof. However, two or more delivery outlets may
21 be installed if means are provided to ensure that:

- 22 (a) liquid can flow from only one such outlet at one time; and
23 (b) the direction of flow for which the mechanism may be set at any time is definitely and conspicuously
24 indicated.

25 This paragraph does not apply to the following:

- 26 (1) Equipment used exclusively for fueling aircraft.
27 (2) Multiple-product, single-discharge hose metering systems that are equipped with systems designed
28 to flush the discharge hose, provided the flushing system complies with the provisions of paragraph
29 S.3.1.1. Means for Clearing the Discharge Hose, **Multiple-Product, Single-Discharge Hose**
30 **Metering Systems.**

31 (Amended 2018 **and 20XX**)

32 **S.3.1.1. Means for Clearing the Discharge Hose, Multiple-Product, Single-Discharge Hose Metering**
33 **Systems.** - **Multiple-product, single-discharge hose** ~~M~~metering systems may be equipped with systems
34 specifically designed to facilitate clearing of the discharge hose prior to delivery to avoid product
35 contamination. In such systems. a valve to temporarily divert product from the measuring chamber of the
36 meter to a storage tank, shall be installed only if all the following are met:

- 37 (a) the discharge hose remains of the wet-hose type;
38 (b) the valve and associated piping are approved by the weights and measures authority having
39 jurisdiction over the device prior to commercial use;

- 1 (c) the valve is permanently marked with its purpose (e.g. flush valve);
- 2 (d) the valve is installed in a conspicuous manner and as far from the hose reel as practical;
- 3 (e) the system clearly and automatically indicates the direction of product flow during operation of the
- 4 flush system; and
- 5 (f) clear means, such as an indicator light or audible alarm, is used to identify when the valve is in *use*
- 6 on both quantity indications and any associated recorded representations (e.g., using such terms
- 7 as “flushing mode” or “not for commercial use”);
- 8 [nonretroactive as of January 1, 2024.]
- 9 (g) effective, automatic means shall be provided to prevent passage of liquid through any such flush
- 10 system during normal operation of the measuring system; and
- 11 [nonretroactive as of January 1, 2024.]
- 12 (h) no hoses or piping are connected to the inlet when it is not in use.
- 13 (Added 2018)(Amended 20XX)

14 **UR.2.6. Clearing the Discharge Hose.**

15 **UR.2.6.1. Clearing the Discharge Hose, General. – A manifold flush or similar system designed to**

16 **accommodate the flushing of product on single-hose, multiple-product systems is not to be used during**

17 **a commercial transaction. The following restrictions apply:**

- 18 a) **The inlet valves for the system are not to be connected to any hose or piping (dust covers are**
- 19 **permitted) when not in use.**
- 20 b) **When the flushing system is in operation, the discharge hose is only to be connected to the port**
- 21 **for the product type being flushed from the discharge line.**
- 22 c) **Following the flushing process, indications and recording elements must be reset to zero prior**
- 23 **to beginning a commercial delivery.**
- 24 **(Added 20XX)**

25 **UR.2.6.2. Minimizing Cross Contamination. – When dissimilar products are dispensed through a**

26 **single meter, the user shall take steps to ensure the system is properly flushed to minimize the potential**

27 **for cross contamination of product in receiving tanks on subsequent deliveries. Dispensing products**

28 **having radically different characteristics (e.g., gasoline and diesel fuel) through a single meter delivery**

29 **system is not recommended.**

30 **(Added 20XX)**

31

32 **UR.2.6.3. Records.** Whenever, prior to delivery, a different product is pumped through the discharge hose

33 to avoid contamination, a record including the date, time, original product, new product, and gallons pumped

34 shall be maintained. These records shall be kept for a period of 12 months and available for inspection by the

35 weights and measures authority.

36 (Added 2018)

37 **Background/Discussion:**

38 This item has been assigned to the submitter for further development. For more information or to provide comment,

39 please contact:

40 Mr. Jim Willis

1 New York Department of Agriculture and Markets
2 518-485-8377, james.willis@agriculture.ny.gov

3 This item was one of two separate parts of VTM-1 (previously VTM-1A and VTM-1B) considered by the Committee
4 at the 2018 NCWM Annual Meeting. The item voted on at the 2018 Annual Meeting, VTM-1A was adopted and
5 VTM-1B was assigned an Informational status and carried-over to the next cycle.

6 Manifold flush systems are typically used on VTM's with multiple compartments, delivering multiple products
7 through a single hose. The purpose of the system is to allow the driver a means of clearing the hose of product prior
8 to delivery (e.g., clearing the hose of diesel fuel before delivering clear kerosene). These types of systems are often
9 marketed as a safety feature in that it eliminates the need for the driver to climb on top of the truck to clear the hose.
10 Such systems are also useful in helping avoid cross-contamination. Typically, the driver attaches the nozzle to the
11 manifold and pumps product back into the supply tank via the manifold until the previous product is flushed from the
12 hose. There is often a sight gauge which allows the driver to tell when the product is flushed.

13 The obvious concern is that this makes it very easy for the driver to circulate product through the meter prior to
14 delivery, which goes against S.3.1. It should be noted that it also goes against S.3.1. when the driver climbs on top of
15 the tanker and clears the hose. The submitter has voiced concerns involving the safety of this practice noting that the
16 operator could be subject to falls from the tanker. The distance between the flush system and the hose reel is also a
17 factor in how easy it is for the driver to facilitate fraud.

18 Manifold flush systems are available from OEMs and can be found in various catalogs. Looking on multiple websites,
19 these systems are being installed across the country and for some manufacturers seem to be standard equipment for
20 new trucks. The submitter of VTM-1 has also seen these systems installed on trucks that are for sale where the seller
21 notes the system as a selling point. He can foresee these systems being mandated in the future as a safety requirement
22 and would like W&Ms to have a clear policy before that happens.

23 Another concern is with systems fabricated onsite. These systems are often difficult to distinguish and installed in an
24 inconspicuous manner. While the submitter of VTM-1 has ordered many of these systems out-of-service until
25 repaired, it can be frustrating for the owner because the truck was used in another state for years and approved by
26 weights and measures jurisdiction in the other state. This lack of uniformity is problematic for both officials and
27 private industry.

28 NCWM 2018 Annual Meeting: The Committee heard comments from OWM that this item needed additional work
29 to address concerns that had been identified in OWM's 2018 Interim Meeting (and earlier) analyses. While there are
30 clear benefits to improving safety when flushing hoses, OWM and others have noted these systems can facilitate fraud
31 without appropriate safeguards in place. OWM noted the language in the Item Under Consideration in the
32 Committee's 2018 Interim Report would:

- 33 1. provide an (unintentional) exemption to the provisions for "diversion of product" for *all* single meter,
34 multiple product, multiple compartment systems;
- 35 2. would (unintentionally) require all such systems to be equipped with a manifold flush system;
- 36 3. fail to include requirements for the system to clearly indicate (on both display and recorded representations)
37 when the flush system is in operation; and
- 38 4. fail to include limitations on how the user is permitted to appropriately use these systems.

39 In discussing the changes OWM felt were needed prior to the Annual Meeting, the submitter and OWM agreed that
40 some of OWM's proposed changes would be considered editorial and others technical in nature. Since other than
41 editorial changes could affect the Voting status of the item, OWM offered the following two courses of action for the
42 Committee to consider:

- 43 1. Downgrade the item to Informational to allow time to address all the changes that are needed; or

1 2. Split the item into two parts to allow the portion of the item needing only editorial changes to move forward
2 for vote; and carryover the remaining portion to allow time for it to be further developed and considered
3 during the next NCWM cycle.

4 Rather than hold up the entire item to be considered in the next Conference cycle, the submitter requested the item be
5 split into two parts to allow the completed portion, including the editorial changes, to move forward for vote.

6 NCWM 2019 Interim Meeting: The Committee heard comments to Agenda Item VTM-1 as well as position
7 statements from MMA that they objected to manifold flush systems. NIST OWM provided an analysis to the
8 Committee prior to the Interim Meeting. The comments heard during the open hearing and/or received prior to the
9 Interim meeting are summarized below:

10 Mr. Hal Prince (FL) stated that it was missing any inclusion for limitation of use, such as when delivering multiple
11 products. Mr. Prince suggested that the Committee consider language forwarded by the SWMA in its 2018 Annual
12 Report. Mr. Prince also suggested that the item be kept developmental. Mr. Dan Murray (Murray Equipment, Total
13 Controls System) stated that Manifold Flush Systems were a big problem in Europe where they are permitted. Mr.
14 Murray suggested these systems could facilitate fraud and NTEP should carefully consider this before granting
15 approval. These systems should also be sealed. Mr. Murray's opinion was that the item should be withdrawn. Mr.
16 Dmitri Karimov speaking on behalf of Meter Manufacturers Association, stated that MMA objected to manifold flush
17 systems.

18 NIST OWM agreed with the WWMA and the CWMA that this item is fully developed and agreed with assigning it a
19 voting status. OWM provided the following review of the operation of the equipment, proposed changes, and
20 additional points to consider:

- 21 • At the 2018 NCWM Annual Meeting the Conference voted to allow an exemption to S.3.1. for Manifold
22 Flush Systems, which is currently in the 2019 HB 44 VTM code.
- 23 • S.3.1. states “no means” shall be provided to divert liquid from the measuring chamber of the meter or the
24 discharge line.
- 25 • A manifold flush system allows liquid to be diverted from the discharge line on single hose multi-
26 compartment VTMs so that liquid of one product is not mixed with liquid of another in the discharge line.
- 27 • Without a manifold flush system, the operator must manually return the product to the correct compartment
28 to clear the discharge line before using another product.
- 29 • There are safety hazards with manually returning the product to storage (operator climbing on top of tank
30 and lifting hose to return the product. There are also safety concerns when not properly clearing the discharge
31 lines prior to delivering a different product and because of these safety concerns it was reported that more of
32 these systems will likely be installed on single hose multicompartments trucks.
- 33 • Although safety is a high priority, the “means” used to return product back to storage is not as visible and
34 makes facilitation of fraud a high possibility.
- 35 • The additional changes proposed are intended to ensure such systems are designed such that they do not
36 facilitate fraud; help ensure owners understand their responsibilities when installing such a system; and
37 ensure uniformity in enforcement throughout the country.
- 38 • The changes reflect the suggested language from OWM's previous analysis and incorporate comments
39 received from the MMA and others during the 2018 Annual meeting.

1 Non-retroactive dates may need to be added to allow time for manufacturers of flush systems to incorporate the
2 safeguards into their systems. During the committee's work session, the Committee considered the comments
3 received during the Interim Meeting open hearings and recommended a voting status for this item.

4 NCWM 2019 Annual Meeting: The Committee supported amendments proposed to subparts (f) and (g) based upon
5 statements from the submitter (NY) indicating that manufacturers of manifold flush systems will need additional time
6 to incorporate the safeguards into their systems. The Committee also agreed to place the item on the voting consent
7 calendar as amended, and as shown in the Item Under Consideration.

8 During the open hearing sessions, the Committee heard comments from NIST OWM's Mrs. Tina Butcher offering a
9 revision of S.3.1.1.(f), suggesting this portion be split into separate bullet points. Also heard were comments from
10 Mr. Jim Willis (NY) in support of NIST OWM's suggestion and his recommendation for making this a nonretroactive
11 requirement to allow manufacturers time to accommodate the necessary changes.

12 During the voting session, it was requested this item be removed from the voting consent calendar and voted on
13 separately. The item failed to receive enough votes for adoption and was therefore returned to the Committee.

14 NCWM 2020 Interim Meeting: The Committee heard from Ms. Butcher (NIST OWM) who recommended that VTM-
15 18.1 and VTM-20.1 be combined because both items address manifold flush systems, but VTM 18-1 does not restrict
16 the use of the system to certain products and VTM 20-1 restricts the use of the system to home heating fuel. Mrs.
17 Butcher recommended that the combined item be given a developing status to address the design and use of these
18 systems adequately. Mrs. Butcher also recommended improvements to VTM 18-1 and VTM 20-1.

19 Mr. Dmitri Karimov (MMA) agreed with the language proposed in VTM 18-1 and acknowledged that there is value
20 in the alternative proposal VTM-20.1 and supports combining both proposals into one. Mr. Hal Prince (FL) also
21 agreed that Item VTM-18.1 and VTM-20.1 be combined and given a developing status. Mr. Prince expressed a
22 willingness to work with submitters to further develop the items and noted that he has concerns with cross-
23 contamination caused by these systems. Mr. Jim Willis agreed with Mrs. Butcher's statements. Mr. Karimov
24 recommended including more categories for types of fuels in the proposal is important such as flammable, explosive,
25 etc. Mr. John Hathaway (Murray Equipment) submitter of VTM-20.1 expressed interest in working together with the
26 submitters of VTM-18.1.

27 During the Committee's work session, the committee agreed that this item, VTM-18.1 should be combined with VTM-
28 20.1 and be given a developing status to allow the submitters of both items to work together towards resolving the
29 conflicts in these two items.

30 NCWM 2020 Annual Meeting: Due to the 2020 Covid-19 pandemic, this meeting was adjourned to January 2021, at
31 which time it was held as a virtual meeting. Due to constraint of time, only those items designated as 2020 Voting
32 Items were addressed. All other items were addressed in the subsequent 2021 NCWM Interim Meeting.

33 NCWM 2021 Interim Meeting: The Committee heard from Mr. Mike Smith (NY) who supports VTM 18.1 as a
34 Developing item and he agreed to work with the other submitters of this item on paragraphs S.3.1.1. (f) and (g) and to
35 address contamination. Mr. Hal Prince (FL) supports a Developing status for VTM-18.1 and noted that with VTM-
36 18.1 there will be issues with fuel contamination. The concern raised in previous discussions was that if these manifold
37 systems are used with multi-product, single discharge hose dispensers for the delivery of both motor fuels and home
38 heating fuels, a small amount of home heating fuel mixed with a motor fuel could be problematic. It was also noted
39 that these fuels could get contaminated repeatedly whenever there is a change from one fuel to another and that there
40 is also the safety issue of flashing when mixing a gasoline with diesel or kerosene. Ms. Diane Lee report that VTM-
41 18.1 and VTM-20.1 conflict. VTM-20.1 restricts the use of these systems to be used with only home heating fuels.
42 Dmitri Karimov (MMA) noted if VTM-18.1 is adopted then VTM-20.1 would not be required. Mr. Charles
43 Stutesman, (KS) was not sure if VTM-18-1 and VTM-20-1 were being discussed together and it was pointed out that
44 it was agreed that they be combined at the 2020 interim meeting. Mr. John Hathaway (Total Control Systems) agreed
45 with a Developing status for this item and noted that the changes to Paragraphs (f) and (g) would help to address some
46 of the issues that were raised. The committee agreed to a Developing status for VTM-18.1 and to Withdraw VTM-
47 20.1. The committee also stated that any concerns with contamination and safety should also be addressed.

1 NCWM 2021 Annual Meeting: Mr. Jim Willis (NY, submitter) reported that there are no updates due to the pandemic
 2 and requested that it remain under Developing status. NIST OWM included written comments in its analysis.

3 NCWM 2022 Interim Meeting:

4 Item under consideration presented to 2022 NCWM Interim meeting as:

5 **S.3.1. Diversion of Measured Liquid.** – No means shall be provided by which any measured liquid can be diverted
 6 from the measuring chamber of the meter or the discharge line thereof. However, two or more delivery outlets may
 7 be installed if means are provided to ensure that:

8 (b) liquid can flow from only one such outlet at one time; and

9 (b) the direction of flow for which the mechanism may be set at any time is definitely and conspicuously
 10 indicated.

11 This paragraph does not apply to the following:

12 (2) Equipment used exclusively for fueling aircraft.

13 (2) Multiple-product, single-discharge hose metering systems that are equipped with systems designed
 14 to flush the discharge hose, provided the flushing system complies with the provisions of paragraph
 15 S.3.1.1. Means for Clearing the Discharge Hose, **Multiple-Product, Single-Discharge Hose**
 16 **Metering Systems.**

17 (Amended 2018 **and 20XX**)

18 **S.3.1.1. Means for Clearing the Discharge Hose, Multiple-Product, Single-Discharge Hose Metering**
 19 **Systems.** - **Multiple-product, single-discharge hose** ~~M~~metering systems may be equipped with systems
 20 specifically designed to facilitate clearing of the discharge hose prior to delivery to avoid product
 21 contamination. In such systems, a valve to temporarily divert product from the measuring chamber of the
 22 meter to a storage tank, shall be installed only if all the following are met:

23 (i) the discharge hose remains of the wet-hose type;

24 (j) the valve and associated piping are approved by the weights and measures authority having
 25 jurisdiction over the device prior to commercial use;

26 (k) the valve is permanently marked with its purpose (e.g. flush valve);

27 (l) the valve is installed in a conspicuous manner and as far from the hose reel as practical;

28 (m) the system clearly and automatically indicates the direction of product flow during operation of the
 29 flush system; and

30 (n) clear means, such as an indicator light or audible alarm, is used to identify when the valve is in use
 31 **on both quantity indications and any associated recorded representations (e.g., using such terms**
 32 **as “flushing mode” or “not for commercial use”);**

33 **[nonretroactive as of January 1, 2024.]**

34 (o) **effective, automatic means shall be provided to prevent passage of liquid through any such flush**
 35 **system during normal operation of the measuring system; and**

36 **[nonretroactive as of January 1, 2024.]**

37 (p) no hoses or piping are connected to the inlet when it is not in use.

1 (Added 2018)(Amended 20XX)

2 **UR.2.6. Clearing the Discharge Hose.**

3 **UR.2.6.1. Clearing the Discharge Hose, General. – A manifold flush or similar system designed to**
4 **accommodate the flushing of product on single-hose, multiple-product systems is not to be used during**
5 **a commercial transaction. The following restrictions apply:**

- 6 d) **The inlet valves for the system are not to be connected to any hose or piping (dust covers are**
7 **permitted) when not in use.**
- 8 e) **When the flushing system is in operation, the discharge hose is only to be connected to the port**
9 **for the product type being flushed from the discharge line.**
- 10 f) **Following the flushing process, indications and recording elements must be reset to zero prior**
11 **to beginning a commercial delivery.**

12 **(Added 20XX)**

13 **UR.2.6.2. Records.** Whenever, prior to delivery, a different product is pumped through the discharge hose
14 to avoid contamination, a record including the date, time, original product, new product, and gallons pumped
15 shall be maintained. These records shall be kept for a period of 12 months and available for inspection by the
16 weights and measures authority.

17 (Added 2018)

18 The Committee heard from Mr. Jim Willis (NY, submitter) and provided an update that contained amended language
19 with modifications to UR.2.6.2 and creating UR.2.6.3. The amendments were agreed upon by the other joint
20 submitters, NIST OWM and Murray Equipment. He stated that the new proposed language would hold device owners
21 responsible for ensuring there is no cross-contamination of fuels and also allows jurisdictions to prohibit using
22 manifold flush systems or dispensing dissimilar products through a single meter. The Meter Manufacturers
23 Association, Mr. John Hathaway (Murray Equipment), Ms. Cheryl Ayer (NH), and Mr. John McGuire (NJ) also voiced
24 support for the amended language and urged the item be given a voting status. Mr. Hal Prince (FL) opposes the entire
25 item, indicating the use of a single meter to dispense different products is not legal in his state and has concerns of
26 cross-contamination of fuel. During the Committee work session, the committee assigned this item a voting status
27 with the amended language seen above as the item under consideration. The item as presented to the 2022 NCWM
28 interim meeting can be seen below the item under consideration.

29 NCWM 2022 Annual Meeting: The Committee heard comments on the item as printed in Publication 16 and
30 introduces during the NCWM 2022 Interim meeting.

31 Mr. Dmitri Karimov spoke on behalf of the MMA in support of the item, as its helps minimize fraudulent activities
32 and increase safety for operators.

33 Mrs. Tina Butcher of NIST OWM, as one of the submitters of the item expressed support as a voting item. She
34 commented the item has undergone a significant amount of work in the past two cycles, collaboration with NIST
35 OWM, Murray Equipment, and the state of New York to address previous concerns. Mrs. Butcher added the item
36 addresses safeguards to prevent product contamination, limit fraud, and adds distinct safety advantages. Mrs. Butcher
37 referred to the written NIST OWM analysis for details. She added this may be a widespread practice in many
38 jurisdictions and this proposal provides requirements to limit fraud during such deliveries. Mrs. Butcher added a
39 reminder that the implementation and enforcement of these requirements can be administered and controlled through
40 jurisdictional legislative means.

41 Mr. Hal Prince (FL) commented in opposition of the item, noting it is not appropriate for a delivery through a single
42 meter, single hose system where contamination can occur. Mr. Prince was concerned with UR.2.6.2., adding the
43 language is misleading when referring to avoiding contamination, where the act of flushing a meter and hose is

1 introducing contamination. Mr. Prince commented if the item were to pass, he would like to see added language to
2 make clear users of such devices should confirm with the jurisdiction before use.

3 Mr. Jim Willis (NY) provided comments in support of the item. He referred to these device types currently used by
4 small businesses throughout New York State, noting this would provide a safer method to clear discharge hoses and
5 not require operators to climb on top of the truck to clear discharge hoses. Mr. Willis is in support of the item.

6 Mr. Charlie Stutesman (KS) commented the item provides a way to address safety concerns by not requiring operators
7 to climb on top of the delivery truck to clear discharge hoses. He also noted the increased number of single meters,
8 single hoses with multi-calibrated capabilities seen in the field and would like to see a way to address these meter
9 types. Mr. Stutesman questioned if existing meter manifolds can be retrofitted to meet these requirements, requesting
10 clarification to address the retroactive versus nonretroactive dates.

11 Mr. Jon Hathaway (Murray Equipment) commented in support of the item, adding that product contamination is not
12 eliminated, but minimized with these requirements, adding UR.2.6.2. addresses concerns. Mr. Hathaway stated vehicle
13 tank meter manufacturers support and are in agreement to not have dissimilar fuels metered through a single system.
14 Metering of dissimilar fuels (gasoline v. diesel) is completed through a separate metering system.

15 Mr. Kevin Schnepf (CA) expressed concern with the terms, “radically different” and “not recommended”, as these
16 terms are not well defined and provide no authority for enforcement. Mr. Schnepf also stated his concerns with the
17 potential for contamination.

18 Ms. Angela Godwin (San Bernadino County, CA) was concerned with the nonretroactive versus the retroactive status
19 and encourages the consideration of any impact this may have.

20 Ms. Cheryl Ayer (NH) expressed her support of the item with a retroactive date.

21 Mr. Jim Willis (NY) offered suggestive language to address concerns about jurisdictional discretion.

22 The Committee did not recommend any changes to the item as written in Publication 16. The item was assigned a
23 voting status during the NCWM 2022 annual meeting where the item was voted upon and failed to meet the required
24 number of votes by membership. The item was returned to committee.

25 **Regional Associations’ Comments:**

26 WWMA 2021 Annual Meeting: Matt Douglas (California - DMS): California supports further development. Has
27 there been any further development since annual meeting?

28 The WWMA S&T Committee recommends the status remain Developmental. The Committee recommends that the
29 submitters (NIST, New York and Murray Equipment) continue their work together to further develop the item.

30 SWMA 2021 Annual Meeting: No comments were received on this item. NIST requests this item remain
31 Developmental.

32 This committee recommends the status remain Developing at the request of the submitter.

33 CWMA 202. Annual Meeting: No comments from the floor.
34 The CWMA S&T Committee recommends this item to remain a voting item.

35 NEWMA 202. Annual Meeting: Mr. Jim Willis (NY), Mr. John McGuire (NJ), Mr. Ethan Bogren (Westchester
36 County, NY) and Ms. Tina Butcher (NIST OWM) rose in support of the item as voting.
37

38 After hearing comments from the floor, the committee considered the item to be fully developed and recommended
39 that the item retains voting status.

1 Additional letters, presentation and data may have been submitted for consideration with this item. Please refer to
2 www.ncwm.com/publication-15 to review these documents.

VTM-18.1	
Regional recommendation to NCWM on item status:	
<input checked="" type="checkbox"/> Recommend as a Voting Item on the NCWM agenda <input type="checkbox"/> Recommend as an Information Item on the NCWM agenda <input type="checkbox"/> Recommend as an Assigned Item on the NCWM agenda <i>(To be developed by an NCWM Task Group or Subcommittee)</i> <input type="checkbox"/> Recommend as a Developing Item on the NCWM agenda <i>(To be developed by source of the proposal)</i> <input type="checkbox"/> Recommend Withdrawal of the Item from the NCWM agenda <i>(In the case of new proposals, do not forward this item to NCWM)</i> <input type="checkbox"/> No recommendation from the region to NCWM <i>(If this is a new proposal, it will not be forwarded to the national committee by this region)</i>	
Comments and justification for the regional recommendation to NCWM: (This will appear in NCWM reports)	
The following comments were received during the 2022 SWMA Annual Meeting: Jason Glass, State of Kentucky, a member of the NCWM S&T Committee, proposed the following amendment to this proposal: <u>VTM 18.1</u> <u>UR 2.6.2.</u> <u>This system shall not be used for products, that when exposed to one another, will cause either of those products to not meet their respective quality specifications.</u> Mr. Prince, State of Florida, stated that he has been concerned with weak language on cross contamination in the past. Mr. Keilty, Endress+Hauser, stated that “electronic” should be added between hose and metering on page 187 line 10. The SWMA S&T Committee recommends moving this item forward as a Voting Item with the proposed language from Mr. Glass replacing the current UR 2.6.2. language.	

3

4 **VTM-20.2 A Table T.2. Tolerances for Vehicle Mounted Milk Meters.**

5 *NOTE: This item was revised based on changes that were made by the Committee at the 2021 Interim Meeting. The*
6 *item under consideration was removed from the voting consent calendar at the 2021 Annual Meeting and the S&T*
7 *Committee made this a developing item)*

8 **Source:**
9 POUL TARP A/S

10 **Purpose:**
11 Change tolerances to accommodate more efficient milk-metering systems.

1 **Item Under Consideration:**
 2 Amend Handbook 44, Vehicle-Tank Meters Code as follows:

3 **T.2. Tolerance Values.** – Tolerances shall be as shown in Table 1. Accuracy Classes and Tolerances for Vehicle-
 4 Tank Meters Other Than Vehicle-Mounted Milk Meters and Table 2. Tolerances for Vehicle-Mounted Milk Meters.
 5 (Amended 1995, 20XX)

Table 2. Tolerances for Vehicle-Mounted Milk Meters		
Indication (gallons)	Maintenance Tolerance (gallons)	Acceptance Tolerance (gallons)
100	0.5	0.3
200	0.7	0.4
300	0.9	0.5
400	1.1	0.6
500	1.3	0.7
Over 500	Add 0.002 gallon per indicated gallon over 500	Add 0.001 gallon per indicated gallon over 500

6 (Added 1989)

Table 2. Tolerances for Vehicle-Mounted Milk Meters		
	Acceptance Tolerance	Maintenance Tolerance
Complete Measuring System	0.5%	0.5%
Meter Only	0.3%	0.3%

7 (Amended 20XX)

8 **Background/Discussion:**

9 A Milk Meter Tolerance Task Group was formed and assigned to this item. Please contact the task group chair for
 10 more information:

11 To Be Determined

12 Milk Meter Tolerance Task Group
 13 Phone, Email

14 Existing tolerances are based on the accuracy of the Flow meter itself. The proposed Tolerances are based on Milk
 15 Metering Systems where the magnetic flow meter is a part of the Milk Metering system handling milk containing air.

16 The accuracy of the Flow meter will always be influenced by the way it is used. The only way you can obtain the
 17 accuracy described by the manufacture is when the flow meter is operating as a “stand alone” unit and, equally
 18 important, only if the product passing through the flow meter is complete air-free.

19 The submitter provided the following:

20 During the past 20 years, the need for improved efficiency in the collection of milk has resulted in the use of milk
 21 pumping equipment being installed on milk tankers.

1 One of the most obvious places for a modern Dairy to optimize is the amount of time that the milk tanker uses to
2 make a collection. If you can reduce the collection time at each farmer, the Dairy will be able to get a significant
3 reduction in collection and transport cost for the benefit of the Farmer, Consumer and the Dairy itself. At the same
4 time, you will get an environmental benefit as a result of reduced CO2 in the milk collection process.

5 The consequence of introducing pump systems on milk tankers is that it causes air to be mixed with the milk
6 which again will influence the accuracy of the magnetic flow-meter mounted in the system. Milk entrains air
7 unlike petroleum liquids which do not. As you know, the flow meter will count anything that passes through the
8 meter – liquid as well as air – and it is therefore essential that as much air as possible is removed from the milk
9 before it reaches the flow-meter. However, it is widely recognized that it is not possible to remove all the air from
10 the milk, which will result in an inaccuracy.

11 It is therefore essential that the tolerances for vehicle mounted milk pump systems using magnetic flow-meters
12 for determining milk volume reflects today's way of collecting milk. This means that existing Tolerance for milk
13 meters cannot be used when the milk meter is a part of a system where different system parts will influence the
14 accuracy of the count. Such milk metering systems will need to be classified with their own tolerances.

15 Based on our 25 years of experience as a manufacturer of these systems and more than 3000 installations on milk
16 trucks operating in more than 15 countries, we would like to propose that the Tolerance for Vehicle Mounted
17 Milk Metering Systems is changed from 0.3% to 0.5% and that the tolerances will be listed and classified
18 separately and not be associated with products from the oil industry. Our proposal is consistent with Weights &
19 Measures tolerances accepted around the world.

20 We hope that the NCWM will consider our proposal and we will be more than happy to meet with you and answer
21 any questions you may have. We believe that a change of Tolerance is necessary in order for the Handbook 44 to
22 reflect today's milk collection and the technical progress within milk collection.

23 Yours sincerely

24

25 Poul Tarp

26 President POUL TARP A/S

27 The POUL TARP milk pump system holds an MID approval which is recognized and in accordance with guidelines
28 and standards described in the **OIML - INTERNATIONAL ORGANIZATION OF LEGAL METROLOGY**

1 FLOW COMPUTERS REGULATION IN THE US:

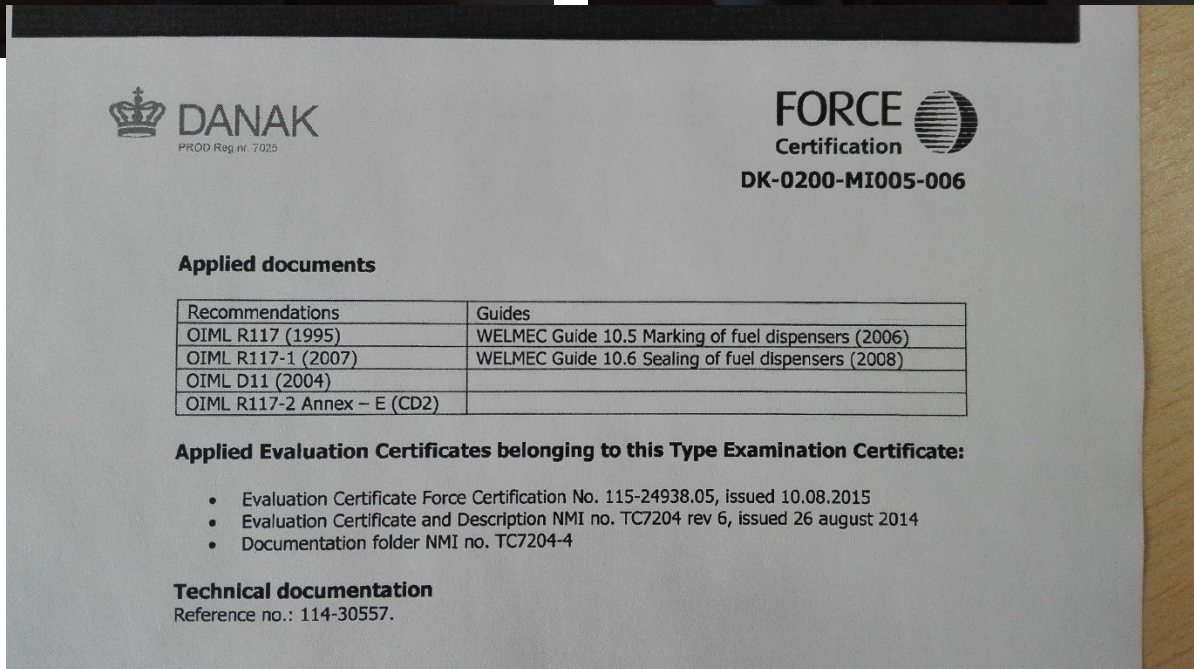
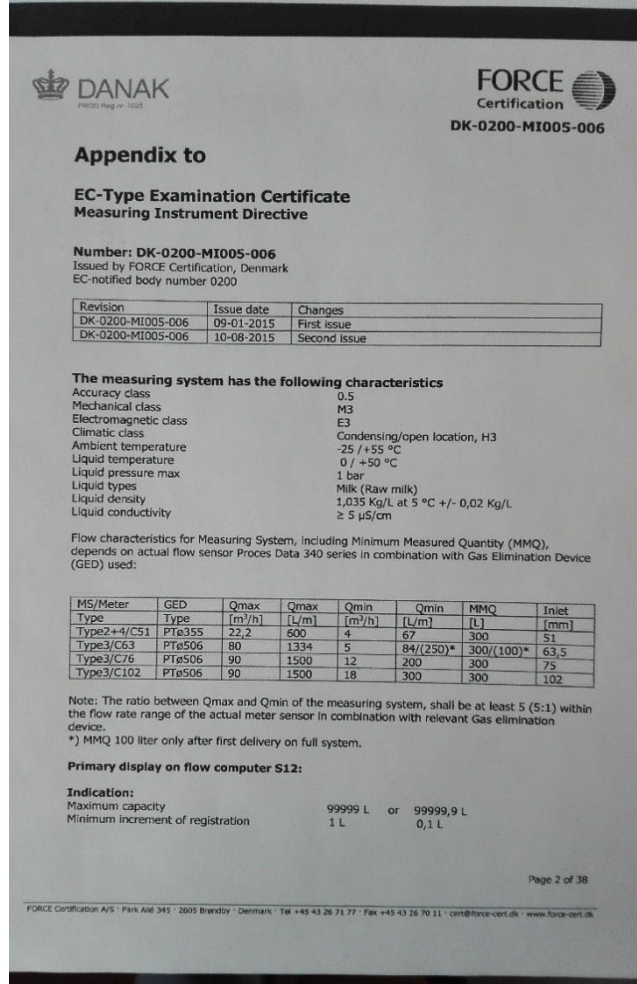

- 1 The standards related to metrological aspects come from OIML R117-1 for liquids (Dynamic measuring systems for
- 2 liquids other than water, part 1: Metrological and technical requirements) and documents D11 (General requirements
- 3 for electronic measuring instruments) and D31 (General requirements for software-controlled measuring instruments)
- 4 from OIML

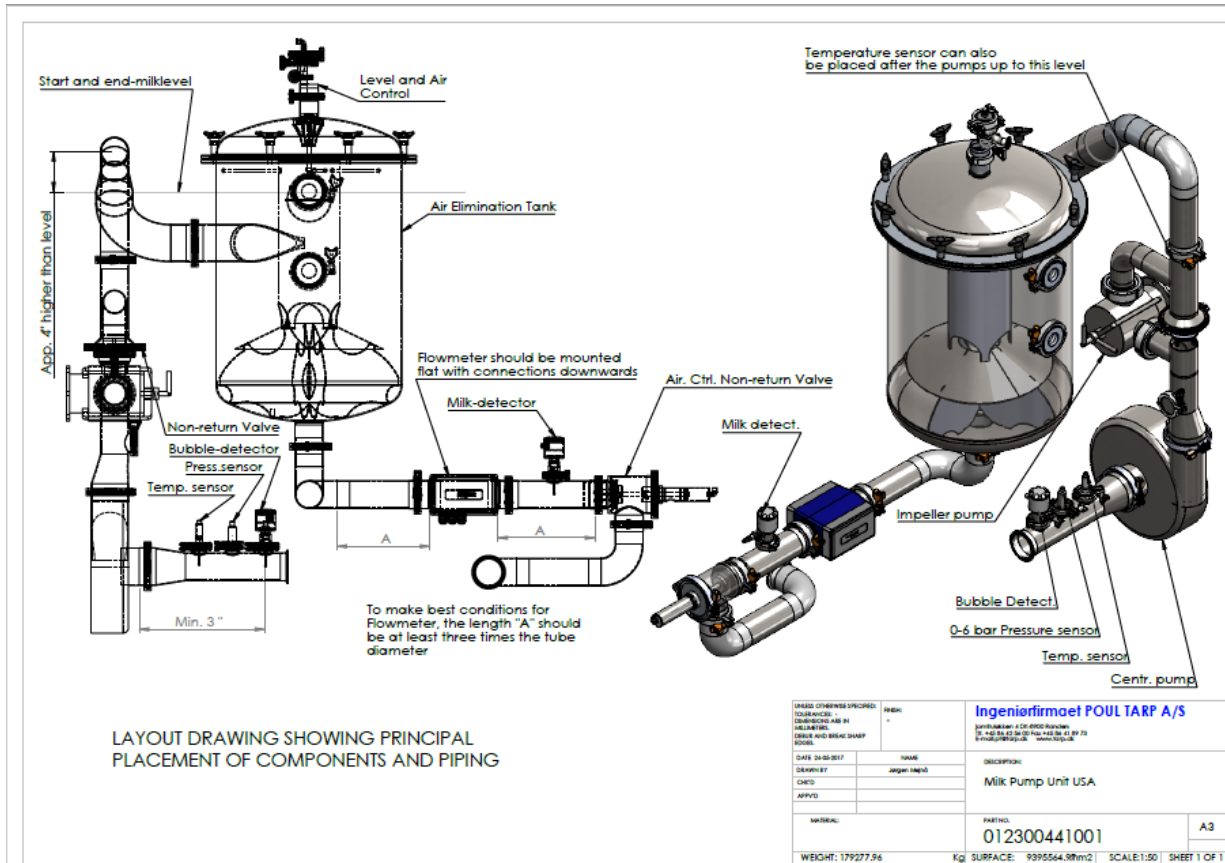

5 NCWM 2020 Interim Meeting: Mr. Carey McMahon (Poul Tarp) provided a presentation on his company’s VTM
6 milk metering system advocating for expanding tolerances for these systems.

7 Ms. Leigh Hamilton (Piper) provided a presentation concerning the piper system and stated in her presentation that
8 piper currently has an approved NTEP certificate for their device that is in service in the U.S. Ms. Leigh opposes this
9 item to increase the tolerances for milk meters and noted in her presentation that there may not be a need to increase
10 the tolerances in order to move forward in allowing innovation in milk measurements.

11 Mr. Charles Stutesman (KS) provided a presentation on research that KDA has done on the history of 3 HB 44 Codes
12 (3.31. VTMs, 3.35. Milk Meters, and 4.42. Farm Milk Tanks) and the issue of Piper’s NTEP Certificate. Mr.
13 Stutesman discussed complications involved in measurement of product using various methods and potential
14 shortcomings of Piper’s NTEP Certificate.

15 Mr. Doug Musick (KS) stated that he does not believe there is enough information presented to change existing
16 tolerances and noted that the Piper system was only evaluated for accuracy up to a measurement of 300 gallons. He
17 also noted that he believes that Piper’s certificate should be amended to qualify the system for draft sizes up to 300
18 gallons. Mr. Mike Keilty (Endress + Hauser) commented that he had concerns with Piper’s certificate. Ms. Hamilton
19 noted that Piper followed and followed guidelines as provided during the NTEP evaluation. Ms. Diane Lee (NIST
20 OWM) stated that the committee may want to consider a developing status for this item and that more information is
21 needed concerning air elimination methods for milk metering systems.

1 A representative from the Dairy Farmers of America, stated that they oppose the increase in tolerance but supports the
2 use of VTM metering systems. Mr. Carey McMahon (Poul Tarp) pointed out that the Poul Tarp system can be accurate
3 for any size measurement, but the beginning and end of the measurement would not be accurate measures (within
4 tolerance) due to entrained air in the product when the flow is not uniform. Mr. Dmitri Karimov (MMA) stated that
5 the proposal should be further developed and pointed out that due to the tolerance structure becoming more stringent
6 as the volume of the measurement increases, the acceptance tolerance at 500 gallons is unreasonable. Mr. Hal Prince
7 (Florida) stated that he does not agree with expanding the tolerances. Mr. Prince believes that air elimination should
8 be the focus and that the proposal should be assigned to a task group. Mrs. Tina Butcher (NIST OWM) noted that
9 testing should be performed using multiple quantities and flowrates. Mr. Charles Stutesman (KS) pointed out that
10 confusion is generated by multiple HB 44 codes addressing the measurement of milk and that the proposal should be
11 assigned to a TG to sort this out. Mr. Stutesman also pointed out there is no requirements in HB 44 for air elimination
12 pertaining to milk metering in these codes. Mrs. Butcher noted that the current HB 44 requirements may not be
13 flexible enough for this new technology and that the existing codes may need to be reviewed and updated.

14 Ms. Leigh Hamilton (Piper) stated that this is not simply a consideration of only a change in tolerances. There are
15 other requirements (currently in the OIML standard) that should also be considered in making any changes to the
16 existing HB 44 requirements. Mr. Mike Keilty (Endress+Hauser) stated that air elimination is a difficult problem to
17 mitigate and noted that he is not sure if it is necessary to expand the existing tolerances or make other amendments.
18 Mr. Carey McMahon (Poul Tarp) stated that using the existing HB 44 tolerances in the VTM Code, at a draft of 5000
19 gallons, the tolerance value is highly unreasonable (KS) noted that the type evaluation performed on the Piper system
20 was limited to a draft of 300 gallons. If evaluation had included other draft sizes, the Piper system may have failed
21 the testing.

22 Mr. Ken Ramsburg (MD) stated that the proposal should be given a developing status. Mr. Ramsburg agreed that
23 there is no existing requirement for this type of system addressing air elimination and stated that the flow meter, air
24 eliminator, plumbing, and pumps all need to be considered during evaluation and the evaluation should be conducted
25 on the system.

26 Mr. Tim Chesser (AR) questioned whether the flow meter used in the system is appropriate and noted that there are
27 many unanswered questions surrounding this issue. Mr. Jim Willis (NY) recommended a developing status for this
28 item. Mr. Kevin Schnepf (CA) stated that although he is opposed to relaxing existing tolerances, he supports the
29 development of this proposal by an assigned task group.

30 During the Committee's work session, the committee agreed that this item has merit and should be given an Assigned
31 status. The charge to the assigned task group will be to address three HB 44 codes (VTM, Farm Milk Tanks and Milk
32 meters) to review the requirements and tolerances found in these codes and assess the need for changes.

33 NCWM 2020 Annual Meeting: Due to the 2020 Covid-19 pandemic, this meeting was adjourned to January 2021, at
34 which time it was held as a virtual meeting. Due to constraint of time, only those items designated as 2020 Voting
35 Items were addressed. All other items were addressed in the subsequent 2021 NCWM Interim Meeting.

36 NCWM 2021 Interim Meeting: The Committee heard from Mr. Charles Stutesman (KS, Chair of the Milk Meter Task
37 Group) who gave an update on the task group activities. Mr. Stutesman reported that the Milk Meter Task group
38 worked via e-mail communication and reviewed and discussed the proposed Milk Meter Tolerances in Agenda item
39 VTM-20.2. The Milk Meter Task Group also discussed the tolerances that are included in NIST HB 44 for Milk
40 meters in various parts of HB 44 which include the VTM, Section 3.31, Farm Milk Tanks, Section 4.42., Mass Flow
41 Meters, Section 3.37, and Milk Meters, Section 3.35. Mr. Stutesman also reported that the task group reviewed OIML
42 tolerances for milk meters. Mr. Stutesman stated that after a review of the various tolerances, the task group agreed
43 that the OIML tolerances provide tolerances that encompassed the system of measuring milk and not just a tolerance
44 for the performance of the meter. The Milk Meter Task group agreed with proposing the use of the OIML milk meter
45 tolerance as the milk meter tolerances in the VTM code. Mr. Stutesman provided a copy of the proposed changes to
46 VTM-20.2. The proposed tolerances will align the tolerances in the VTM Code for Milk Meters with OIML Milk
47 Meter Tolerances. Mr. Stutesman requested that this item move forward as a Voting item. The Committee also heard
48 from Clark Cooney who noted that he supported the items as Developing because one company mentioned meeting

1 the existing tolerances. It was mentioned that the company’s testing was only performed over a limited range of
2 volumes.

3 During the committees work session the committee agreed with the proposal from the milk meter task group to adopt
4 OIML tolerances for milk meters in the VTM code, that this item be given a voting status, and that the item under
5 consideration be replaced with the work groups proposal to adopt OIML tolerances. The committee also agreed with
6 expanding the task group to address other milk meter codes in HB 44. The Item Under Consideration above are the
7 tolerances agreed to by the milk meter task group and that align with OIML tolerances.

8 NCWM 2021 Annual Meeting: Mr. Charlie Stutesman provided an update on the milk meter task group activities.
9 Mr. Stutesman noted that there was a field trip to observe milk metering systems. He noted that the proposed
10 tolerances will align the milk tolerances with the OIML tolerances for milk meters and Mr. Stutesman noted that the
11 OIML tolerances provides one tolerance for the meter and another tolerance for a milk metering system. He also
12 noted that it may be impractical to perform an air eliminator test on these devices due to comingling of product.

13 During the committees work session, the Committee agreed to a Voting Status for this item and added it to its voting
14 consent calendar.

15 During the voting session, Mr. Charlie Stutesman asked that consideration be given to adding a non-retroactive date
16 to the proposed tolerances. It was questioned during the discussion that if a non-retroactive date was added to the
17 tolerances, then, what tolerances would apply to existing meters that had been manufactured and tested prior to the
18 non-retroactive date. One of the concerns expressed with having a new tolerance table without a nonretroactive date
19 was whether or not existing devices would be required to be reevaluated in the NTEP. The conference voted against
20 adding the nonretroactive requirement to the proposed tolerance table and the item under consideration to change the
21 tolerances failed to receive the 27 votes from the House of State Representatives, so the item failed and went back to
22 the S&T committee. The S&T Committee agreed to a Developing status for this item.

23 **Note: For reference, the Item under Consideration that was included in the 2021 NCWM Interim Meeting**
24 **Agenda is provided below:**

Table 2.		
Tolerances for Vehicle-Mounted Milk Meters		
Indication (gallons)	Maintenance Tolerance (gallons)	Acceptance Tolerance (gallons)
100	0.5 <u>0.6</u>	0.3 <u>0.5</u>
200	0.7 <u>1.2</u>	0.4 <u>1.0</u>
300	0.9 <u>1.8</u>	0.5 <u>1.5</u>
400	1.1 <u>2.4</u>	0.6 <u>2.0</u>
500	1.3 <u>3.0</u>	0.7 <u>2.5</u>
Over 500	Add 0.002 <u>0.006</u> gallons per indicated gallon over 500	Add 0.001 <u>0.005</u> gallons per indicated gallon over 500

25 NCWM 2022 Interim Meeting: Mr. Charlie Stutesman (KS) spoke as chairperson of the Milk Meter Task Group. He
26 requested that this item be assigned back to the task group for further development. Mr. Stutesman provided an update
27 on the task group meeting in January 2022 in which they discussed tolerances in both 3.31 Vehicle Tank Meters and
28 3.35 Milk Meters and the need to have the tolerance be applied to both vehicle mounted and station meters as the
29 manufacturers are developing meters that will be capable of being installed in either application. The tolerance tables
30 can be found in the supporting documents. Mr. Stutesman also renewed the task groups request to expand its scope
31 to include possibly creating a new code that contains requirements of both vehicle mounted and stationary milk meters
32 and metering systems due to the unique properties of milk as a liquid. Speaking on behalf of himself, Mr. Stutesman
33 (KS) stated that he has provided a document in the supporting documents that outlines the four active and five inactive
34 NTEP certified meters and metering systems in terms of test draft size and applicable tolerances. He noted that the

1 active four have a range of 0.12%-0.6%. He also noted that milk meters are the only liquid measuring device where
 2 the volume tolerance decreases as the draft size increases and suggests percentages more in line with OIML tolerance
 3 would be more appropriate. Mr. Ken Ramsburg (MD) suggested combining the two tolerances to be used for field
 4 evaluations. Ms. Diane Lee (NIST OWM) commented that the task group should work toward making all test methods
 5 uniform. Mr. Doug Musick (KS) and Mr. Matt Douglas (CA) supported assigning this item to the task group for
 6 further development. During committee work sessions, the committee agreed to assign this item back to the milk
 7 meter task group so they may continue to ascertain data. In addition, the committee agreed to request that NCWM
 8 Chairman Ivan Hankins expand the scope of the task group to include all reference to milk meters, meter systems and
 9 related test methods, specifications and tolerance in an effort to harmonize the codes.

10 NCWM 2022 Annual Meeting: The Milk Meter Task Group Chair, Mr. Charles Stutesman (KS) provided an update
 11 on the task group's activity. Mr. Stutesman solicited comments and feedback from membership to continue efforts
 12 towards development. He also stated the task group is seeking a representative from the Western regional to serve on
 13 the task group and mentioned Mr. Aaron Yonkers of Colorado as a potential member. Mr. Stutesman mentioned he is
 14 intending to submit a request to the Committee to expand the task group's scope, including the gathering of all milk
 15 meter codes for consolidation into a single code.

16 **Regional Associations' Comments:**

17 WWMA 2021 Annual Meeting: Diane Lee (NIST OWM): put forth by task group working on milk meters. They're
 18 still in process of reviewing. It was put forth to vote but last-minute change to make it non retroactive. This put it back
 19 to developing. What would happen to devices that are currently in the field? During annual meeting this was returned
 20 back to developing and NIST supports developing.

21 The WWMA S&T Committee recommends the status remain Developmental. During the WWMA S&T Work Session
 22 Diane Lee (NIST OWM) was asked for further clarification on her testimony. She provided the following clarification:
 23 "During the Annual Meeting a proposal was made to add a non-retroactive date. Because questions were raised as to
 24 how this would affect existing devices the item was moved from Voting to Developing." The Committee looks
 25 forward to hearing from the working group.

26 SWMA 2021 Annual Meeting: No comments were received on this item. This committee would like to see more
 27 evidence and reasoning on why these devices should not have to meet the existing tolerances, and why the tolerances
 28 listed are appropriate.

29 This committee recommends the item remain Developing so that the submitters can gather more evidence about the
 30 accuracy of these devices.

31 CWMA 2022 Annual Meeting: Charlie Stutesman – KS, Chair of Milk Meter Tolerance Task Group (MMTTG) –
 32 Following 2022 NCWM Interim meeting, this item was sent back to the MMTTG. Moving forward with staying with
 33 original tolerances that were proposed. Request to expand scope has been submitted. There will be a MMTTG meeting
 34 prior to the July annual meeting. Hoping to move forward and elevate to voting status for next cycle.
 35

36 The CWMA S&T Committee recommends this item to remain an assigned item.

37 NEWMA 2022 Annual Meeting: Mr. Jim Willis (NY) commented as a member of the Milk Meter Task Group. He
 38 indicated that the task group has made strides and hopes for ability to perform additional work on the item.
 39

40 After hearing comments from the floor, the committee recognized the need for further development of the item and
 41 recommended that the item retain an assigned status. The committee recommends the NCWM Milk Meter Task Group
 42 continue to work with stakeholders to further develop this item.

43 Additional letters, presentation and data may have been submitted for consideration with this item. Please refer to
 44 www.ncwm.com/publication-15 to review these documents.

VTM-20.2

Regional recommendation to NCWM on item status:

- Recommend as a Voting Item on the NCWM agenda
- Recommend as an Information Item on the NCWM agenda
- Recommend as an Assigned Item on the NCWM agenda
(To be developed by an NCWM Task Group or Subcommittee)
- Recommend as a Developing Item on the NCWM agenda
(To be developed by source of the proposal)
- Recommend Withdrawal of the Item from the NCWM agenda
(In the case of new proposals, do not forward this item to NCWM)
- No recommendation from the region to NCWM
(If this is a new proposal, it will not be forwarded to the national committee by this region)

Comments and justification for the regional recommendation to NCWM: (This will appear in NCWM reports)

The following comments were received during the 2022 SWMA Annual Meeting:

Dr. Curran, State of Florida, stated he was concerned about increasing the tolerance for new technology.

No comments were received from the Milk Meter Tolerance Task Group.

The SWMA S&T Committee recommends this item remain as an Assigned Item.

1

2

LPG – LIQUIFIED PETROLEUM GAS AND ANHYDROUS AMMONIA LIQUID-MEASURING DEVICES

3

4

LPG-22.3 D *S.2.5. Zero-Set-Back Interlock., S.2.5.2. Zero -Set-Back Interlock for Stationary Customer -Operated Electronic Retail Motor-Fuel Devices.*

5

6

Source:

National Propane Gas Association and U-Haul International, Inc.

8

Purpose:

The proposal will address practical issues that propane marketers encounter when trying to comply with the zero-set-back requirements for propane stationary and truck-mounted meters in Handbook 44.

10

11

Item Under Consideration:

Amend Handbook 44, Liquefied Petroleum Gas and Anhydrous Ammonia Liquid-Measuring Devices Code as follows:

13

14

S.2.5. Zero-Set-Back Interlock.

15

S.2.5.1. Zero-Set-Back Interlock, Electronic Stationary Meters (Other than Stationary Retail Motor-Fuel Dispensers) and Electronic Vehicle-Mounted Meters. – A device shall be constructed so that after an individual delivery or multiple deliveries at one location have been completed, an automatic interlock system shall engage to prevent a subsequent delivery until the indicating element and, if equipped, recording element have been returned to their zero positions.

16

17

18

19

20

[Nonretroactive as January 1, 2021]

21

(Added 2019)

22

(Amended 2021)

23

1 **S.2.5.2. Zero-Set-Back Interlock for Stationary Customer-Operated Electronic Retail Motor-Fuel Devices. – A**
 2 *device shall be constructed so that:*

3 *(a) after a delivery cycle has been completed by moving the starting lever to any position that shuts off the*
 4 *device, an automatic interlock prevents a subsequent delivery until the indicating elements and recording*
 5 *elements, if the device is equipped and activated to record, have been returned to their zero positions;*

6 *(b) the discharge nozzle cannot be returned to its designed hanging position (that is, any position where the*
 7 *tip of the nozzle is placed in its designed receptacle and the lock can be inserted) until the starting lever is in*
 8 *its designed shut-off position and the zero-set-back interlock has been engaged; and*

9 *(c) in a system with more than one dispenser supplied by a single pump, an effective automatic control valve*
 10 *in each dispenser prevents product from being delivered until the indicating elements on that dispenser are*
 11 *in a correct zero position.*

12 *[Nonretroactive as of January 1, 2017]*

13 *(Added 2016)*

14 **Previous Action:**

15 2022: Developing

16 **Original Justification:**

17 National Propane Gas Association:

18 This proposal was developed by the National Propane Gas Association’s Technology, Standards and Safety
 19 Committee, a volunteer organization comprised of 2500+ members, including propane retail marketers and others
 20 providing products or services to the propane industry.

21 In S.2.5, the removal of the vehicle mounted meters from this two-minute requirement is necessary as the initiation of
 22 a vehicle mounted meter is performed at the truck prior to moving the delivery hose to the customer tank, sometimes
 23 as far as 150 feet from the meter, or in installations with multiple containers that may require continued adjustment of
 24 containers or delivery hose to complete a delivery. This configuration can lead to periods of up to 5 minutes between
 25 initial meter engagement and first container filling or between containers being filled on a single delivery.

26 In revised S.2.6, we are proposing that vehicle mounted meters be allowed periods between meter engagement and
 27 product flow of greater than 2 minutes prior to automated time out initiation. A five-minute period is more practical
 28 as the initiation of a vehicle mounted meter is performed at the truck prior to moving the delivery hose to the customer
 29 tank, sometimes as far as 150 feet from the meter, or in installations with multiple containers that may require
 30 continued adjustment of containers or delivery hose to complete a delivery. The configuration on a typical bobtail can
 31 lead to periods of up to 5 minutes between initial meter engagement and first container filling or additionally periods
 32 of greater than two minutes can transpire between containers being filled on a single delivery.

33 Addressing proposed new S.2.7, motor fuel, within the context of NFPA 58, refers to any container that has the
 34 potential to provide propane to fuel an engine. This can include a multitude of DOT cylinders and ASME containers
 35 that are not for the propulsion of an automobile. Current mechanical meter technology utilized in a standard propane
 36 dispenser for the filling of portable containers, such as those utilized in NFPA 58 for motor fuel applications or those
 37 that do power automobiles, are not capable of being equipped with a zero-set-back interlock and the technology will
 38 not be potentially available until 2022, per meter manufacturers.

39 NFPA 58 does not currently explicitly allow the public to refuel its automobiles. All automobiles or other containers
 40 must be filled by a specially trained employee. A proposed change has been introduced for consideration in the 2023
 41 edition of NFPA 58 that would permit public refueling of automobiles as long as the dispensing system meets very
 42 specific safety requirements, including a specialized nozzle, and is furnished with visible instructions. Upon the
 43 acceptance of this new public refueling allowance the propane industry agrees that Zero-Setback-interlocks are
 44 needed. These public self-service automotive dispensing systems will be listed to Underwriters Laboratories Standard
 45 495 and will be dedicated to the filling of motor vehicles.

1 In view of the above information, existing dispenser systems that may only be utilized by qualified trained employees
2 should be permitted to continue operations with the existing meter technology and should not be required to include
3 Zero-Set-Back Interlocks. This should include when the dispenser is removed from one location and installed in
4 another, as long as the original meter remains functional. Existing cabinetry and controls utilized in a standard
5 dispenser cabinet generally include non-digital meters and no electronic controls with the exception of a single switch
6 that operates the pump. These simplistic designs are still effective and should not be prohibited from use in future
7 (new) installations in which the transfer process is attended by trained personnel. Limiting the scope of this section
8 will allow attended dispenser operations which are primarily utilized for filling of portable containers to remain
9 consistent in design and construction. Current use of this technology has not resulted in any known impact to the
10 consumer or over-charge situations. The term “self-operated” is used in other locations in Handbook 44 and would
11 include electronic dispensing devices and meters, which would then be consistent with the prior two sections that are
12 limited to electronic meters.

13 It is difficult to counter the arguments above. The sheer difficulties that a service person can encounter when a wet
14 hose must be carried over terrain fairly long distances between receiving containers should be sufficient justification
15 to approve this proposal. The counter argument to new S.2.7 would be that the customer may not be able to view the
16 meter to ensure it is set back to zero. The submitter requested that this be a Voting Item in 2022.

17 U-Haul International, Inc.

18 Motor fuel, within the context of NFPA 58, refers to any container that has the potential to provide propane to fuel an
19 engine. This can include a multitude of DOT cylinders and ASME containers that are not for the propulsion of an
20 automobile. Current mechanical meter technology utilized in a standard propane dispenser for the filling of portable
21 containers, such as those utilized in NFPA 58 for motor fuel applications or those that do power automobiles, are not
22 capable of being equipped with a zero-set-back interlock and the technology will not be potentially available until
23 2022, per meter manufacturers.

24 NFPA 58 currently does not allow the public to refuel its automobiles. All automobiles or other containers must be
25 filled by a specially trained employee. A proposed change has been introduced for consideration in the 2023 edition
26 of NFPA 58 that would permit public refueling of automobiles as long as the dispensing system meets very specific
27 safety requirements, including a specialized nozzle, and is furnished with visible instructions. Upon the acceptance of
28 this new public refueling allowance the propane industry agrees that Zero-Setback-interlocks are needed. These public
29 self-service automotive dispensing systems will be listed to Underwriters Laboratories Standard 495 and will be
30 dedicated to the filling of motor vehicles.

31 Most propane dispensed is for purposes other than motor-fuel. Pursuant to NFPA 58, this is accomplished by a trained
32 and certified employee dispensing propane, typically using mechanical meters, into cylinders and tanks. The
33 employee is trained and required to manually reset the meter to zero after each transaction and verify the meter is reset
34 prior to initiating a subsequent transaction. This has been and remains an accepted practice for dispensing
35 propane. This process is the industry standard for approximately 97% of all propane used in the United States. See
36 U.S. Department of Energy, Alternative Fuels Data Center afdc.energy.gov/fuels/propane_basics.html.

37 Unlike traditional motor-fuel, such as gasoline or diesel, customers cannot currently dispense propane into their
38 vehicles. If NFPA 58 is amended to allow customers to dispense their own propane into their vehicles and the demand
39 for propane as motor-fuel increases, the market will drive retailers to provide electronic customer-operated retail
40 motor-fuel devices to meet the demand and customer expectations for efficient and expedient fueling transactions. At
41 that time, the electronic customer-operated motor-fuel devices will certainly need to incorporate an automatic zero-
42 set-back interlock. It is simply too early in the process to effectively force mechanical retail motor-fuel devices out
43 of the market for such a small percentage of the retail propane market (approximately 3%).

44 **Comments in Favor:**

45 **Regulatory:**

- 46 • Several regulators voiced support for this item, including adding the 5 minute timeout to each section.

47 **Industry:**

- 1 • After hearing comments from the floor, the submitter understands that modifications must be made to
2 the item, in terms of numbering, to line up with the 2022 version of the handbook. The submitter also
3 now feels that a 2-minute time out may be unattainable and believes a 5 minute timeout would be
4 appropriate in each section.

5 **Advisory:**

- 6 •

7 **Comments Against:**

8 **Regulatory:**

- 9 • A regulator voiced concern with the intent and indicated that aspects of this proposal are also included
10 in LPG-22.2 and he is opposed to item, except for the 5- minute timeout being applied.

11 **Industry:**

- 12 •

13 **Advisory:**

- 14 •

15 **Neutral Comments:**

16 **Regulatory:**

- 17 •

18 **Industry:**

- 19 •

20 **Advisory:**

- 21 • NIST OWM pointed to new numbering in the 2022 version of the handbook and suggested that the
22 item under consideration be renumbered for accuracy. NIST OWM also noted that the automatic
23 timeout is currently 3 minutes in most other specifications and urged the committee to consider if it is
24 necessary in other applications.

25 **Item Development:**

26 NCWM 2022 Interim Meeting: During the committee work session, the committee reviewed a document that was
27 provided by the submitter with updated language and paragraph numbering, however, members of the committee
28 concluded the proposal was still not fully developed. The committee agreed to amend the proposal as requested by
29 the submitter. The committee recommended the submitter of this item work with the submitter of LPG-22.2 to
30 harmonize the two proposals.

31 Following the 2022 Interim Meeting, the submitters of this item and Item LPG-22.2 collaborated on a joint proposal
32 as requested. For this reason, the Committee withdrew Item LPG-22.2. See the Item under Consideration for the new
33 joint proposal.

34 For more information or to provide comment, please contact:

35 Bruce Swiecicki
36 National Propane Gas Association
37 815-806-9035m bswiecicki@npga.org

38 And

1 Konrad Pilatowicz
2 U-Haul International, Inc.
3 konrad_pilatowicz@uhaul.com

4 NCWM 2022 Annual Meeting: The Committee received an update from the submitters that they oppose the item as
5 currently written. The submitters explained that LPG should be dispensed by a trained individual and not “customer
6 operated” and the adaptability for mechanical equipment is not cost effective. The submitters do not see the need for
7 separate requirement for vehicle fueling and bottle filling as the devices can do both and LPG motor fuel is only 3%
8 of the market, therefore emphasis should be placed on the predominant function. After the 2022 Interim Meeting, the
9 Committee received an updated document from the submitters, and the Committee used that document as the current
10 item under consideration. If the submitters are opposed to the item under consideration as written, the Committee as
11 they submit updated language to the regions for further consideration. The Committee has agreed to keep this item as
12 a Developing item.

13 **Regional Associations’ Comments:**

14 WWMA 2021 Annual Meeting: Bruce Swiecicki (National Propane Gas Association): This addresses two subjects:
15 has to do with zero setback, but were breaking out vehicle meters. In some situations with a bobtail where there may
16 be several tanks not close to one another and the operator has to carry the long hose.. They have to walk from tank to
17 tank. They want more time (5-minute timer). He supports this but wants to break out the systems that aren’t used full
18 time for Retail motor fuel. Dwight Farr (U-Haul Program Manager): they are in support of the NPGA proposal. Tina
19 Butcher (NIST OWM): Look at the previous verbiage. The Conference did vote on changes with regard to zero setback
20 and time out in 2021. The paragraph number is different than the 2020 version.

21 The WWMA S&T Committee recommends based on testimony heard in open hearings and input from the NIST
22 advisors during the work session that this item be assigned a Developing status. The Committee also recommends
23 that the submitters of LPG-22.2 and LPG-22.3 combine their efforts to develop one of the items with consideration to
24 the 2022 version of NIST HB44.

25 SWMA 2021 Annual Meeting: Steve Benjamin, North Carolina, supports this item. This committee recommends
26 this item move forward as a Voting item.

27 CWMA 2022 Annual Meeting: Konrad Pilatowicz – U-Haul International – (submitted comments via email prior to
28 meeting) This proposal was developed by the National Propane Gas Association’s Technology, Standards and Safety
29 Committee, a volunteer organization comprised of 2500+ members, including propane retail marketers and others
30 providing products or services to the propane industry.

31 Addressing proposed S.2.5.2, motor fuel, within the context of NFPA 58, refers to any container that has the potential
32 to provide propane to fuel an engine. This can include a multitude of DOT cylinders and ASME containers that are
33 not for the propulsion of an automobile. Current mechanical meter technology utilized in a standard propane dispenser
34 for the filling of portable containers, such as those utilized in NFPA 58 for motor fuel applications or those that do
35 power automobiles, are not capable of being equipped with a zero-set-back interlock and the technology will not be
36 potentially available until 2022, per meter manufacturers.

37 NFPA 58 does not currently explicitly allow the public to refuel its automobiles. All automobiles or other containers
38 must be filled by a specially trained employee. A proposed change has been introduced for consideration in the 2023
39 20 edition of NFPA 58 that would permit public refueling of automobiles as long as the dispensing system meets
40 specific safety requirements, including a specialized nozzle, and is furnished with visible instructions. Upon the
41 acceptance of this new public refueling allowance the propane industry agrees that Zero-Setback-interlocks are
42 needed. These public self-service automotive dispensing systems will be listed to Underwriters Laboratories Standard
43 495 and will be dedicated to the filling of motor vehicles.

44 In view of the above information, existing dispenser systems with mechanical registers that may only be utilized by
45 qualified trained employees should be permitted to continue operations with the existing meter technology and should
46 not be required to include Zero-Set-Back Interlocks. This should include when the dispenser is removed from one
47 location and installed in another, as long as the original meter remains functional. Existing cabinetry and controls

1 utilized in a standard dispenser cabinet generally include non-digital meters and no electronic controls with the
 2 exception of a single switch that operates the pump. These simplistic designs are still effective and should not be
 3 prohibited from use in future (new) installations in which the transfer process is attended by trained personnel.
 4 Limiting the scope of this section will allow attended dispenser operations which are primarily utilized for filling of
 5 portable containers to remain consistent in design and construction. Current use of this technology has not resulted in
 6 any known impact to the consumer or over-charge situations. The term “customer-operated” is used in several other
 7 locations in Handbook 44.

8
 9 Michael Keilty – Endress+Hauser – NTEP Measuring Sector – This is a new item that the NTEP Measuring Sector
 10 has not reviewed and would like to discuss at their September 2022 meeting.

11
 12 The CWMA S&T Committee recommends this moves forward as a voting item.

13 NEWMA 2022 Annual Meeting: No comments were heard from the body on this item.

14 Additional letters, presentation and data may have been submitted for consideration with this item. Please refer to
 15 www.ncwm.com/publication-15 to review these documents.

LPG-22.3
<p>Regional recommendation to NCWM on item status:</p> <p><input type="checkbox"/> Recommend as a Voting Item on the NCWM agenda</p> <p><input type="checkbox"/> Recommend as an Information Item on the NCWM agenda</p> <p><input type="checkbox"/> Recommend as an Assigned Item on the NCWM agenda <i>(To be developed by an NCWM Task Group or Subcommittee)</i></p> <p><input type="checkbox"/> Recommend as a Developing Item on the NCWM agenda <i>(To be developed by source of the proposal)</i></p> <p><input checked="" type="checkbox"/> Recommend Withdrawal of the Item from the NCWM agenda <i>(In the case of new proposals, do not forward this item to NCWM)</i></p> <p><input type="checkbox"/> No recommendation from the region to NCWM <i>(If this is a new proposal, it will not be forwarded to the national committee by this region)</i></p>
<p>Comments and justification for the regional recommendation to NCWM: <i>(This will appear in NCWM reports)</i></p> <p>No comments were received on this item during the 2022 SWMA Annual Meeting.</p> <p>This item has been replaced with LPG 23.1.</p> <p>The SWMA S&T Committee recommends this item be Withdrawn.</p>

16

17 **LPG-23.1 S.2.5. Zero-Set-Back Interlock**

18 **Source:**
 19 National Propane Gas Association and U-Haul International

20 **Purpose:**
 21 Address practical issues that propane retailers encounter when trying to comply with the zero setback requirements
 22 for propane stationary meters in Handbook 44.

23 **Item under Consideration:**
 24 Amend Handbook 44, Liquefied Petroleum Gas and Anhydrous Ammonia Liquid-Measuring Devices Code as
 25 follows:

1 **S.2.5. Zero-Set-Back Interlock.**
2

3 **S.2.5.1. Zero-Set-Back Interlock, Electronic Stationary Meters (Other than Devices used Exclusively as**
4 **Stationary Retail Motor- Fuel Dispensers) and Electronic Vehicle-Mounted Meters. – A device shall be**
5 *constructed so that after an individual delivery or multiple deliveries at one location have been completed,*
6 *an automatic interlock system shall engage to prevent a subsequent delivery until the indicating element and,*
7 *if equipped, recording element have been returned to their zero positions.*

8 *[Nonretroactive as January 1, 2021]*
9 (Added 2019) (Amended 2021)

10 **S.2.5.2. Zero-Set-Back Interlock for Devices Used Exclusively as Stationary Retail Motor-**
11 **Fuel Devices. – A device shall be constructed so that:**
12

13 *(a) after a delivery cycle has been completed by moving the starting lever to any position that shuts off the*
14 *device, an automatic interlock prevents a subsequent delivery until the indicating elements and recording*
15 *elements, if the device is equipped and activated to record, have been returned to their zero positions;*

16
17 *(b) the discharge nozzle cannot be returned to its designed hanging position (that is, any position where the*
18 *tip of the nozzle is placed in its designed receptacle and the lock can be inserted) until the starting lever is in*
19 *its designed shut-off position and the zero-set-back interlock has been engaged; and*

20
21 *(c) in a system with more than one dispenser supplied by a single pump, an effective automatic control valve*
22 *in each dispenser prevents product from being delivered until the indicating elements on that dispenser are*
23 *in a correct zero position.*

24 *[Nonretroactive as of January 1, 2017]*
25 (Added 2016)

26 **Previous Action:**

27 New item in 2023

28 **Original Justification:**

29 This proposal reflects the intent of U-Haul International, Inc. and the National Propane Gas Association’s Technology,
30 Standards and Safety Committee, a volunteer organization comprised of 2500+ members, including propane retail
31 marketers and others providing products or services to the propane industry.

32 The intent behind enacting the current version of S.2.5.2 was to create consistency among motor-fuel devices used for
33 all products. This proposal strikes a balance between a consistent standard for retail motor-fuel devices and the diverse
34 applications and industry standard for dispensing LP-Gas. To that end, this proposal addresses only those devices
35 used exclusively for retail motor-fuel transfer. Multi-use LP-Gas devices that are used for the filling motor-fuel and
36 other containers, including grill cylinders, forklift cylinders, cylinders used on recreational vehicles and even motor
37 fuel containers, are covered by S.2.5.1.

38
39 Most LP-Gas dispensed is for purposes other than motor-fuel. (Less than 3% of all LP-Gas used in the United States
40 is used for transportation. See U.S. Department of Energy, Alternative Fuels Data Center
41 afdc.energy.gov/fuels/propane_basics.html.) Pursuant to NFPA 58, this is accomplished by a trained and certified
42 employee dispensing LP-Gas, typically using analog (mechanical) meters, into cylinders and tanks. The analog
43 (mechanical) meters are safe and effective, and most notably exempt from the zero-set-back requirement because
44 S.2.5.1 only applies to electronic devices. Clearly, Handbook 44 recognizes this reality as S.2.5.1 does not require that
45 all LP-Gas dispensers have zero-set-back interlocks, only electronic devices. S.2.5.1 is most appropriate because
46 currently there is no readily available technology that can be used to retrofit an analog device. When looked at from
47 a cost/benefit perspective, one has to question the expense of replacing an analog device with an electronic device at
48 a location that mostly serves portable cylinders and not motor vehicle tanks when LP-Gas’s use is so limited in
49 transportation.

1
2 Furthermore, NFPA 58 currently does not allow the public to refuel its LP-Gas powered motor vehicles. All motor
3 vehicles or other containers must be filled by a specially trained employee. A proposed change has been introduced
4 for consideration in the 2023 edition of NFPA 58 that would permit public refueling of motor vehicles as long as the
5 dispensing system meets very specific safety requirements, including a specialized nozzle, and is furnished with visible
6 instructions. Upon the acceptance of this new public refueling allowance, the LP-Gas industry agrees that Zero-
7 Setback-interlocks are needed. These public, self-service motor vehicle dispensing systems will be listed to
8 Underwriters Laboratories Standard 495 and will be dedicated to the filling of motor vehicles.

9
10 For the minimal amount of retail motor fuel customers that a typical LP-Gas dispenser serves, both U-Haul and NPGA
11 feel that this proposal represents the most equitable approach to date for balancing the need to ensure fair transactions
12 and consistent standards with how the LP-Gas industry currently dispenses LP-Gas and LP-Gas's future transportation
13 applications as envisioned by the proposed changes to NFPA 58 without conducting costly industry-wide retrofits of
14 existing, functioning multi-use equipment. Handbook 44 needs to work with industry to make technical standards
15 economically feasible lest it risk the advancement of LP-Gas as a viable and clean motor-fuel.

16 One continually occurring objection is that there would be no protection for the consumer without a zero-set-back
17 feature on retail motor fuel devices. That really isn't the case, however, as the customer always has the option to check
18 the dispenser and meter before the filling process begins to verify that it is starting at zero.

19 The submitter requested that this be a Voting item.

20 **Comments in Favor:**

21 **Regulatory:**

- 22 •

23 **Industry:**

- 24 •

25 **Advisory:**

- 26 •

27 **Comments Against:**

28 **Regulatory:**

- 29 •

30 **Industry:**

- 31 •

32 **Advisory:**

- 33 •

34 **Neutral Comments:**

35 **Regulatory:**

- 36 •

37 **Industry:**

- 38 •

39 **Advisory:**

1 •

2 **Item Development:**

3 New

4 Additional letters, presentation and data may have been submitted for consideration with this item. Please refer to
5 www.ncwm.com/publication-15 to review these documents.

LPG-23.1
<p>Regional recommendation to NCWM on item status:</p> <p><input checked="" type="checkbox"/> Recommend as a Voting Item on the NCWM agenda <input type="checkbox"/> Recommend as an Information Item on the NCWM agenda <input type="checkbox"/> Recommend as an Assigned Item on the NCWM agenda <i>(To be developed by an NCWM Task Group or Subcommittee)</i> <input type="checkbox"/> Recommend as a Developing Item on the NCWM agenda <i>(To be developed by source of the proposal)</i> <input type="checkbox"/> Recommend Withdrawal of the Item from the NCWM agenda <i>(In the case of new proposals, do not forward this item to NCWM)</i> <input type="checkbox"/> No recommendation from the region to NCWM <i>(If this is a new proposal, it will not be forwarded to the national committee by this region)</i></p>
<p>Comments and justification for the regional recommendation to NCWM: <i>(This will appear in NCWM reports)</i></p> <p>No comments were received on this item during the 2022 SWMA Annual Meeting.</p> <p>The SWMA S&T Committee recommends this item move forward as a Voting Item.</p>

6

7 **LPG-23.2 S.2.6. Automatic Timeout.**

8
9 **Source:**

10 National Propane Gas Association

11 **Purpose:**

12 Address practical issues that propane marketers encounter when trying to comply with the zero setback requirements
13 for propane stationary and truck-mounted meters in Handbook 44.

14 **Item under Consideration:**

15 Amend Handbook 44, LPG and Anhydrous Ammonia Liquid-Measuring Devices as follows:

16 ***S.2.6. Automatic Timeout.***

17 ***S.2.6.1. Electronic Stationary (Other than Stationary Retail Motor-Fuel Dispensers) and ~~Electronic~~***
18 ***~~Vehicle-Mounted Meters.~~*** – For individual deliveries, if there is no product flow for three minutes the
19 *transaction must be completed before additional product flow is allowed. The three-minute timeout shall be*
20 *a sealable feature on an indicator.*
21 *[Nonretroactive as of January 1, 2021]*
22 *(Added 2021) (**Amended 20XX**)*

23
24 ***S.2.6.2. Automatic Timeout Pay-at-Pump Retail Motor-Fuel Devices*** – Once a device has been
25 *authorized, it must deauthorize within three minutes if not activated. Reauthorization of the device must be*
26 *performed before any product can be dispensed. If the time limit to deauthorize the device is*
27 *programmable, it shall not accept an entry greater than three minutes.*

1 *[Nonretroactive as of January 1, 2022]*
2 (Added 2021)

3
4 **S.2.6.3. Electronic Vehicle-Mounted Meters. – For individual deliveries, if there is no product flow for**
5 **five minutes the transaction must be completed before additional product flow is allowed. The five-**
6 **minute timeout shall be a sealable feature on an indicator.**
7 **(Added 20XX)**

8 **Previous Action:**
9 New Item in 2023

10 **Original Justification:**

11 This proposal was developed by the National Propane Gas Association’s Technology, Standards and Safety
12 Committee, a volunteer organization comprised of 2500+ members, including propane retail marketers and others
13 providing products or services to the propane industry.

14
15 In S.2.6.1, the removal of the vehicle mounted meters from this three-minute requirement is necessary as the initiation
16 of a vehicle mounted meter is performed at the truck prior to moving the delivery hose to the customer tank, sometimes
17 as far as 150 feet from the meter, or in installations with multiple containers that may require continued adjustment of
18 containers or delivery hose to complete a delivery. This configuration can lead to periods of up to 5 minutes between
19 initial meter engagement and first container filling or between containers being filled on a single delivery.

20
21 In revised S.2.6, we are proposing that vehicle mounted meters be allowed periods between meter engagement and
22 product flow of greater than 2 minutes prior to automated time out initiation. A five-minute period is more practical
23 as the initiation of a vehicle mounted meter is performed at the truck prior to moving the delivery hose to the customer
24 tank, sometimes as far as 150 feet from the meter, or in installations with multiple containers that may require
25 continued adjustments of containers or delivery hose to complete a delivery. The configuration on a typical bobtail
26 can lead to periods of up to 5 minutes between initial meter engagement and first container filling or additionally
27 periods of greater than two minutes can transpire between containers being filled on a single delivery.

28 The submitter acknowledged that the opposition may feel that the change enacted from two to three minutes for the
29 timeout is sufficient. However, it is not. Some sources say the average age of drivers in the propane industry is mid-
30 50’s. Those folks do not move as quickly or nimbly as much younger drivers.

31 The submitter requested that this be a Voting item.

32 **Comments in Favor:**

33 **Regulatory:**
34 •

35 **Industry:**
36 •

37 **Advisory:**
38 •

39 **Comments Against:**

40 **Regulatory:**
41 •

42 **Industry:**
43 •

1 **Advisory:**

- 2 •

3 **Neutral Comments:**

4 **Regulatory:**

- 5 •

6 **Industry:**

- 7 •

8 **Advisory:**

- 9 •

10 **Item Development:**

11 New

12 Additional letters, presentation and data may have been submitted for consideration with this item. Please refer to
13 www.newm.com/publication-15 to review these documents.

LPG-23.2
Regional recommendation to NCWM on item status:
<input checked="" type="checkbox"/> Recommend as a Voting Item on the NCWM agenda <input type="checkbox"/> Recommend as an Information Item on the NCWM agenda <input type="checkbox"/> Recommend as an Assigned Item on the NCWM agenda <i>(To be developed by an NCWM Task Group or Subcommittee)</i> <input type="checkbox"/> Recommend as a Developing Item on the NCWM agenda <i>(To be developed by source of the proposal)</i> <input type="checkbox"/> Recommend Withdrawal of the Item from the NCWM agenda <i>(In the case of new proposals, do not forward this item to NCWM)</i> <input type="checkbox"/> No recommendation from the region to NCWM <i>(If this is a new proposal, it will not be forwarded to the national committee by this region)</i>
Comments and justification for the regional recommendation to NCWM: (This will appear in NCWM reports)
No comments were received on this item during the 2022 SWMA Annual Meeting.
The SWMA S&T Committee recommends this item move forward as a Voting Item.

14

15 **LPG-15.1 D N.3. Test Drafts.**

16 **Previously LPG-4**

17 *Note: In 2019 this item was combined with Block 1 “Terminology For Testing Standards” and other items that*
18 *addressed terminology for standards and the use of “master meters.” Based on comments heard during the 2021*
19 *Annual Meeting, the S&T Committee recommended that all items that were combined with Block 1 “Terminology For*
20 *Testing Standards” that originally appeared as a separate item or a separate block of items on the S&T agenda prior*
21 *to 2019, be removed from Block 1 “Terminology For Testing Standards” and appear as originally presented.*
22 *Item LPG-15.1 was removed from Block 1 “Terminology For Testing Standards” and now appears as a separate item*
23 *on the 2022 Interim Meeting agenda.*

24

25 **Source:**

26 Endress + Hauser Flowtec AG USA

1
2
3
4
5
6
7
8
9
10
11
12
13
14
15
16
17
18
19
20
21
22
23
24
25
26
27
28
29
30
31
32
33
34
35
36
37
38
39
40
41
42
43
44

Purpose:

Amend Handbook 44 to allow field reference standards meters to be used to test and place into service dispensers and delivery system flow meters.

Item Under Consideration:

Amend Handbook 44, LPG and Anhydrous Ammonia Liquid-Measuring Devices as follows:

N.3. Test Drafts.

N.3.1 Minimum Test - Test drafts should be equal to at least the amount delivered by the device in 1 minute at its normal discharge rate.
(Amended 1982)

N.3.2. Field Reference Standard Meter Test. – The minimum quantity for any test draft shall be equal to or greater than the amount delivered in one minute at the flow rate being tested.
(Added 20XX)

Background and Discussion:

This item has been assigned to the submitter for further development. For more information or to provide comment, please contact:

Mr. Michael Keilty
Endress + Hauser Flowtec AG
970-586-2122, michael.keilty@us.endress.com

The use of transfer standards is recognized in Code sections 3.34 Cryogenic Liquid-Measuring Devices Code and 3.38 Carbon Dioxide Liquid-Measuring Devices Code and 3.39 Hydrogen Gas-Measuring Devices – Tentative Code. Transfer standard is only defined for testing cryogenic liquid measuring devices. It has been pointed out that the term transfer standard is not correct and that field reference standard meters may be more appropriate. See new the item under consideration, updated on September 8, 2017.

Field evaluation of LPG meters and CNG dispensers and LNG dispensers is very difficult using volumetric and gravimetric field standards and methods. The tolerances for these applications are such that using field reference standard meters are more efficient and safer. With CNG and LNG and LPG applications, the field reference standard meters are placed in-line with the delivery system as it is used to fill tanks and vehicles. The use of field reference standard meters eliminates return to storage issues. The use of field reference standard meters is easier and faster compared to the use of traditional field standards. The cost of using field reference standard meters and transporting them is much less than the cost of traditional field provers and standards.

Recognition in Handbook 44 will enable States to allow field reference standard meters to place systems into service and for field enforcement.

Volumetric field provers and gravimetric field proving are susceptible to environmental influences. The State of Colorado uses a field reference standard meter to test propane delivery truck meters. The State of Nebraska has used a field reference standard meter to test agricultural chemical meters. Other States have asked that there be recognition in HB44 in order for their State to allow the use of field reference standard meters.

In some applications, field reference standard meters are not more accurate than the meters used in the application. For that reason, longer test drafts and possibly more tests may need to be run.

The State of California is purported to have conducted a short study of field reference standard meters in the past. The conclusion did not lead to wide adoption of the practice.

1 Section 3.37 Mass Flow Meters user requirement U.R.3.8. Return of Product to Storage, Retail Compressed Natural
2 Gas Dispensers requires that the natural gas which is delivered into the test container must be returned to storage. This
3 is difficult and most often not complied with when the test vessel contents are released to atmosphere. States often
4 have difficulties in remote locations finding suitable field reference equipment.

5 The Committee initially considered a proposal to modify paragraph N.3. Test Drafts and to add a new paragraph N.3.2.
6 Transfer Standard Test as shown below. Note that, in Fall 2016, Mr. Keilty provided an update to this proposal as
7 shown in the Item Under Consideration above.

8 **N.3. Test Drafts. –**
9

10 **N.3.1 Minimum Test** - Test drafts should be equal to at least the amount delivered by the device in one
11 minute at its normal discharge rate.

12 (Amended 1982)

13
14 **N.3.2. Transfer Standard Test. – When comparing a meter with a calibrated transfer standard, the**
15 **test draft shall be equal to at least the amount delivered by the device in 2 minutes at its maximum**
16 **discharge rate.**

17 The submitter recommended that NIST update EPO 28 for CNG dispensers and EPO 26 for LPG Liquid Measuring
18 Systems to include transfer standard meter tests. NIST Handbook 105-4 should also be revised to specifically address
19 the transfer standard meter and the requirements for use.

20 The S&T Committee might also consider amending Sections 3.30 Liquid-Measuring Devices Code and 3.31 Vehicle-
21 Tank Meters Code to allow transfer standard meters.

22 The Committee received written comments on all items in Block 4 and Block 5, as well as LPG-4 and MFM-2
23 emphasizing the need for there to be more study and discussion of the issues to assess the ramifications of all the
24 proposed changes. The Committee also received written comments from the SMA that it looks forward to further
25 information on these items and stating that it is important to be consistent in our use of terms across multiple sections
26 of NIST Handbook 44. The Committee agreed to carryover this group of items on its 2019 agenda to allow for further
27 discussion and development of these proposals.

28 NCWM 2019 Interim Meeting: The S&T Committee decided to combine the items on the agenda dealing with the
29 issue of transfer standard (including items already combined into blocks) into one block. Block 1 (New) of the Interim
30 Meeting report now includes Gen-3, Block 1 (original items from the 2019 interim agenda that appeared under Block
31 1), Block 2, LPG-3 and MFM-5, which were all separate items and blocks of items on the S&T Committee's 2019
32 Interim Meeting agenda (NCWM Publication 15). Agenda items Gen-3, Block 1, Block 2, LPG-3, and MFM-5 are
33 listed separately on the Interim agenda with a note added beneath each individual item referring the reader to the New
34 B1 items. All items under this New B1 have retained the same numbering system for ease in referring to the appendix
35 for discussion on each item.

36 2019 NCWM Annual Meeting: Mr. Brett Gurney (NCWM Chairman) commented regarding the formation of a Task
37 Group assigned to further develop this block proposal. The TG is charged with providing definitions for various types
38 of standards (transfer, field, reference, etc.) as well as the criteria to be met by these types of standards. The completion
39 date given to the TG is July 2021. The Committee agreed to the Assigned status for this block of items and looks
40 forward to hearing updates from the TG. the Chair of the task group was:

41 Mr. Jason Glass
42 Kentucky Department of Agriculture
43 502-573-0282, jason.glass@ky.gov

44 NCWM 2020 Interim Meeting: Field Standard TG Chair Jason reported that the Task Group met prior to the Interim
45 meeting and has begun discussion of the items under Block 1. Mr. Glass stated that bi-weekly teleconference meetings
46 were scheduled and that the group was optimistic but had significant work to accomplish.

1 Mr. Russ Vires (SMA) supports the Scale item, SCL 18.1; in this block, Mr. Dimitri Karimov (Meter Manufacturers
2 Association) supports the Task Group activities, Ms. Tina Butcher (NIST OWM) was encouraged with the progress
3 on terminology and provided an update on the Mass Flow Meter testing reporting that field testing was conducted
4 October 28 to November 1, 2019 and that State and Industry participation included Colorado, Florida, Oregon,
5 Emerson, and Tulsa Gas Technology.

6 Mr. Kurt Floren (Los Angeles Co., CA) raised concerns with GEN-19.1. regarding the definition of “Standard, Field”
7 and its reference to “stable” standards and how long a standard is expected to be stable, which is typically 1-year, for
8 which he believes should be longer. Mr. Floren also questioned the statement in the definition “tested over a range of
9 environmental and operational conditions that the measuring devices is used...” Mr. Floren noted that he was unsure
10 if all laboratories will have the capabilities to test over this wide range of conditions. Mr. Floren also expressed
11 concerns with the definition “Standard, Transfer” citing that this standard may not meet the fundamental
12 considerations requirement for standards over a long period of time or wide range of environmental conditions.

13 Mr. Steve Harrington (OR) echoed Mr. Floren’s comments. Field Standard TG Chair Glass responded that these are
14 concerns of the TG and these issues will be discussed and considered as the TG develops these items.

15 During the Committee’s work session, the Committee agreed that this item should remain an Assigned item.

16 NCWM 2021 Interim Meeting: NCWM Field Standard TG Chair, Mr. Jason Glass (KY) provided an update on the
17 Task Group activities. Mr. Glass reported that the field standard Task Group is following the activities of the NIST
18 Master Meter Project and that the Task Group reviewed API specifications for use of master meters as a standard and
19 a test protocol that will be used to ensure uniformity in collecting data on master meters used as field standards. He
20 also reported that the TG does not have a recommendation for this item. Mr. Glass also reported that he would be
21 stepping down as the TG Chair. Mr. Mike Keilty (Endress+Hauser AG) thanked Chair Glass and the TG for their
22 work and requested that Block 1, LPG-15.1, N.3. and Block 1 MFM-15.1, N.3 be removed from Block 1 items and to
23 allow those items to move forward separate from the other Block 1 Items. Mr. Keilty stated that similar language was
24 added to the Hydrogen code and that the proposed language in LPG-15.1 N.3. and MFM-15.1, N.3 will allow for the
25 recognition of master meters as field standards. Mr. Henry Oppermann (WM-Consulting), stated that data is needed
26 to ensure that master meters can be used over a range of conditions. Mr. Bob Murnane (Seraphin) stated that
27 jurisdictions have the ability to use meters and that Block 1 LPG-15.1, N.3 and Block 1 MM-15.1, N.3 should remain
28 in Block 1 until data is available to support the use of master meters as a standard. Mr. Keilty mentioned that there
29 has been useful dialog regarding master meters in the TG, but that he is concerned that the TG is not close to deciding
30 and he expressed concerns with the TG’s focus on the NIST Master Meter Project. Ms. Tina Butcher (NIST OWM)
31 provided an update on the NIST Master Meter Project and noted that States have the regulatory powers to accept or
32 reject a standard. She also mentioned that NIST is working with States to collect data needed to assess master meters
33 and preliminary testing was conducted and data was collected on CNG at Tulsa Gas Technology’s facility in fall 2019.
34 Ms. Diane Lee (NIST OWM) noted that NIST OWM feels that it is premature to add more language to the NIST
35 Handbook 44 on master meters without data to support its use.

36 During the Committee’s work session, the Committee agreed to keeps all items in Block 1 and that this item should
37 remain with an Assigned status.

38 NCWM 2021 Annual Meeting: Mr. Glass reported that he would be stepping down as the Field Standard TG Chair.
39 The Committee heard updates from members of the Task Group during open hearings. Mr. Mike Keilty
40 (Endress+Hauser AG) noted that two of the items had been on the agenda since 2015 and requested that they be
41 removed from the block and recommended recognizing the use of master meters. Other comments were to keep the
42 items together until data is analyzed from the NIST Field Reference Standard Work Group to support the use of master
43 meters but that if some items were removed from the block, all items should be removed from the block. Based on
44 comments heard during the 2021 Annual Meeting, the S&T Committee recommended that all items that were included
45 in Block 1 “Terminology For Testing Standards” that originally appeared as a separate item or a separate block of
46 items on the S&T agenda in and prior to 2019, be removed from Block 1 “Terminology For Testing Standards” and
47 appear as originally presented.

1 During the 2021 Committee work session the Committee recognized that the Task Group has accomplished all it is
2 able to at this point and is recommending the Task Group be disbanded and will make said recommendation to the
3 NCWM Chairman. The Committee agreed to break all items in Block 1 into individual items and designate them all
4 as Developing. The Committee thanks the Task Group and its members for their work.

5 NCWM 2022 Interim Meeting:

6 Item under consideration presented to 2022 NCWM Interim meeting as:

7 **N.3. Test Drafts.**

8 **N.3.1 Minimum Test** - Test drafts should be equal to at least the amount delivered by the device in 1 minute
9 at its normal discharge rate.

10 (Amended 1982)

11 **N.3.2. Field Reference Standard Meter Test. – The minimum quantity for any test draft shall be equal**
12 **to or greater than the amount delivered in one minute at the flow rate being tested.**
13 **(Added 20XX)**

14 Mr. Keilty shared a presentation on field standard meters during open hearings relevant to both LPG 15.1 and MFM
15 15.1. The intent of the presentation was to describe initial and ongoing calibration traceability, compare OIML
16 tolerances vs NIST Handbook 44, describe the benefits and show example. An abbreviated copy of the presentation
17 is available on the NCWM website in the interim meeting documents archive. Mr. Keilty commented that he believes
18 LPG 15.1 and MFM 15.1 are fully developed and should receive voting status for the annual meeting. He has updated
19 the proposal to exclude the term “reference” from “field reference standard meter test”, as shown above. He requests
20 that the committee provide specific guidance if a developing status is assigned. A comment from industry (Bob
21 Murnane – Seraphin) stated that N.3.2 in the proposal conflicts with the current code which states normal test drafts
22 must be at least one minute at the maximum discharge flow rate of installation conditions. The current wording allows
23 for a test to be conducted at any flow rate for one minute. There was concern from a regulator (Charles Stutesman,
24 Kansas) echoing these concerns. Diane Lee (NIST) requested that more data be made available so that NIST is able
25 to compare worldwide data against test data compiled within the US by NIST. Mahesh Albuquerque (Colorado)
26 expressed support for this item to receive voting status. Marc Butler (Emerson Micro Motion) expressed confusion at
27 the two notes, thinking that perhaps they conflicted with each other; are they both needed or are they independent?
28 Tina Butcher (NIST) expressed that she recognizes the use and importance of master meters, but is concerned with
29 the purpose of this item. Tina suggests that the statement for use be reworked as test draft criteria is so critical. Tina
30 recommended and offered NIST OWM assistance on this item.

31 During the S&T Committee work session, the committee recognized the submitters desire that a voting status be
32 recommended but determined that there were too many concerns and confusion expressed. The committee
33 recommends that the submitter develop the item further by aligning language to existing language in Handbook 44,
34 clarifying the purpose to help avoid confusion of the new code on new equipment, and reaching out to NIST OWM
35 or other industry or regulatory officials for feedback.

36 2022 NCWM Annual Meeting: The committee heard from Tina Butcher NIST, the submitter of the item. She stated
37 that they had addressed items heard at the fall regional meeting and the 2022 interim NCWM meeting. She stated they
38 felt the item as is ready to move forward in tandem with Block 7. The intent is to clarify that it isn’t necessary to
39 identify what type of standard is to be used, i.e.: provers aren’t referenced in section 3.30. OWM also provided written
40 comments on this item.

41 **Regional Associations’ Comments:**

42 WWMA 2021 Annual Meeting: Michael Keilty (Endress + Hauser) : in 2014 - he submitted a form 15 to edit content
43 and add N.3.2. It was set to developing. Several W/M officials have supported this. Asks that this be a voting item in
44 2022. Bob Murnane (Seraphin) : this is to allow a field reference standard meter, this definition does not currently
45 exist. Recommends that this be withdrawn so that the definitions can be worked out. Diane Lee (NIST OWM) : this
46 item was put forth in 2015 - purpose was: to accept a specific master meter in the field. It's not necessary to ref. field
47 ref. standards in specific code. NIST and states are working to collect data to see if master meters can be used. States

1 are to determine which standards are to be used in the states. N.3.2 was an issue. there was no information as to justify
 2 a different test draft size than was specified in N.3 or if it is necessary to use a field reference meter. Bruce Swiecicki
 3 (National Propane Gas Association): he lent support to this discussion (master meters). It would be nice to have
 4 something in HB44 to assist in uniformity. Michael Keilty (Endress + Hauser) : to address Diane Lee: he agrees and
 5 disagrees. Agree: it was stated that jurisdictions are responsible for their own equipment, however, he was told by
 6 states that they need something in HB44 to tell them what should be used. Again - wants voting on this item in 2022.

7 The WWMA S&T Committee recommends the status remain developmental. The Committee recommends that
 8 consideration be made that this item be included in Block 5, as they refer to the same terminology in HB:44. A letter
 9 was submitted to the Committee by Michael Keilty (Endress + Hauser) and will be posted to the NCWM website.
 10 NIST OWM also submitted analysis on this item which can be found at the following link on the NCWM website :
 11 <https://www.ncwm.com/annual-archive>

12 SWMA 2021 Annual Meeting: Mr. Oppermann, Seraphin, supports the Withdrawal of this item because it is
 13 unnecessary, as master meters can already be recognized as field standards. Mr. Keilty, Endress+Hauser, the submitter
 14 of this item, supports striking “Reference” and “Meter” from this proposal, and moving it forward as a Voting Item.
 15 This committee feels that the item is fully developed and is looking forward to seeing more data on the performance
 16 accuracy of master meters by the states that are currently using these devices.

17 This committee recommends this item move forward as a Voting item with the editorial changes requested by Mr.
 18 Keilty.

19 CWMA 2022 Annual Meeting: Micheal Keilty – Endress+Hauser – Mr. Keilty presented calibration data at the 2022
 20 NCWM Interim meeting. No recommendations from NCWM have been released. Recommended a minor change that
 21 re-includes the word “meters” because it was confusing how to apply testing requirements. Both items explain the
 22 amount of test drafts that differ from other volume standards. Field standard meter provides flexibility for use across
 23 many different products and densities. Field Standards are tested against OIML and API standards using gravimetric
 24 methods that are NIST traceable. Accuracy and repeatability are long term, it is a maintenance free system with no
 25 moving parts. These systems save time and space, contain embedded diagnostics, are easy to use, and easy to maintain.
 26 It is easy to train the operator of these systems. NMI has issued a test report on this system. Various setups can be
 27 mounted to a rack and easily transported. SWMA and CWMA recommended this item move forward as voting item
 28 in the 2021 Interim meeting. Recommending placing as voting today and move forward for a vote this week.

29
 30 Jan Konijnenburg – NIST OWM - State and industry have a need to use various types of field test standards to evaluate
 31 commercial devices installed in the marketplace. NIST OWM recognizes the need to use various standards to test
 32 commercial devices and support the use of these standards when test data supports its use.

33 The NIST OWM is also supporting the use of various types of field test standards through the purchase of several
 34 meters and the collection of data throughout the U.S.

35 The purpose statement for Items LPG-15.1 (LPG & Anhydrous Ammonia Liquid-Measuring Devices Code) indicates
 36 the goal of this items is:

37 “to amend Handbook 44 to allow field reference standard meters to be used to test and place into service dispensers
 38 and delivery system flow meters.”

39 The proposed changes in Items LPG-15.1 suggest changes to the test draft criteria for devices covered under this code,
 40 which is not necessary to allow field reference standard meters to be used to test and place into service dispensers and
 41 delivery system flow meters.

42 Amongst the concerns raised to the S&T Committee over the proposed changes for LPG-15.1 is that it conflicts with
 43 existing test draft criteria and confusion over the application of the proposed requirement.

- 1 As such, given the long debate over multiple iterations of the proposals, OWM proposes that since the purpose of the
2 proposal is to allow field reference standard meters to be used to test and place into service dispensers and delivery
3 system, and the responsibility for allowance of these field test standards are already addressed in the NIST Handbook
4 44 Fundamental Considerations and Item Block 8 clarifies these responsibilities, that Consideration be given to the
5 proposal in Item Block 8 which clearly states the responsibility for allowance of field standards along with a new
6 proposal to add a general code requirement. (See Item Block 8 of the NIST OWM Analysis for the S&T Annual
7 Meeting)
8
- 9 OWM Recommendation OWM recommends that this item be withdrawn and that consideration be given to Item Block
10 8.
11 Mike Johnson – NE – Supports this item and agrees with Mr. Keilty. Nebraska has had great success over the last 18
12 years using this method. Nebraska has over 300 mass flow meters and gravimetric testing isn't practical.
13
- 14 Bob Murnane – Seraphin –
15 The stated purpose on these proposals to amend Handbook 44 and to allow field standards meters to be used to test
16 and place into service dispensers and delivery system flow meters. The current language adding N.3.2., has nothing
17 to do with the purpose statement nor does have any effect at all on whether meters can be accepted or used as field
18 standards.
- 19 Handbook 44 under fundamental considerations already allows for the use of field standards and /or equipment, as
20 approved by the Director. There are already numerous meters in the field being used as standards that have been
21 approved by State Directors under these fundamental considerations.
- 22 Note: Seraphin has a proposal, item OTH-22-1 that supports the Directors authority.
- 23 What is the reason and justification for N.3.2 when we already have a test draft size in N.3.1?
- 24 What data and analysis has been provided regarding the uncertainties associated with the field standard meters and
25 the sizes of the drafts proposed in N.3.2.?
- 26 The proposal MFM-15.1., N.3.2 would impose constraints on the capability of the W&M officials to test mass flow
27 meters.
- 28 Under the current paragraph N.3., W&M officials can conduct tests at any flow rate for any quantity that is equal to
29 or greater than minimum measured quantity (MMQ) specified by the manufacture of the meter.
- 30 Under the proposed N.3.2., the minimum size of the test drafts must be greater than or equal to the quantity delivered
31 in one minute at the flow rate at which the test is being conducted. Depending upon the measurement application and
32 the test equipment available, this could substantially increase the size of the required test drafts for almost all flow
33 rates for mass flow meters.
- 34 Example: Recently there was CNG testing performed in Colorado. The test drafts were for 1/3 of the capacity of the
35 test cylinder (as specified in the EPO) and it took less than one minute to complete. In this case the proposed change
36 to the size of the test draft on MFM15.1. would have prevented Weights & Measures officials from conducting the
37 tests.
- 38 Weights and Measures officials should be able to test mass flow meters using any test draft size, equal to or greater
39 than the MMQ over the range of flow rates. I did not do an extensive review but I did find six NTEP Certificates of
40 Conformance that would not be able to be tested using the proposed MFM-15.1., N.3.2. What happens to them?
41 If the proposal were adopted with its current purpose statement it could be interrupted that every meter is acceptable
42 for use as a field standard. How do you know which meters are acceptable for use as a field standard and which ones
43 are not? For example, if a meter is brought into the United States from another country, can it be used as a field
44 standard. This proposal will cause confusion for both Weights and Measure officials and testing companies.
- 45 Additional Notes:

1 NIST and Seraphin requested Mike Keilty's participation in a meeting on these items and he declined.
2 There has been a total of six changes to the wording on these items since they were introduced.
3 Again, I would like to remind the committee that states are already using meters as field standards and this is permitted
4 by the existing fundamental considerations. There is no need for these proposals. Seraphin Test Measures opposes
5 items LPG-15.1. and MFM-15.1 and ask the committee to withdraw this item from consideration.
6 Comment: Years on an agenda are not part of criteria for deciding if an item should be made a voting item.

7
8 Charlie Stutesman – KS - Regarding Fundamental Considerations: states already have the ability to decide what's
9 allowed. It already falls within The Director's authority, but we have other existing codes in HB44 which reference
10 transfer standards and specifically allowing their use for testing particular devices. The NIST EPOs are still in draft
11 status and are a resource tool only. Flow rate will be more important going forward as gravimetric testing becomes
12 more prevalent. Recommends sending to voting status. Does this only apply to mass flow meters as the standard?
13 NIST stated they are using Coriolis meters. But the decision to use non-mass flow meters as the field standard rests
14 with The Director. This will apply to any meter technology, not just mass flow meters.

15
16 Michael Keilty – Endress+Hauser - Other codes in HB44 contain advice on specific test drafts when using transfer
17 standards. These proposals give test draft advice to handle slow flow devices. The EPO for CNG testing uses small
18 containers but the EPO can be changed.

19
20 Ivan Hankins – IA – Mr. Hankins has witnessed these tests using these transfer standards at multiple flow rates and
21 drafts. It took much less time. This technology will allow jurisdictions to test at a quicker pace, using less staff.
22 Supports this proposal.

23
24 Bob Murnane – Seraphin – Mr. Murnane questioned if the draft size is merely a suggestion.

25
26 The CWMA S&T Committee recommends this moves forward as a voting item

27 NEWMA 2022 Annual Meeting: Mr. Bob Murnane (Seraphin) commented that he does not believe this item is fully
28 developed and recommended that the committee consider withdrawing the item. Mr. Murnane read from submitted
29 comments. Of note, MR. Murnane indicated that under the Fundamental Considerations in HB44, the State Director
30 has the authority to evaluate standards for use in certifying meters and the fear is that if this proposal goes through,
31 the handbook would have to be changed for each new technology. Mr. Murnane explained that several states have
32 already evaluated meters to use as standards and determined them to be accurate to use. If this proposal is adopted,
33 Mr. Murnane believes that it would take powers away from State Directors to evaluate and use these standards. Ms.
34 Tina Butcher (NIST OWM) commented that the concept of master and reference meter is to use the meter as a standard
35 in place of provers. The authority to use them rests with the State Director, however, there needs to be a method to
36 ensure accuracy. Ms. Butcher mentioned several alternatives as outlined in the submitted NIST analysis.

37
38 During open hearings, comments were heard from the floor regarding this item and MFM-15.1 at the same time.

39
40 After hearing comments from the floor, the committee does not believe the item is fully developed, even though the
41 item has been on the agenda for several years. The committee recommended that the item be withdrawn.

42 Additional letters, presentation and data may have been submitted for consideration with this item. Please refer to
43 www.ncwm.com/publication-15 to review these documents.

LPG-15.1

Regional recommendation to NCWM on item status:

- Recommend as a Voting Item on the NCWM agenda
- Recommend as an Information Item on the NCWM agenda
- Recommend as an Assigned Item on the NCWM agenda
(To be developed by an NCWM Task Group or Subcommittee)
- Recommend as a Developing Item on the NCWM agenda
(To be developed by source of the proposal)
- Recommend Withdrawal of the Item from the NCWM agenda
(In the case of new proposals, do not forward this item to NCWM)
- No recommendation from the region to NCWM
(If this is a new proposal, it will not be forwarded to the national committee by this region)

Comments and justification for the regional recommendation to NCWM: *(This will appear in NCWM reports)*

The following comments were received during the 2022 SWMA Annual Meeting:

Mr. Keilty of Endress+Hauser, the submitter of this item, recommends it move forward as a voting item with the new language.

The SWMA S&T Committee recommends this item move forward as a Voting Item.

1

2 **MLK – MILK METERS**

3 **MLK-23.2 Table T.1. Tolerances for Milk Meters**

4 **Source:**

5 Milk Meter Tolerances Task Group

6 **Purpose:**

7 Eliminate the current tolerance structure of a decreasing permissible tolerance allowance as the size of the test draft
8 increases.

9 **Item Under Consideration:**

10 Amend Handbook 44, Milk Meters Code, as follows:

11 **T.2. Tolerance Values.** – Tolerances shall be as shown in Table 1. Tolerances for Milk Meters.

12 (Amended 1989, **20XX**)

Table 1. Tolerances for Milk Meters		
Indication (gallons)	Maintenance Tolerance (gallons)	Acceptance Tolerance (gallons)
100	0.5	0.3
200	0.7	0.4
300	0.9	0.5
400	1.1	0.6
500	1.3	0.7
Over 500	Add 0.002 gallon per indicated gallon over 500	Add 0.001 gallon per indicated gallon over 500

1 (Added 1989)

2

Table 1. Tolerances for Milk Meters		
	<u>Acceptance Tolerance</u>	<u>Maintenance Tolerance</u>
<u>Complete Measuring System</u>	<u>0.5%</u>	<u>0.5%</u>
<u>Meter Only</u>	<u>0.3%</u>	<u>0.3%</u>

3 **(Amended 20XX)**

4 **Previous Action:**
5 2023: New Item

6 **Original Justification:**
7 This is a companion item to VTM-20.2 [Vehicle Mounted Milk Meters] currently being considered. It would be logical
8 to block these two items as the data and discussion for changes to both Handbook 44 sections will be identical. This
9 proposal is being made to eliminate the current tolerance structure of a decreasing permissible tolerance allowance as
10 the size of the test draft increases. The proposed changes are identical to the current tolerance structure in the
11 international community that follow OIML R-117. Without the changes to the tolerances, it would be possible for a
12 device to be within tolerance at small test drafts and be out of tolerance for larger test drafts that are more representative
13 of a typical delivery.
14

15 If OIML tolerances are adopted, the tolerances that are currently in place may increase at larger test drafts.

16 **Requested Status by Submitter:** Voting Item

17 **Comments in Favor:**

18 **Regulatory:**

- 19 •

20 **Industry:**

- 21 •

22 **Advisory:**

- 23 •

1 **Comments Against:**

2 **Regulatory:**

- 3 •

4 **Industry:**

- 5 •

6 **Advisory:**

- 7 •

8 **Neutral Comments:**

9 **Regulatory:**

- 10 •

11 **Industry:**

- 12 •

13 **Advisory:**

- 14 •

15 **Item Development:**

16 **New**

17 Additional letters, presentation and data may have been submitted for consideration with this item. Please refer to
18 www.ncwm.com/publication-15 to review these documents.

MLK-23.2	
Regional recommendation to NCWM on item status:	
<input type="checkbox"/>	Recommend as a Voting Item on the NCWM agenda
<input type="checkbox"/>	Recommend as an Information Item on the NCWM agenda
<input checked="" type="checkbox"/>	Recommend as an Assigned Item on the NCWM agenda <i>(To be developed by an NCWM Task Group or Subcommittee)</i>
<input type="checkbox"/>	Recommend as a Developing Item on the NCWM agenda <i>(To be developed by source of the proposal)</i>
<input type="checkbox"/>	Recommend Withdrawal of the Item from the NCWM agenda <i>(In the case of new proposals, do not forward this item to NCWM)</i>
<input type="checkbox"/>	No recommendation from the region to NCWM <i>(If this is a new proposal, it will not be forwarded to the national committee by this region)</i>
Comments and justification for the regional recommendation to NCWM: <i>(This will appear in NCWM reports)</i>	
The following comments were received during the 2022 SWMA Annual Meeting:	
Dr. Curran, State of Florida, stated that he opposed raising the tolerances to accommodate this new device.	
No comments were received from the Milk Meter Tolerance Task Group.	
The SWMA S&T Committee recommends this item be Assigned to the Milk Meter Tolerance Task Group.	

19

1 **MFM – MASS FLOW METERS**

2 **MFM-15.1 D N.3. Test Drafts.**

3 **Previously MFM-2**

4 *Note: In 2019 this item was combined with Block 1 “Terminology For Testing Standards” and other items that*
 5 *addressed terminology for standards and the use of “master meters.” Based on comments heard during the 2021*
 6 *Annual Meeting, the S&T Committee recommended that all items that were combined with Block 1 “Terminology For*
 7 *Testing Standards” that originally appeared as a separate item or a separate block of items on the S&T agenda prior*
 8 *to 2019, be removed from Block 1 “Terminology For Testing Standards” and appear as originally presented.*
 9 *Item MFM-15.1 was removed from Block 1 “Terminology For Testing Standards” and now appears as a separate*
 10 *item on the 2022 Interim Meeting agenda.*

11 **Source:**

12 Endress + Hauser Flowtec AG USA

13 **Item Under Consideration:**

14 Amend Handbook 44, Mass Flow Meters Code as follows:

15 **N.3. Test Drafts.**

16 **N.3.1 Minimum Test** - The minimum test shall be one test draft at the maximum flow rate of the installation
 17 and one test draft at the minimum flow rate. More tests may be performed at these or other flow rates. (See
 18 T.3. Repeatability.)
 19 (Amended 1982 **and 20XX**)

20 **N.3.2. Field Reference Standard Meter Test. – The minimum quantity for any test draft shall be equal**
 21 **to or greater than the amount delivered in one minute at the flow rate being tested.**
 22 **(Added 20XX)**

23 **Background/Discussion:**

24 This item has been assigned to the submitter for further development. For more information or to provide comment,
 25 please contact:

26 Mr. Michael Keilty
 27 Endress + Hauser Flowtec AG USA
 28 970-586-2122, michael.keilty@us.endress.com

29 The use of transfer standards is recognized in Code sections 3.34 Cryogenic Liquid-Measuring Devices Code and 3.38
 30 Carbon Dioxide Liquid-Measuring Devices Code and 3.39 Hydrogen Gas-Measuring Devices – Tentative Code.
 31 Transfer standard is only defined for testing cryogenic liquid measuring devices. It has been pointed out that the term
 32 transfer standard is not correct and that field reference standard meters may be more appropriate. See new the item
 33 under consideration, updated on September 8, 2017.

34 Field evaluation of LPG meters and CNG dispensers and LNG dispensers is very difficult using volumetric and
 35 gravimetric field standards and methods. The tolerances for these applications are such that using field reference
 36 standard meters are more efficient and safer. With CNG and LNG and LPG applications, the field reference standard
 37 meters are placed in-line with the delivery system as it is used to fill tanks and vehicles. The use of field reference
 38 standard meters eliminates return to storage issues. The use of field reference standard meters is easier and faster
 39 compared to the use of traditional field standards. The cost of using field reference standard meters and transporting
 40 them is much less than the cost of traditional field provers and standards.

41 Recognition in Handbook 44 will enable States to allow field reference standard meters to place systems into service
 42 and for field enforcement.

1 Volumetric field provers and gravimetric field proving are susceptible to environmental influences. The State of
2 Colorado uses a field reference standard meter to test propane delivery truck meters. The State of Nebraska has used
3 a field reference standard meter to test agricultural chemical meters. Other States have asked that there be recognition
4 in HB44 in order for their State to allow the use of field reference standard meters.

5 In some applications, field reference standard meters are not more accurate than the meters used in the application.
6 For that reason, longer test drafts and possibly more tests may need to be run.

7 The State of California is purported to have conducted a short study of field reference standard meters in the past. The
8 conclusion did not lead to wide adoption of the practice.

9 Section 3.37 Mass Flow Meters user requirement U.R.3.8. Return of Product to Storage, Retail Compressed Natural
10 Gas Dispensers requires that the natural gas which is delivered into the test container must be returned to storage. This
11 is difficult and most often not complied with when the test vessel contents are released to atmosphere. States often
12 have difficulties in remote locations finding suitable field reference equipment.

13 In the fall of 2016, Mr. Keilty provided an update to the Item under Consideration. That update appears in the agenda.
14 The previous proposed Item under Consideration was as follows:

15 **N.3. Test Drafts. –**
16

17 **N.3.1 Minimum Test** - Test drafts should be equal to at least the amount delivered by the device in one
18 minute at its normal discharge rate.
19 (Amended 1982)
20

21 **N.3.2. Transfer Standard Test. – When comparing a meter with a calibrated transfer standard, the**
22 **test draft shall be equal to at least the amount delivered by the device in 2 minutes at its maximum**
23 **discharge rate.**

24 The submitter recommends that NIST update EPO 28 for CNG dispensers and EPO 26 for LPG Liquid Measuring
25 Systems to include transfer standard meter tests. NIST Publication R 105-4 should also be revised to specifically
26 address the transfer standard meter and the requirements for use.

27 The S&T Committee might also consider amending Sections 3.30 Liquid-Measuring Devices Code and 3.31 Vehicle-
28 Tank Meters Code to allow transfer standard meters.

29 The Committee received written comments on all items in Block 4 and Block 5, as well as LPG-4 and MFM-2
30 emphasizing the need for there to be more study and discussion of the issues to assess the ramifications of all the
31 proposed changes. The Committee also received written comments from the SMA that it looks forward to further
32 information on these items and stating that it is important to be consistent in our use of terms across multiple sections
33 of Handbook 44. The Committee agreed to carryover this group of items on its 2019 agenda to allow for further
34 discussion and development of these proposals.

35 **NCWM 2019 Interim Meeting:** The S&T Committee decided to combine the items on the agenda dealing with the
36 issue of transfer standard (including items already combined into blocks) into one block. Block 1 (New) of the Interim
37 Meeting report now includes GEN-3, Block 1 (original items from the 2019 interim agenda that appeared under Block
38 1), Block 2, LPG-3, and MFM-5, which were all separate items and blocks of items on the S&T Committee's 2019
39 Interim Meeting agenda (NCWM Publication 15). Agenda items GEN-3, Block 1, Block 2, LPG-3, and MFM-5 are
40 listed separately on the Interim agenda with a note added beneath each individual item referring the reader to the New
41 B1 items. All items under this New B1 have retained the same numbering system for ease in referring to the appendix
42 for discussion on each item.

43 **NCWM 2019 Annual Meeting:** Mr. Brett Gurney (NCWM Chairman) commented regarding the formation of a Task
44 Group assigned to further develop this block proposal. The TG is charged with providing definitions for various types
45 of standards (transfer, field, reference, etc.) as well as the criteria to be met by these types of standards. The completion

1 date given to the TG is July 2021. The Committee agreed to the Assigned status for this block of items and looks
2 forward to hearing updates from the TG. The Chair of the task group was:

3 Mr. Jason Glass
4 Kentucky Department of Agriculture
5 502-573-0282, jason.glass@ky.gov

6 NCWM 2020 Interim Meeting: Field Standard TG Chair, Jason Glass reported that the Task Group met prior to the
7 Interim meeting and has begun discussion of the items under Block 1. Mr. Glass stated that bi-weekly teleconference
8 meetings were scheduled and that the group was optimistic but had significant work to accomplish.

9 Mr. Russ Vires (SMA) supports the Scale item, SCL 18.1; in this block, Mr. Dimitri Karimov (Meter Manufacturers
10 Association) supports the Task Group activities, Ms. Tina Butcher was encouraged with the progress on terminology
11 and provided an update on the Mass Flow Meter testing reporting that field testing was conducted October 28 to
12 November 1, 2019 and that State and Industry participation included Colorado, Florida, Oregon, Emerson, and Tulsa
13 Gas Technology.

14 Mr. Kurt Floren (Los Angeles Co., CA) raised concerns with GEN-19.1. regarding the definition of “Standard, Field”
15 and its reference to “stable” standards and how long a standard is expected to be stable, which is typically 1-year, for
16 which he believes should be longer. Mr. Floren also questioned the statement in the definition “tested over a range of
17 environmental and operational conditions that the measuring devices is used...” Mr. Floren noted that he was unsure
18 if all laboratories will have the capabilities to test over this wide range of conditions. Mr. Floren also expressed
19 concerns with the definition “Standard, Transfer” citing that this standard may not meet the fundamental
20 considerations requirement for standards over a long period of time or wide range of environmental conditions.

21 Mr. Steve Harrington (OR) echoed Mr. Floren’s comments. Field Standard TG Chair Glass responded that these are
22 concerns of the TG and these issues will be discussed and considered as the TG develops these items.

23 During the Committee’s work session, the Committee agreed that this item should remain an Assigned item.

24 NCWM 2021 Interim Meeting: NCWM Field Standard TG Chair, Mr. Jason Glass (KY) provided an update on the
25 Task Group activities. Mr. Glass reported that the field standard Task Group is following the activities of the NIST
26 Master Meter Project and that the Task Group reviewed API specifications for use of master meters as a standard and
27 a test protocol that will be used to ensure uniformity in collecting data on master meters used as field standards. Mr.
28 Glass also reported that the TG does not have a recommendation for this item. Mr. Glass also reported that he would
29 be stepping down as the TG Chair. Mr. Mike Keilty (Endress+Hauser AG) thanked Chair Glass and the TG for their
30 work and requested that Block 1, LPG-15.1, N.3. and Block 1 MFM-15.1, N.3 be removed from Block 1 items and to
31 allow those items to move forward separate from the other Block 1 Items. Mr. Keilty stated that similar language was
32 added to the Hydrogen code and that the proposed language in LPG-15.1 N.3. and MFM-15.1, N.3 will allow for the
33 recognition of master meters as field standards. Mr. Henry Oppermann (W&M Consulting), stated that data is needed
34 to ensure that master meters can be used over a range of conditions. Mr. Bob Murnane (Seraphin) stated that
35 jurisdictions have the ability to use meters and that Block 1 LPG-15.1, N.3 and Block 1 MM-15.1, N.3 should remain
36 in Block 1 until data is available to support the use of master meters as a standard. Mr. Keilty mentioned that there
37 has been useful dialog regarding master meters in the TG, but that he is concerned that the TG is not close to deciding
38 and he expressed concerns with the TG’s focus on the NIST Master Meter Project. Ms. Tina Butcher (NIST OWM)
39 provided an update on the NIST Master Meter Project and noted that States have the regulatory powers to accept or
40 reject a standard. She also mentioned that NIST is working with States to collect data needed to assess master meters
41 and preliminary testing was conducted and data was collected on CNG at Tulsa Gas Technology’s facility in fall 2019.
42 Ms. Diane Lee (NIST OWM) noted that NIST OWM feels that it is premature to add more language to the NIST
43 Handbook 44 on master meters without data to support its use.

44 During the Committee’s work session, the Committee agreed to keeps all items in Block 1 and that this item should
45 remain with an Assigned status.

1 NCWM 2021 Annual Meeting: Mr. Glass reported that he would be stepping down as the Field Standard TG Chair.
2 The Committee heard updates from members of the Task Group during open hearings. Mr. Michael Keilty noted that
3 two of the items had been on the agenda since 2015 and requested that they be removed from the block and
4 recommended recognizing the use of master meters. Other comments were to keep the items together until data is
5 analyzed from the NIST Field Reference Standard Work Group to support the use of master meters but that if some
6 items were removed from the block, all items should be removed from the block. Based on comments heard during
7 the 2021 Annual Meeting, the S&T Committee recommended that all items that were included in Block 1
8 “Terminology For Testing Standards” that originally appeared as a separate item or a separate block of items on the
9 S&T agenda in and prior to 2019, be removed from Block 1 “Terminology For Testing Standards” and appear as
10 originally presented.

11 During the 2021 Committee work session the Committee recognized that the Task Group has accomplished all it is
12 able to at this point and is recommending the Task Group be disbanded and will make said recommendation to the
13 NCWM Chairman. The Committee agreed to break all items in Block 1 into individual items and designate them all
14 as Developing. The Committee thanks the Task Group and its members for their work.

15 NCWM 2022 Interim Meeting:

16 Item under consideration presented to 2022 NCWM Interim meeting as:

17 **N.3. Test Drafts.**

18 **N.3.1 Minimum Test** - The minimum test shall be one test draft at the maximum flow rate of the installation and
19 one test draft at the minimum flow rate. More tests may be performed at these or other flow rates. (See T.3.
20 Repeatability.)
21 (Amended 1982 **and 20XX**)

22 **N.3.2. Field Reference Standard Meter Test. – The minimum quantity for any test draft shall be equal to**
23 **or greater than the amount delivered in one minute at the flow rate being tested.**
24 **(Added 20XX)**

25 Mr. Keilty shared a presentation on field standard meters during open hearings relevant to both MFM 15.1 and LPG
26 15.1. The intent of the presentation was to describe initial and ongoing calibration traceability, compare OIML
27 tolerances vs NIST Handbook 44, describe the benefits and show example. An abbreviated copy of the presentation
28 is available on the NCWM website in the interim meeting documents archive. Mr. Keilty commented that he believes
29 MFM 15.1 and LPG 15.1 are fully developed and should receive voting status for the annual meeting. He has updated
30 the proposal to exclude the term “reference” from “field reference standard meter test”, as shown above. He requests
31 that the committee provide specific guidance if a developing status is assigned. A comment from industry (Bob
32 Murnane – Seraphin) stated that N.3.2 in the proposal conflicts with the current code which states normal test drafts
33 must be at least one minute at the maximum discharge flow rate of installation conditions. The current wording allows
34 for a test to be conducted at any flow rate for one minute. There was concern from a regulator (Charles Stutesman,
35 Kansas) echoing these concerns. Diane Lee (NIST) requested that more data be made available so that NIST is able
36 to compare worldwide data against test data compiled within the US by NIST. Mahesh Albuquerque (Colorado)
37 expressed support for this item to receive voting status. Marc Butler (Emerson Micro Motion) expressed confusion at
38 the two notes, thinking that perhaps they conflicted with each other; are they both needed or are they independent?
39 Tina Butcher (NIST) expressed that she recognizes the use and importance of master meters, but is concerned with
40 the purpose of this item. Tina suggests that the statement for use be reworked as test draft criteria is so critical. Tina
41 recommended and offered NIST OWM assistance on this item.

42 During the S&T Committee work session, the committee recognized the submitters desire that a voting status be
43 recommended but determined that there were too many concerns and confusion expressed. The committee
44 recommends that the submitter develop the item further by aligning language to existing language in Handbook 44,
45 clarifying the purpose to help avoid confusion of the new code on new equipment, and reaching out to NIST OWM
46 or other industry or regulatory officials for feedback.

1 2022 NCWM Annual Meeting: The committee heard comments from, Michael Keilty with Endress+Hauser Flow
 2 USA, the submitter of the item. The submitter voiced frustration that this item was developing because two regions
 3 (SWMA and CWMA) recommended it as voting and the WWMA recommended withdrawal without a reason. The
 4 submitter testified that at one regional meeting a jurisdiction gave a presentation on how easy the technology was to
 5 use. He fails to understand some groups show opposition to this item. He ask that the item be moved to voting at the
 6 next meeting and urged states to support it. The submitter also provided written comments to the committee.

7 **Regional Associations' Comments:**

8 WWMA 2021 Annual Meeting: Michael Keilty (Endress + Hauser): companion item to LPG-15.1. this is enabling
 9 language. Wants this to be a voting item in 2022. Bob Murnane (Seraphin): does not recognize the verbiage, needs a
 10 definition - see previous comments (referencing LPG-15.1, field reference standard meter). Diane Lee (NIST OWM):
 11 agree with Michael about companion item. Clarification to both items: MFM-15.1 - in HB the purpose statement is
 12 not there. In Amendment A there is already criteria there. Needed justification for language in N.3.2 - standard meter
 13 test - the min. quant. for any test draft shall be equal to or greater than am. delivered in 1 min. of the amount being
 14 tested. in CNG there is a 1/3 test being conducted. it wouldn't even take a minute to deliver. the question was: how
 15 do you come up with 1 min. and this would not be appropriate for all master meters. Michael Keilty (Endress +
 16 Hauser): addressing Diane: in 2016 there was supposed to be a vote. NIST tech. adviser brought this up. There was a
 17 revision to the time to be extended. CNG is completely separate, EPO does say 1/3 but that was when CNG tanks
 18 were small (delivered at lower flow rate and shorter time). Mr. Wagner can verify. he made it 1 min. because N.3.1
 19 says one test draft at the max. flow rate and one at the min. flow rate of installation. The WWMA S&T Committee
 20 recommends the status remain developmental.

21 The Committee recommends that consideration be made that this item be included in Block 5, as they refer to the
 22 same terminology in HB:44. A letter was submitted to the Committee by Michael Keilty (Endress + Hauser) and will
 23 be posted to the NCWM website. NIST OWM also submitted analysis on this item which can be found at the following
 24 link on the NCWM website: <https://www.ncwm.com/annual-archive>

25 SWMA 2021 Annual Meeting: Mr. Oppermann, Seraphin, stated that this creates a conflict with the Mass Flow Meter
 26 code regarding the minimum test. He also stated that he believes this item is unnecessary, because Field Standard
 27 Tests are already specified. Mr. Keilty, Endress+Hauser, the submitter, suggested an editorial revision to some terms.
 28 He stated that he simply wants the use of master meters recognized as Field Standards and recommends tis item be
 29 oved forward as Voting with the revisions made.

30 This committee feels this item is fully developed and recommends it be moved forward as a Voting item.

31 CWMA 2022 Annual Meeting: Michael Keilty-Endress+Hauser Flow asked that the item be moved to voting and if
 32 not, asks for suggestions from Michael Keilty – Endress+Hauser – Mr. Keilty presented calibration data at the 2022
 33 NCWM Interim meeting. No recommendations from NCWM have been released. Recommended a minor change that
 34 re-includes the word “meters” because it was confusing how to apply testing requirements. Both items explain the
 35 amount of test drafts that differ from other volume standards. Field standard meter provides flexibility for use across
 36 many different products and densities. Field Standards are tested against OIML and API standards using gravimetric
 37 methods that are NIST traceable. Accuracy and repeatability are long term, it is a maintenance free system with no
 38 moving parts. These systems save time and space, contain embedded diagnostics, are easy to use, and easy to maintain.
 39 It is easy to train the operator of these systems. NMI has issued a test report on this system. Various setups can be
 40 mounted to a rack and easily transported. SWMA and CWMA recommended this item move forward as voting item
 41 in the 2021 Interim meeting. Recommending placing as voting today and move forward for a vote this week.

42
 43 Jan Konijnenburg – NIST OWM - State and industry have a need to use various types of field test standards to evaluate
 44 commercial devices installed in the marketplace. NIST OWM recognizes the need to use various standards to test
 45 commercial devices and support the use of these standards when test data supports its use.

46 The NIST OWM is also supporting the use of field test standards through the purchase of several meters and the
 47 collection of data throughout the U.S.

48 The purpose statement for Item MFM-15.1 (Mass Flow Meters Code) indicates the goal of this item is:

1 “to amend Handbook 44 to allow field reference standard meters to be used to test and place into service dispensers
2 and delivery system flow meters.”
3 The proposed changes in Items MFM-15.1 suggest changes to the test draft criteria for devices covered under this
4 code, which is not necessary to allow field reference standard meters to be used to test and place into service dispensers
5 and delivery system flow meters.
6 Amongst the concerns raised to the S&T Committee over the proposed changes for MFM-15.1, is the inability for an
7 inspector or service company to test devices under their conditions of use and as required elsewhere in the MFM code.
8 As such, given the long debate over multiple iterations of the proposals, OWM proposes that since the purpose of the
9 proposal is to allow field reference standard meters to be used to test and place into service dispensers and delivery
10 system, and the responsibility for allowance of these field test standards are already addressed in the NIST Handbook
11 44 Fundamental Considerations and Item Block 8 clarifies these responsibilities, that Consideration be given to the
12 proposal in Item Block 8 which clearly states the responsibility for allowance of field standards along with a new
13 proposal to add a general code requirement. (See Item Block 8 of the NIST OWM Analysis for the S&T Annual
14 Meeting)
15
16 OWM Recommendation OWM recommends that this item be withdrawn and that consideration be given to Item Block
17 8.
18
19 Mike Johnson – NE – Supports this item and agrees with Mr. Keilty. Nebraska has had great success over the last 18
20 years using this method. Nebraska has over 300 mass flow meters and gravimetric testing isn’t practical.
21
22 Bob Murnane – Seraphin –
23 The stated purpose on these proposals to amend Handbook 44 and to allow field standards meters to be used to test
24 and place into service dispensers and delivery system flow meters. The current language adding N.3.2., has nothing
25 to do with the purpose statement nor does have any effect at all on whether meters can be accepted or used as field
26 standards.
27 Handbook 44 under fundamental considerations already allows for the use of field standards and /or equipment, as
28 approved by the Director. There are already numerous meters in the field being used as standards that have been
29 approved by State Directors under these fundamental considerations.
30 Note: Seraphin has a proposal, item OTH-22-1 that supports the Directors authority.
31 What is the reason and justification for N.3.2 when we already have a test draft size in N.3.1?
32 What data and analysis has been provided regarding the uncertainties associated with the field standard meters and
33 the sizes of the drafts proposed in N.3.2.?
34 The proposal MFM-15.1., N.3.2 would impose constraints on the capability of the W&M officials to test mass flow
35 meters.
36 Under the current paragraph N.3., W&M officials can conduct tests at any flow rate for any quantity that is equal to
37 or greater than minimum measured quantity (MMQ) specified by the manufacture of the meter.
38 Under the proposed N.3.2., the minimum size of the test drafts must be greater than or equal to the quantity delivered
39 in one minute at the flow rate at which the test is being conducted. Depending upon the measurement application and
40 the test equipment available, this could substantially increase the size of the required test drafts for almost all flow
41 rates for mass flow meters.
42 Example: Recently there was CNG testing performed in Colorado. The test drafts were for 1/3 of the capacity of the
43 test cylinder (as specified in the EPO) and it took less than one minute to complete. In this case the proposed change
44 to the size of the test draft on MFM15.1. would have prevented Weights & Measures officials from conducting the
45 tests.

1 Weights and Measures officials should be able to test mass flow meters using any test draft size, equal to or greater
 2 than the MMQ over the range of flow rates. I did not do an extensive review but I did find six NTEP Certificates of
 3 Conformance that would not be able to be tested using the proposed MFM-15.1., N.3.2. What happens to them?

4 If the proposal were adopted with its current purpose statement it could be interrupted that every meter is acceptable
 5 for use as a field standard. How do you know which meters are acceptable for use as a field standard and which ones
 6 are not? For example, if a meter is brought into the United States from another country, can it be used as a field
 7 standard. This proposal will cause confusion for both Weights and Measure officials and testing companies.

8 Additional Notes:

9 NIST and Seraphin requested Mike Keilty’s participation in a meeting on these items and he declined.

10 There has been a total of six changes to the wording on these items since they were introduced.

11 Again, I would like to remind the committee that states are already using meters as field standards and this is permitted
 12 by the existing fundamental considerations. There is no need for these proposals. Seraphin Test Measures opposes
 13 items LPG-15.1. and MFM-15.1 and ask the committee to withdraw this item from consideration.

14 Comment: Years on an agenda are not part of criteria for deciding if an item should be made a voting item.

15
 16 Charlie Stutesman – KS - Regarding Fundamental Considerations: states already have the ability to decide what’s
 17 allowed. It already falls within The Director’s authority, but we have other existing codes in HB44 which reference
 18 transfer standards and specifically allowing their use for testing particular devices. The NIST EPOs are still in draft
 19 status and are a resource tool only. Flow rate will be more important going forward as gravimetric testing becomes
 20 more prevalent. Recommends sending to voting status. Does this only apply to mass flow meters as the standard?
 21 NIST stated they are using Coriolis meters. But the decision to use non-mass flow meters as the field standard rests
 22 with The Director. This will apply to any meter technology, not just mass flow meters.

23
 24 Michael Keilty – Endress+Hauser - Other codes in HB44 contain advice on specific test drafts when using transfer
 25 standards. These proposals give test draft advice to handle slow flow devices. The EPO for CNG testing uses small
 26 containers but the EPO can be changed.

27 Ivan Hankins – IA – Mr. Hankins has witnessed these tests using these transfer standards at multiple flow rates and
 28 drafts. It took much less time. This technology will allow jurisdictions to test at a quicker pace, using less staff.
 29 Supports this proposal.

30
 31 Bob Murnane – Seraphin – Mr. Murnane questioned if the draft size is merely a suggestion.

32
 33 The CWMA S&T Committee recommends this moves forward as a voting item.

34 NEWMA 2022 Annual Meeting: Mr. Bob Murnane (Seraphin) commented that he does not believe this item is fully
 35 developed and recommended that the committee consider withdrawing the item. Mr. Murnane read from submitted
 36 comments. Of note, MR. Murnane indicated that under the Fundamental Considerations in HB44, the State Director
 37 has the authority to evaluate standards for use in certifying meters and the fear is that if this proposal goes through,
 38 the handbook would have to be changed for each new technology. Mr. Murnane explained that several states have
 39 already evaluated meters to use as standards and determined them to be accurate to use. If this proposal is adopted,
 40 Mr. Murnane believes that it would take powers away from State Directors to evaluate and use these standards. Ms.
 41 Tina Butcher (NIST OWM) commented that the concept of master and reference meter is to use the meter as a standard
 42 in place of provers. The authority to use them rests with the State Director, however, there needs to be a method to
 43 ensure accuracy. Ms. Butcher mentioned several alternatives as outlined in the submitted NIST analysis.

44
 45 During open hearings, comments were heard from the floor regarding this item and LPG-15.1 at the same time.

46

- 1 After hearing comments from the floor, the committee does not believe the item is fully developed, even though the
2 item has been on the agenda for several years. The committee recommended that the item be withdrawn.
- 3 Additional letters, presentation and data may have been submitted for consideration with this item. Please refer to
4 www.ncwm.com/publication-15 to review these documents.

MFM-15.1	
Regional recommendation to NCWM on item status:	
<input checked="" type="checkbox"/> Recommend as a Voting Item on the NCWM agenda <input type="checkbox"/> Recommend as an Information Item on the NCWM agenda <input type="checkbox"/> Recommend as an Assigned Item on the NCWM agenda <i>(To be developed by an NCWM Task Group or Subcommittee)</i> <input type="checkbox"/> Recommend as a Developing Item on the NCWM agenda <i>(To be developed by source of the proposal)</i> <input type="checkbox"/> Recommend Withdrawal of the Item from the NCWM agenda <i>(In the case of new proposals, do not forward this item to NCWM)</i> <input type="checkbox"/> No recommendation from the region to NCWM <i>(If this is a new proposal, it will not be forwarded to the national committee by this region)</i>	
Comments and justification for the regional recommendation to NCWM: <i>(This will appear in NCWM reports)</i>	
The following comments were received during the 2022 SWMA Annual Meeting: Mr. Keilty, Endress+Hauser, stated that the purpose statement was left out of the proposal when it moved from Block 8. It has now been added. He also submitted new language for N.3.2. <u>N.3.2. Field Standard Meter Test.-The minimum quantity for any test draft shall be equal to or greater than the amount delivered in one minute at the flow rate being tested except for tests of the minimum measured quantity specified for the meter.</u> The SWMA S&T Committee recommends this item move forward as a Voting Item with the language above included.	

5

6 HGM – HYDROGEN GAS-MEASURING DEVICES

7 HGM-23.1 UR.3.8. Safety Requirement

8 **Source:**

9 Quong and Associates, Inc.

10 **Purpose:**

11 Add safety requirement for hydrogen gas measuring devices.

12 **Item under Consideration:**

13 Amend Handbook 44 Hydrogen Gas-Metering Devices Code as follows:

14 **UR 3.8 Safety Requirement –All hydrogen gas-measuring devices subject to this code shall maintain**
15 **verification of testingdemonstrating conformance with the latest version of SAE J2601 Fuel Protocols for Light**
16 **Duty Gaseous Hydrogen SurfaceVehicles, as determined by the latest version of ANSI/CSA HGV 4.3 “Test**
17 **Methods for Hydrogen Fueling Parameter Evaluation.**
18 **(Nonretroactive as of January 1, 10XX)**

1 Previous Action:

2 New item in 2023.

3 Original Justification:

4 The proper fueling of hydrogen vehicles is critical to ensure that the vehicle and high pressure tank is not damaged.
5 Unlike other gases, such as compressed natural gas, hydrogen heats as a vehicle is fueled due to the reverse Joule-
6 Thompson effect. This means that the fueling rate and temperature of the hydrogen must be carefully controlled, or
7 damage can occur to the vehicle hydrogen tanks. The hydrogen industry has done considerable work in developing
8 standard fueling protocols in SAE

9 J2601 (https://www.sae.org/standards/content/j2601_202005/) and validation methods in ANSI/CSA HGV
10 4.3 (<https://www.csagroup.org/store/product/CSA%25100ANSI%20HGV%204.3%3A22/>) to ensure that the
11 vehicles are fueled correctly and safely.

12
13 The validation of SAE J2601 using ANSI/CSA HGV 4.3 has been performed on the 50+ hydrogen stations
14 in California by the Air Resources Board (ARB) ([https://ww2.arb.ca.gov/resources/documents/annual-
15 hydrogen-evaluation](https://ww2.arb.ca.gov/resources/documents/annual-hydrogen-evaluation)). The proposed requirement provides assurances that dispensers have been verified to
16 the proper fueling protocol which will protect the dispenser, vehicle, and consumer.

17
18 While the California Department of Food and Agriculture is discussing submitting the same language for the
19 California Code of Regulations, adding the same language of Handbook 44 would allow other states to understand
20 and adopt the key hydrogen fueling protocol standards, thereby expanding the use of hydrogen throughout the United
21 States.

22 The submitter acknowledged that some may argue that the equipment to validate stations is not available except in
23 California.

24
25 The submitter's response would be that, first, there are other private companies who have the equipment to test
26 dispensers outside of California, including stations in the northeast US. Second, HGV 4.3 allows for factory
27 acceptance testing of dispensers prior to installation and an abbreviated Site Acceptance Test. This approach
28 shortens the time and equipment necessary to verify a station meets SAE J2601. Third, the design and software of
29 the Hydrogen Station Equipment Performance (HyStEP) Device device used by ARB is publicly available.
30 (<https://h2tools.org/hystep-hydrogen-station-equipment-performance-device>).

31 The submitter provided the following links:

32 SAE J2601: https://www.sae.org/standards/content/j2601_202005/ (copyrighted)

33 ANSI/CSA HGV 4.3 (<https://www.csagroup.org/store/product/CSA%25100ANSI%20HGV%204.3%3A22/>)
34 (copyrighted)

35 California Air Resources Board: Annual Evaluation of Fuel Cell Electric Vehicle Deployment & Hydrogen
36 Fuel Station Network Development

37 <https://ww2.arb.ca.gov/resources/documents/annual-hydrogen-evaluation> (many reports available, latest is too
38 large to attach)

39 EVSE Pre_Rule Wkshop Shared Deck.pdf

40 The submitter requested that this be a Voting item in 2023.

1 **Comments in Favor:**

2 **Regulatory:**

- 3 •

4 **Industry:**

- 5 •

6 **Advisory:**

- 7 •

8 **Comments Against:**

9 **Regulatory:**

- 10 •

11 **Industry:**

- 12 •

13 **Advisory:**

- 14 •

15 **Neutral Comments:**

16 **Regulatory:**

- 17 •

18 **Industry:**

- 19 •

20 **Advisory:**

- 21 •

22 **Item Development:**

23 New

24 Additional letters, presentation and data may have been submitted for consideration with this item. Please refer to
25 www.ncwm.com/publication-15 to review these documents.

HGM-23.1	
Regional recommendation to NCWM on item status:	
<input type="checkbox"/> Recommend as a Voting Item on the NCWM agenda <input type="checkbox"/> Recommend as an Information Item on the NCWM agenda <input type="checkbox"/> Recommend as an Assigned Item on the NCWM agenda <i>(To be developed by an NCWM Task Group or Subcommittee)</i> <input checked="" type="checkbox"/> Recommend as a Developing Item on the NCWM agenda <i>(To be developed by source of the proposal)</i> <input type="checkbox"/> Recommend Withdrawal of the Item from the NCWM agenda <i>(In the case of new proposals, do not forward this item to NCWM)</i> <input type="checkbox"/> No recommendation from the region to NCWM <i>(If this is a new proposal, it will not be forwarded to the national committee by this region)</i>	
Comments and justification for the regional recommendation to NCWM: (This will appear in NCWM reports)	
The following comments were received during the 2022 SWMA Annual Meeting:	
Dr. Curran, State of Florida, questioned whether this was the proper venue for this item.	
Mr. Floyd, State of Louisiana, also commented that this was not the proper venue for this item.	
This committee would like the NCWM S&T Committee to consider whether or not this type of item is within the scope of weights and measures.	
The SWMA S&T Committee recommends this item move forward as a Developing Item.	

1

2 **EVF – ELECTRIC VEHICLE FUELING SYSTEMS**

3 **EVF-21.1 D A.1. General**

4 **Source:**

5 ABB, BTCPower, Electrify America, Edison Electric Institute, EVConnect, EVgo, Greenlots, Rivian, Siemens, Tesla,
 6 Tritium

7 **Purpose:**

8 To provide clarity on how Handbook 44, Sec. 3.4 tentative code will apply to existing EVSE that are in the ground
 9 before it becomes effective by identifying which elements are non-retroactive.

10 **Item Under Consideration:**

11 Amend Handbook 44, Electric Vehicle Fueling Systems as follows:

12 **A.1. General** – This code applies to devices, accessories, and systems used for the measurement of electricity
 13 dispensed in vehicle fuel applications wherein a quantity determination or statement of measure is used wholly
 14 or partially as a basis for sale or upon which a charge for service is based.

15 **A.1.1 Effective Dates for DC EVSE – All DC EVSE used for commercial purposes and put into**
 16 **service on or before January 1, 2023 are exempt from this standard for a period of 10 years from the**
 17 **date put into service. comply**
 18

1 **A 1.2 Effective Dates for AC EVSE – All AC EVSE used for commercial purposes and put into service**
2 **on or before January 1, 2022 are exempt from this standard for a period of 10 years from the date put**
3 **into service.**

4 **Previous Action:**

- 5 • 2021: Developing
- 6 • 2022: Developing

7 **Original Justification:**

8 While it is important to ensure that consumers are receiving accurate and transparent information regarding the
9 accuracy of EV charging stations, the cost to retrofit existing stations that often do not include an integrated meter,
10 especially DCFC where commercial DC metering technology is not readily available today, will be cost prohibitive.
11 In CA Initial Statement of Reasons (ISOR) for adopting specifications and tolerances requirement for commercial
12 EVSE, CA estimated that it costs approximately \$4,500 to upgrade existing Level 2 stations and \$20,000 to upgrade
13 existing DCFC. To put this into context, CA DMS utilized 2015 DOE data stating that the average commercial Level
14 2 EVSE costs between \$3,000-\$6,000 and the average DCFC up to \$40,000 or more. The retrofit costs would represent
15 a significant investment amount that does not seem warranted. The ISOR is available here:
16 https://www.cdfa.ca.gov/dms/pdfs/regulations/EVSE_ISOR.pdf. According to DOE AFDC station locator there are
17 23,000 level 2 station with 66,000 connectors in the U.S. and 3,700 DCFC stations with 14,000 connectors. Being
18 conservative and utilizing just the number of stations, it would cost \$92M to upgrade the existing Level 2 station in
19 the U.S. today and \$74M to upgrade the existing DCFC stations, a number that is expected to grow as more stations
20 are deployed. Placing this excessive upgrade burden on manufacturers and network operators is not feasible and an
21 alternative pathway needs to be explored to ensure consumer transparency and EVSE accuracy for existing stations
22 without requiring extensive retrofits. This number also does not include the amount of public funding across various
23 states that has been invested in these EVSE that would prematurely potentially be ripped out and replaced. It could
24 also have the unintended consequence that the EV industry stops charging for charging services at existing sites or
25 shut them down if the investment in retrofits is greater than the benefit of continuing to operate. Stranded assets across
26 the country are a valid concern and should not be taken lightly. It is important to not prematurely replace EVSE in
27 the field until the useful life of the system has been obtained. Spending a significant amount of capital to upgrade
28 existing stations rather than investing in new infrastructure does not appear aligned with EV deployment goals.
29 Therefore, it is recommended that there is consideration for making sure requirements are non-retroactive and there
30 is a phase in timeline for existing stations. The language utilized above is similar to what CA DMS implemented,
31 which was the first state to adopt a version of Handbook 44 Sec 3.4 for EVSE. The date for DC EVSE is set at January
32 1, 2023 to match California’s timeline but also because this is when DC metering technology is expected to be
33 commercially available in the market and integrated into DC EVSE by most EVSE manufacturers that are either
34 working on their own product or with third party meter manufacturers.

35 In general, it appears that there is some openness to considering how legacy EVSE that are in the ground today should
36 be treated when considering that DC metering technology integrated into the EVSE was not commercially available
37 when many of these stations were developed. The main concern that has been raised is regarding whether there should
38 be an overall exemption for existing EVSE to the measurement provisions in HB 44 Sec 3.4 or whether existing EVSE
39 should be exempt from certain requirements in the subsections of Sec 3.4 that are not feasible to attain. In reviewing
40 the subsections of Sec 3.4, the proposal submitters determined that it would not be feasible to meet most subsections
41 of Sec 3.4 with equipment that is in the ground with the exception of S.5 Marking (except S.5.2) and S.6 printing
42 requirements. To ensure there is not confusion between which stations were in the ground prior to dates referenced
43 above, EVSE owners and operators will need to work with local weights and measures officials on a self-reporting
44 mechanisms or some other mechanism for tracking station service dates. CA will be the first state that will need to
45 determine how this process will operate in the field given it has already adopted the exemption noted above and
46 compliance for new AC stations is effective January 1, 2021. On the consumer side, EVSE operators and owners
47 today can provide certain provisions to ensure the accuracy of the commercial transaction that can be facilitated outside
48 of having a meter integrated into the EVSE. For instance, some owners and operators may be able to utilize the
49 accuracy that is traceable via the measurement technology in the EV that accounts for any losses and ensure the
50 consumer is being accurately and fairly billed for what he or she is receiving.

51 The submitter requested voting status for this item in 2021.

1 **Comments in Favor:**2 **Regulatory:**

- 3 • 2021 Interim: Mr. Samuel Ferris (California) supported Developing status but noted that an exemption
- 4 from requirements in the handbook is not common and that the life span of the equipment may only be
- 5 seven to ten years.
- 6 • 2022 Interim: A regulator from Nevada supports developing status.
- 7 • 2022 Interim: A regulator from New York supports developing status and looks forward to reasonable
- 8 modifications of the proposal by the submitter. He does not favor a 10-year grace period and wishes
- 9 for a permanent code status.

10 **Industry:**

- 11 • 2021 Interim: Ms. Francesca Wahl (Tesla) and Mr. Keith Bradley (Electrify America) supported
- 12 Developing status.
- 13 • 2021 Interim: Ms. Francesca Wahl (Tesla) supported this item.
- 14 • 2021 Interim: Mr. Kevin Miller (Charge Point) expressed concerns with allowing an exemption for 10-
- 15 years and equipment should be able to meet the requirements and supports a Developing status for this
- 16 item.
- 17 • 2021 Annual: Ms. Francesca Wahl (Tesla) noted that she will be working to incorporate feedback and
- 18 will work with the EVF National Work group to develop an updated proposal. Ms. Wahl also provided
- 19 a letter to the S&T Committee concerning the Developing status for this item.
- 20 • 2022 Interim: A member of the submitting group recommends developing status and provided
- 21 background and stated they are working on revised draft for proposal. The submitters worked with NIST
- 22 OWM and EVFE Subgroup for feedback. The commentor stated a revised proposal will be developed
- 23 and noted there are significant modifications from the original proposal.
- 24 • 2022 Interim: A member of industry representing Electrify America, commented section 3.40 in
- 25 Handbook 44 was developed before the company was established. A revised proposal is expected to be
- 26 submitted. Recommends the item remain a developing item.
- 27 • 2022 Interim: A member of industry representing EVgo, a joint submitter recommends developing
- 28 status.
- 29

30 **Advisory:**

- 31 • 2022 Interim: No Comments
- 32

33 **Comments Against:**34 **Regulatory:**

- 35 • 2022 Interim: A regulator from California DMS recommends withdraw, however stated a developmental
- 36 status is acceptable.
- 37 • 2022 Interim: A regulator from New York would like to see a permanent code in the area EVFSs and
- 38 stated the 10-year exempt period is not acceptable. The commentor stated he is supportive of seeing
- 39 reasonable changes from the joint submitters.
- 40

41 **Industry:**

- 42 • 2022 Interim: A member of industry representing ChargePoint is not in support of this item and
- 43 recommends withdraw. He stated the proposal signals to the market things are in flux and supports
- 44 removal of the proposal and tentative code status. The industry member noted the recent passage of the
- 45 law providing \$7.8 billion in funding to invest in U.S. EV charging.
- 46

47 **Advisory:**

- 48 • 2021 Interim: Ms. Diane Lee (NIST OWM) noted that the proposal is not clear as written and expressed
- 49 concerns with an exemption for 10 years.
- 50 • 2021 Annual: Ms. Juana Williams (NIST OWM), stated that it was unclear as to the exact type of use
- 51 that entitles an EVSE to an exemption to NIST HB 44 requirements. Ms. Williams also pointed out that

1 the exemption would allow a generation of devices to operate for 10-years without have to comply with
2 the requirements and could be viewed as competitively unfair to traditional or other alternative vehicle
3 fueling applications.

- 4 • 2022 Interim: An advisory member representing NIST OWM stated the current proposal conflicts with
5 the general code for the term retroactive. The representative stated the submitters of the item discussed
6 an alternative proposal with NIST OWM and they are awaiting a final draft of this alternative proposal.

7
8 **Neutral Comments:**

9 **Regulatory:**

- 10 • 2022 Interim: No Comments

11
12 **Industry:**

- 13 • 2022 Interim: No Comments

14
15 **Advisory:** 2022 Interim: No Comments

16 **Item Development:**

17 NCWM 2021 Interim Meeting: The committee assigned Developing status for this item. For more information or to
18 provide comment, please contact:

19 Ms. Francesca Wahl
20 Tesla
21 650-435-0422, fwahl@tesla.com

22 The Committee suggests that the submitters of this item consider the responses to the proposal from the regional
23 meetings, NIST, OWM and EVFS work group and update the item under consideration to address the comments and
24 as necessary prepare a revised proposal for the EVFS work group to address the concerns with this item.

25 NCWM 2022 Interim Meeting: The Committee maintained developing status for this item. The Committee suggests
26 the submitters take into consideration the comments provided during open hearings and prepare a revised draft
27 proposal to NIST OWM, the EVFE Subgroup, etc. to provide a comprehensive proposal to membership.

28 NCWM 2022 Annual Meeting: The Committee heard an update from Ms. Francesca Wahl (Tesla) on behalf of the
29 joint submitters where she provided a combined update to items EVF 21.1 and EVF 21.5. The workgroup has met on
30 multiple occasions since the NCWM 2022 Interim meeting in efforts develop these two items for vote. Ms. Wahl
31 commented there are specifics in both items that need further discussion and development. Examples include, but are
32 not limited to, timelines and effective dates, along with addressing tolerance values as they relate to existing
33 equipment. Ms. Wahl stated efforts are being made to develop the items for vote in the next cycle.

34 **Regional Associations' Comments:**

35 WWMA 2021 Annual Meeting: Justin Wilson (ChargePoint): in the notes for 2021(Interim) there is an error: the
36 notations are incorrect. They recommend withdraw of this proposal. They think the flexibility should be provided to
37 state officials. Kevin Schnepf (California - DMS): extended exemptions are not appropriate - this is still tentative.
38 This should be withdrawn.

39 The WWMA S&T Committee recommends this item be Withdrawn. The Committee makes this recommendation
40 based on testimony heard during the open hearings and previous reports including recommendations from other
41 Regions.

42 SWMA 2021 Annual Meeting: The committee received no comments on this item. This committee recommends this
43 item be Withdrawn due to the item allowing a 10-year exemption.

1 CWMA 2022 Annual Meeting: Francesca Wahl – Tesla - Working with NIST EVFE Subgroup to revamp proposal
 2 and focusing on DC. Wants to remain development status. Supports current HB44 3.40 tentative code acceptance in
 3 the very near future.

4
 5 The CWMA S&T Committee recommends this item remain as a developing item per the request of the submitter.

6
 7 NEWMA 2022 Annual Meeting: Ms. Tina Butcher (NIST OWM) commented that this item was originally submitted
 8 by a group of manufacturers. The item went to EV-USNWG, received feedback and the submitters have been working
 9 to address comments from national and regional levels. Mr. Alex Beaton (EVGo) commented as one of the submitters.
 10 He indicated that the submitters heard feedback from regulators regarding the originally proposed 10-year exemption
 11 for EV meters and has modified the proposal. For DC meters, the submitters are looking to propose that all meters
 12 manufactured prior to 2024 will be subject to 5% accuracy tolerance and those manufactured after 2024 will be subject
 13 to a 1% accuracy tolerance. Both percentages for accuracy have been supported by data. For AC meters, Mr. Beaton
 14 indicated that prior changes to the proposal have been removed as the submitters believe with calibration, all meters
 15 can meet current code. Mr. Beaton believes the updated proposal will be available prior to the 2022 Annual Meeting.

16
 17 After hearing comments from the floor, the committee recognized the need to further develop this item and
 18 recommended the item retain developing status. The committee suggested that the submitters to continue to work
 19 with regulatory stakeholders and share data in order to further the development of the item, and urges the timely
 20 submission of proposals for committee to review prior to annual and interim meetings.

21 Additional letters, presentation and data may have been submitted for consideration with this item. Please refer to
 22 www.ncwm.com/publication-15 to review these documents.

EVF-21.1
<p>Regional recommendation to NCWM on item status:</p> <ul style="list-style-type: none"> <input type="checkbox"/> Recommend as a Voting Item on the NCWM agenda <input type="checkbox"/> Recommend as an Information Item on the NCWM agenda <input type="checkbox"/> Recommend as an Assigned Item on the NCWM agenda <i>(To be developed by an NCWM Task Group or Subcommittee)</i> <input type="checkbox"/> Recommend as a Developing Item on the NCWM agenda <i>(To be developed by source of the proposal)</i> <input checked="" type="checkbox"/> Recommend Withdrawal of the Item from the NCWM agenda <i>(In the case of new proposals, do not forward this item to NCWM)</i> <input type="checkbox"/> No recommendation from the region to NCWM <i>(If this is a new proposal, it will not be forwarded to the national committee by this region)</i>
<p>Comments and justification for the regional recommendation to NCWM: <i>(This will appear in NCWM reports)</i></p> <p>The following comments were received during the 2022 SWMA Annual Meeting:</p> <p>Scheleese Goudy of Electrify America, the submitter of this item, requested that it be withdrawn.</p> <p>The SWMA S&T Committee recommends this item be Withdrawn.</p>

23

24 **EVF-21.5 D T.2. Load Test Tolerances.**

25 **Source:**
 26 ABB, BTPower, Electrify America, Edison Electric Institute, EVConnect, EVgo, Greenlots, Rivian, Siemens, Tesla,
 27 Tritium

28 **Purpose:**

1 To create separate metering requirements for DC EVSE due to significant technology differences and challenges
2 between AC and DC systems.

3 **Item Under Consideration:**

4 Amend Handbook 44, Electric Vehicle Fueling Systems as follows:

5 **T.2. Load Test Tolerances.**

6 **T.2.1. AC EVSE Load Test Tolerances.** – The tolerances for AC EVSE load tests are:

7 (a) Acceptance Tolerance: 1.0 %; and

8 (b) Maintenance Tolerance: 2.0 %.

9 **T.2.2. DC EVSE Load Test Tolerances.** – **The tolerances for DC EVSE load tests:**

10 (a) **Devices installed prior to January 1, 2033**

11 i. **Acceptance Tolerance: 2.5 %; and**

12 ii. **Maintenance Tolerance: 5.0 %**

13 (b) **Devices installed January 1, 2033 or later**

14 i. **Acceptance Tolerance: 1.0 %; and**

15 ii. **Maintenance Tolerance: 2.0 %**

16 **Previous Action:**

- 17 • 2021: Developing
- 18 • 2022: Developing

19 **Original Justification:**

20 Proposed changes to the text to differentiate alternating current (AC) EVSE from direct current (DC) EVSE. Metering
21 for DC architected systems is considerably more complicated and in ways that the original drafting of this provision
22 never contemplated. For example, the tentative code when initially written never contemplated 350kW EVSE or liquid
23 cooled cabling from the charging post to the connector. As such, it is necessary to separate the implementation dates
24 of some of the specifications, tolerances, and other technical requirements. DC metering solutions are still being
25 researched and developed and are not yet commercially available to be integrated into DC chargers at scale and at
26 reasonable cost. While the supply chain for the physical meters themselves is slowly catching up, the metering system
27 in a DC EVSE, particularly high-power DC EVSE that utilize liquid-cooled cables, goes beyond the physical meter
28 itself which is incorporated in the main housing of the EVSE. For example, measurements may also need to be taken
29 at the connector end of the dispenser and software and algorithms must be developed, validated, and integrated into
30 the EVSE system to allow for accurate metering of kWh delivered to the vehicle. Implementing more complex
31 metering systems needed for DCFC requires significant design and manufacturing changes to DC EVSE.

32 The proposed tolerances account for the fact that these systems are still in development and are untested. The proposed
33 timeline provides the industry with enough time to develop, test, validate, and deploy reliable DC metering system
34 technology. This timeline is also consistent with the timeline approved by the State of California which accounts for
35 the vast majority of the EVSE market. EVSE manufacturers are working diligently to meet the California timeline and
36 are confident that it can be met.

37 While it is important to ensure that consumers are receiving accurate and transparent information regarding the
38 accuracy of EV charging stations, it is also important that the technology to deliver high accuracy is available and
39 reliable.

1 There is concern about both the proposed timeline and the accuracy requirement. Some are concerned that the accuracy
 2 specification of 2.5% acceptance and 5% maintenance is too high and does not provide sufficient consumer confidence
 3 that all charge sessions are equal regardless of provider and station. The proposers would note that this is a new and
 4 evolving technology where charging providers place a premium on customer experience as they compete for this
 5 growing market. Thus far, customers have not registered complaints about lack of transparency. Some are concerned
 6 that the timeline for instituting a metering regime is too far into the future. The proposers acknowledge the few years
 7 it will take to have reliable DC metering systems commercially available at scale but are working as quickly as possible
 8 to develop and integrate these systems into their chargers. Some are also concerned that the metering requirements
 9 have been in a place for several years already and therefore the EVSE community should not need more years to
 10 develop solutions. The proposers note that current DC EVSE technology was never contemplated by the existing
 11 metering regime and DC technology, particularly high-power DC EVSE, were not in existence at the time the original
 12 specifications were set. For example, the first 350kWh EVSE with liquid cooled cables weren't deployed in the US
 13 until 2018.

14 The submitter requested voting status for this item in 2021.

15 **Comments in Favor:**

16 **Regulatory:**

- 17 • 2021 Interim: Recommended Developing status.
- 18 • 2022 Interim: A regulator from Nevada supports developing status.

19 **Industry:**

- 20 • 2021 Interim: Mr. Michael Krauthamer (AFTE) and Mr. Keith Bradley (Electrify America), supported
 21 the item and recommended Developing status.
- 22 • Annual 2021: The submitters requested to maintain Developing status.
- 23 • 2022 Interim: A member of the submitting group recommends the item remain developing. The
 24 commentator stated the group will be submitting a revised proposal addressing comments and feedback
 25 received.
 26

27 **Advisory:**

- 28 • 2022 Interim: No comments

29 **Comments Against:**

30 **Regulatory:**

- 31 • 2022 Interim: A regulator from California DMS recommends the item to be withdrawn.

32 **Industry:**

- 33 • Interim 2021: Mr. Samuel Ferris (CA) recommended a Developing status for this item. Mr. Kevin
 34 Miller (Charge Point) recommended that this item be withdrawn and noted that his devices meet the
 35 tolerance in NIST HB 44.
- 36 • 2022 Interim: A member of industry representing ChargePoint recommends withdraw of this item due
 37 to no details of the 2022 alternate proposals recently developed by the submitters.
 38

39 **Advisory:**

- 40 • 2022 Interim: An advisory member representing NIST OWM reiterated 2021 comments against
 41 blanket exemptions and dual tolerances yet awaits the rework of alternate proposals recently developed
 42 by the submitters that would be ready to be revisited in future EVFE Subgroup meetings. The member
 43 encourages the submitters to work with NIST OWM on the final draft of any proposed changes.
 44

45 **Neutral Comments:**

1 **Regulatory:**
2 • 2022 Interim: No comments

3
4 **Industry:**
5 • 2022 Interim: No comments

6 **Advisory:**
7 • 2022 Interim: No comments

8 **Item Development:**
9 2021 Interim Meeting: The Committee assigned Developing status for this item. For more information or to provide
10 comment, please contact:

11 Mr. Asaf Nagler
12 ABB
13 202-639-4075, asaf.nagler@us.abb.com

14 NCWM 2022 Interim Meeting: During the committee work session this item was assigned Developing status. The
15 Committee suggests the submitters take into consideration the comments provided during open hearings. The
16 Committee recommends the submitter work with NIST OWM on the final draft of their 2022 alternate proposal for
17 review and comments.

18 NCWM 2022 Annual Meeting: The Committee heard an update from Ms. Francesca Wahl (Tesla) on behalf of the
19 joint submitters where she provided a combined update to items EVF 21.1 and EVF 21.5. The workgroup has met on
20 multiple occasions since the NCWM 2022 Interim meeting in efforts develop these two items for vote. Ms. Wahl
21 commented there are specifics in both items that need further discussion and development. Examples include, but are
22 not limited to, timelines and effective dates, along with addressing tolerance values as they relate to existing
23 equipment. Ms. Wahl stated efforts are being made to develop the items for vote in the next cycle.

24 **Regional Associations' Comments:**

25 WWMA 2021 Annual Meeting: Kevin Schnepf (California - DMS): this was adopted in California Regulation. Just
26 this past week (September 23rd, 2021) a complete analysis was done and clearly identified that they can meet the 1%
27 tolerance. Recommends to be withdrawn. Justin Wilson (ChargePoint): Recommend to be withdrawn - equipment
28 can meet tolerance as is. Keith Bradley (Electrify America): there are two questions: 1 - can devices in near term meet
29 the tolerance? They are concerned with: when did this become possible? They are continuing to work on this. They
30 are not urging changes to this item - they are working on it. Wants to leave it in developing status - more work to be
31 done. Kurt Floren (LA County): when equipment is out there that is meeting the standards, this is not the time to roll
32 back.

33 The WWMA S&T Committee recommends this item be Withdrawn. The Committee makes this recommendation
34 based on testimony heard during the open hearings and previous reports including recommendations from other
35 Regions.

36 Note: In the voting session, Cadence Matijeich (NV) requested that the recommendation of withdrawal of this item
37 be changed to developing. The Committee reviewed item EVF 21.5 with consideration to the comment heard during
38 the voting session. It is the position of the Committee based on open hearings and regional input to recommend
39 withdraw of the item. The testimony provided during open hearings supported that devices can meet the current
40 tolerances.

41
42 The Committee's charge is to recommend a status to the National S&T Committee, this will not eliminate the item
43 from the agenda, it is our recommendation.

44 SWMA 2021 Annual Meeting: The committee received no comments on this item. This committee recommends this
45 item be Withdrawn because we believe that current tolerances are attainable.

1 CWMA 2022 Annual Meeting: Keith Bradley – Electrify America - Thanks to NIST for forming the work group.
 2 Industry has worked hard to determine compliance for existing devices. DC fast chargers already installed will have
 3 a larger retroactive tolerance. Recommended to remain as developing.
 4

5 Francesca Wahl – Tesla - Minor modifications outside of tolerances will still be needed in order for manufacturers to
 6 comply with changes to devices already in commercial use.
 7

8 Charlie Stutesman – KS – HB44 3.40 tentative code has been in place for 7 years. It needs to become active and
 9 enforceable.
 10

11 The CWMA S&T Committee recommends this item remain as a developing item per the request of the submitter.

12 NEWMA 2022 Annual Meeting: Ms. Tina Butcher (NIST OWM) commented that this item was originally submitted
 13 by a group of manufacturers. The item went to EV-USNWG, received feedback and the submitters have been working
 14 to address comments from national and regional levels. Mr. Alex Beaton (EVGo) commented as one of the submitters.
 15 He indicated that the submitters heard feedback from regulators regarding the originally proposed 10-year exemption
 16 for EV meters and has modified the proposal. For DC meters, the submitters are looking to propose that all meters
 17 manufactured prior to 2024 will be subject to 5% accuracy tolerance and those manufactured after 2024 will be subject
 18 to a 1% accuracy tolerance. Both percentages for accuracy have been supported by data. For AC meters, Mr. Beaton
 19 indicated that prior changes to the proposal have been removed as the submitters believe with calibration, all meters
 20 can meet current code. Mr. Beaton believes the updated proposal will be available prior to the 2022 Annual Meeting.
 21

22 After hearing comments from the floor, the committee recognized the need to further develop this item and
 23 recommended the item retain developing status. The committee suggested that the submitters to continue to work
 24 with regulatory stakeholders and share data in order to further the development of the item and urges the timely
 25 submission of proposals for committee to review prior to annual and interim meetings.

26 Additional letters, presentation and data may have been submitted for consideration with this item. Please refer to
 27 www.ncwm.com/publication-15 to review these documents.

EVF-21.5
<p>Regional recommendation to NCWM on item status:</p> <p> <input type="checkbox"/> Recommend as a Voting Item on the NCWM agenda <input type="checkbox"/> Recommend as an Information Item on the NCWM agenda <input type="checkbox"/> Recommend as an Assigned Item on the NCWM agenda <i>(To be developed by an NCWM Task Group or Subcommittee)</i> <input type="checkbox"/> Recommend as a Developing Item on the NCWM agenda <i>(To be developed by source of the proposal)</i> <input checked="" type="checkbox"/> Recommend Withdrawal of the Item from the NCWM agenda <i>(In the case of new proposals, do not forward this item to NCWM)</i> <input type="checkbox"/> No recommendation from the region to NCWM <i>(If this is a new proposal, it will not be forwarded to the national committee by this region)</i> </p>
<p>Comments and justification for the regional recommendation to NCWM: <i>(This will appear in NCWM reports)</i></p> <p>The following comments were received during the 2022 SWMA Annual Meeting:</p> <p>Ms. Goudy of Electrify America, the submitter of this item, requested that it be withdrawn.</p> <p>The SWMA S&T Committee recommends this item be Withdrawn.</p>

1 **EVF-23.1** **S.2.5.1., S.8., ~~S.5.3.(d), N.1., T.5., N.2., T.6., Appendix D—Definitions;~~**
2 **megajoule (MJ)**

3 **Source:**
4 NIST USNWG EVF&S-EVFE Subgroup

5 **Purpose:**
6 Further refine electrical vehicle fueling systems code requirements in NIST Handbook 44 *Specifications,*
7 *Tolerances, and Other Technical Requirements for Weighing and Measuring Devices* Section 3.40 Electric
8 Vehicle Fueling Systems Code to: (1) remove the “megajoule” unit of measurement definition and all references
9 to the term cited in the design specifications; (2) base the computation of the total sales price on a more appropriate
10 quantity interval that does not exceed 0.01 kWh rather than a 0.1 kWh; (3) decrease the permissible sizes of the
11 minimum measured quantity (MMQ) to those that are more appropriate quantities for AC and DC systems
12 deliveries and result in a shorter duration for the light load test procedure; and (4) no longer require an accuracy
13 test and the applicable test tolerances at no load and at starting load.

14 **Item under Consideration:**
15 Amend Handbook 44, Electric Vehicle Fueling Systems as follows:

16 **The EVFE Subgroup developed recommendations for modifying the code by removing the definition of**
17 **the unit of measurement for the “megajoule” from the handbook:**

18 ~~megajoule (MJ).—An SI unit of energy equal to 1 000 000 joules (J). [3.40]~~

19 The computed total price for the sale of electrical energy shall be based on an EVSE using a quantity interval that
20 does not exceed 0.01 kWh rather than 0.1 kWh or in units of the megajoule. The EVFE Subgroup also
21 recommends removing the megajoule unit of measurement from paragraph S.2.5.1. Money-Value Divisions
22 Digital as shown below:

23 *S.2.5.1. Money-Value Divisions Digital.* – An EVSE with digital indications shall comply with
24 the requirements of paragraph G-S.5.5. Money-Values, Mathematical Agreement, and the total price
25 computation shall be based on quantities not exceeding ~~0.5 MJ~~ or 0.01 kWh.

26 **(Amended 202X)**

27 **The EVFE Subgroup recommends modifying paragraph S.8. Minimum Measured Quantity (MMQ) to**
28 **recognize an MMQ of 0.1 kWh which is very common among EVSE that have already been type approved.**
29 **For ANSI C12 American National Standard for Electricity Meters—0.1, 0.2, and 0.5 Accuracy Classes**
30 **compliant meters meter constants of 0.001 kWh are common. In these meters the meter is expected to be**
31 **fully accurate at deliveries of only a single watthour (i.e., 0.001 kWh). Dispensing a larger amount of energy**
32 **to determine accuracy is not needed. Additionally, the EVFE Subgroup recommends paragraph S.8 specify**
33 **an MMQ not to exceed 1.0 kWh as a more appropriate quantity for DC systems and include a new note to**
34 **encourage a smaller MMQ for EVSEs which in the case of AC systems will result in a shorter time to**
35 **conduct a test by a factor of five.**

36 S.8. Minimum Measured Quantity (MMQ). – The minimum measured quantity shall satisfy the conditions of use
37 of the measuring system as follows:

38 (a) Measuring systems shall have a minimum measured quantity not exceeding ~~2.5 MJ~~ or:

39 **(1) 0.5 kWh for AC EVSE; and**

40 **(2) 1.0 kWh for DC EVSE.**

41 **Note: To minimize the duration of required testing, manufacturers may want to consider limiting the**
42 **declared MMQ to the level of 0.1 kWh for AC EVSE.**

1 **(Amended 202X)**

2 The EVFE Subgroup also recommends removing the term and abbreviation for the “joule” unit of measurement,
3 the No Load Test and Starting Load Test notes and their corresponding tolerances from the code requirements
4 because these conditions are never encountered by a customer. An EVSE never operates at no load for any
5 significant time. The Starting Load Test should not be required because the EVSE never operates at 0.5A.
6 Consequently, also modify the relevant handbook requirements as follows:

7 S.5.3. Abbreviations and Symbols.

8 (d) J=joule.

9 ~~N.1.No Load Test. A no load test may be conducted on an EVSE measuring system by applying rated~~
10 ~~voltage to the system under test and no load applied.~~

11 ~~T.5. No Load Test. An EVSE measuring system shall not register when no load is applied.~~

12 ~~N.2.Starting Load Test. A system starting load test may be conducted by applying rated voltage and~~
13 ~~0.5 ampere load.~~

14 ~~T.6.Starting Load. An EVSE measuring system shall register a starting load test at a 0.5 ampere (A) load.~~

15 **Renumber paragraph N.3. Minimum Test Draft (Size) through N.6. Repeatability Tests to become N.1.**
16 **through N.4., respectively**

17 **Previous Action:**

18 New item in 2023

19 **Original Justification:**

20 The EVFE Subgroup proposes deleting all references to the “megajoule” unit of measurement in the method of sale
21 regulation for retail sales of electrical energy as a vehicle fuel. This modification will align the unit of measurement
22 recognized for electrical energy vehicle fueling equipment (i.e., the kilowatt-hour) in corresponding legal metrology
23 requirements in NIST Handbook 44 Specifications, Tolerances, and Other Technical Requirements for Weighing and
24 Measuring Devices Section 3.40 Electric Vehicle Fueling Systems Code and corresponding international documentary
25 standards.

26 While objections to the proposed modifications may surface the group is not currently aware of any and these matters
27 would be brought to light during the August through October 2022 comment period. The EVFE Subgroup also notes
28 that the additional paragraphs it has recommended for modification are not recent developments but are the result of
29 information gathered through testing carried out over the past six years and input from OEMs on EVSEs and from
30 jurisdictions conducting tests and type evaluation of devices in field installations and laboratory environments;
31 therefore, this proposal is the result of advances in the operating capacity of EVSEs which indicate that modifications
32 to multiple paragraphs are warranted. Removing the “megajoule (MJ)” unit of measurement from the handbook does
33 not conform to the practice in place for applying the concept of primary use of SI (metric) measurements
34 recommended in the Omnibus Trade and Competitiveness Act of 1988. Although it appears that trade practice is
35 limited to use of the kilowatt-hour unit of measurement for electrical energy deliveries to an EV battery; if that practice
36 were to change the “joule” could be placed back into the handbook.

37 The submitter requested that this be a Voting item in 2023.

38 **Comments in Favor:**

39 **Regulatory:**

- 40 •

41 **Industry:**

- 42 •

1 **Advisory:**

- 2 •

3 **Comments Against:**

4 **Regulatory:**

- 5 •

6 **Industry:**

- 7 •

8 **Advisory:**

- 9 •

10 **Neutral Comments:**

11 **Regulatory:**

- 12 •

13 **Industry:**

- 14 •

15 **Advisory:**

- 16 •

17 **Item Development:**

18 New

19 Additional letters, presentation and data may have been submitted for consideration with this item. Please refer to
20 www.ncwm.com/publication-15 to review these documents.

EVF-23.1	
Regional recommendation to NCWM on item status:	
<input checked="" type="checkbox"/> Recommend as a Voting Item on the NCWM agenda <input type="checkbox"/> Recommend as an Information Item on the NCWM agenda <input type="checkbox"/> Recommend as an Assigned Item on the NCWM agenda <i>(To be developed by an NCWM Task Group or Subcommittee)</i> <input type="checkbox"/> Recommend as a Developing Item on the NCWM agenda <i>(To be developed by source of the proposal)</i> <input type="checkbox"/> Recommend Withdrawal of the Item from the NCWM agenda <i>(In the case of new proposals, do not forward this item to NCWM)</i> <input type="checkbox"/> No recommendation from the region to NCWM <i>(If this is a new proposal, it will not be forwarded to the national committee by this region)</i>	
Comments and justification for the regional recommendation to NCWM: (This will appear in NCWM reports)	
The following comments were received during the 2022 SWMA Annual Meeting:	
Ms. Goudy of Electrify America submitted the updated wording, which is newly adopted by the NIST workgroup as of October 2022. She recommends moving this item forward as a voting item with the following wording:	
S.2.5.1.	Money-Value Divisions Digital. – An EVSE with digital indications shall comply with the requirements of paragraph G-S.5.5. Money-Values, Mathematical Agreement, and the total price computation at the end of a transaction shall be based on quantities not exceeding 0.5 MJ or 0.01 kWh.
The SWMA S&T Committee recommends this item move forward as a Voting Item with the above wording.	

1

2 **EVF-23.2 S.2.7. Indication of Delivery**

3 **Source:**

4 Siemens Industry Inc., Smart Infrastructure eMobility

5 **Purpose:**

6 Provide consistent treatment of AC and DC chargers on the topic of Indication of Delivery.

7 **Item under Consideration:**

8 Amend Handbook 44, Electric Vehicle Fueling Systems as follows:

9 **S.2.7. Indication of Delivery.** – The EVSE shall automatically show on its face the initial zero condition and the
 10 quantity delivered (up to the capacity of the indicating elements). All **AC and** DC EVSE are exempt from this
 11 requirement until January 1, 2028

12 **Previous Action:**

13 New item in 2023

14 **Original Justification:**

15 At the 2022 NCWM, the conference recognized that for DC chargers, the vast majority of commercially deployed DC
 16 chargers do not have the Indication of Delivery specified in HB 44, and EV drivers are easily able to use them and
 17 pay for the charging by using a smart phone app. The same facts apply to AC chargers.

18

19 Most of the industry has not provided AC or DC chargers with an Indication of Delivery, because HB 44 was not
 20 adopted by any of the states until recently (FL in November 2021, with the advent of NTEP certification for AC
 21 chargers). The impact of additional states adopting NTEP certification without the proposed amendment would mean

1 that customers would be precluded from purchasing most brands of AC chargers. The effect would be to greatly reduce
2 both customer choice and competition, resulting in higher prices for AC chargers and slower deployment, which, in
3 turn, would slow EV adoption. Having fewer manufacturers competing in the market would also exacerbate AC
4 charger lack of availability due to supply chain issues. The NCWM in July 2022 recognized these problems and
5 decided to adopt the language regarding DC chargers.

6 The opposing arguments would be, first, that there are, in fact, some AC chargers that have the Indication of Delivery
7 on their face – but these are limited and much more expensive. Second, that the industry could have anticipated the
8 requirement; however, no state formally adopted HB 44 until FL did so in legislation in February 2021 – and even
9 that legislation delayed the adoption further, until the NTEP certification program was put in place in November 2021.

10 The submitter requested that this be a Voting item in 2023.

11 **Comments in Favor:**

12 **Regulatory:**

- 13 •

14 **Industry:**

- 15 •

16 **Advisory:**

- 17 •

18 **Comments Against:**

19 **Regulatory:**

- 20 •

21 **Industry:**

- 22 •

23 **Advisory:**

- 24 •

25 **Neutral Comments:**

26 **Regulatory:**

- 27 •

28 **Industry:**

- 29 •

30 **Advisory:**

- 31 •

32 **Item Development:**

33 New

34 Additional letters, presentation and data may have been submitted for consideration with this item. Please refer to
35 www.ncwm.com/publication-15 to review these documents.

EVF-23.2	
Regional recommendation to NCWM on item status:	
<input type="checkbox"/>	Recommend as a Voting Item on the NCWM agenda
<input type="checkbox"/>	Recommend as an Information Item on the NCWM agenda
<input type="checkbox"/>	Recommend as an Assigned Item on the NCWM agenda <i>(To be developed by an NCWM Task Group or Subcommittee)</i>
<input type="checkbox"/>	Recommend as a Developing Item on the NCWM agenda <i>(To be developed by source of the proposal)</i>
<input checked="" type="checkbox"/>	Recommend Withdrawal of the Item from the NCWM agenda <i>(In the case of new proposals, do not forward this item to NCWM)</i>
<input type="checkbox"/>	No recommendation from the region to NCWM <i>(If this is a new proposal, it will not be forwarded to the national committee by this region)</i>
Comments and justification for the regional recommendation to NCWM: (This will appear in NCWM reports)	
The following comments were received during the 2022 SWMA Annual Meeting:	
Mr. Prince, State of Florida, stated that this has been addressed and the item should be withdrawn.	
Ms. Goudy of Electrify America stated that this would modify a brand-new proposal and should be withdrawn.	
The SWMA S&T Committee recommends this item be Withdrawn.	

1

2 **EVF-23.3 S.2.7. Indication of Delivery**

3 **Source:**
4 Power Measurements LLC

5 **Purpose:**
6 Reduce the exemption for DC EVSE from 2028 to 2025.

7 **Item under Consideration:**
8 Amend Handbook 44, Electric Vehicle Fueling Systems as follows:

9 **S.2.7. Indication of Delivery.** – The EVSE shall automatically show on its face the initial zero condition and
10 the quantity delivered (up to the capacity of the indicating elements). All DC EVSE are exempt from this
11 requirement until January 1, ~~2028~~2025.

12 **Previous Action:**
13 New item in 2023

14 **Original Justification:**
15 The requirement for a display has been in the code since its inception in 2016. On December 31, 2015 (just before
16 HB44 3.4 was published with tentative status) there were only 2,377 DC EVSE installed. Of these 1,790 were from
17 a single provider, Tesla. By December 31, 2017 (two years after the code was published) there were only 3,708 DC
18 EVSE of which 2,883 were Tesla. At that point in time the only manufacturer not producing EVSE which complied
19 with the display requirement in S.2.7 was Tesla. They remain the only noncompliant supplier today, seven years after
20 the code was initially published. There is no technological reason for Tesla not to provide a display on their EVSE.

21 People have argued that retrofitting DC EVSE with displays would be extremely expensive. First manufacturers have
22 had seven years to comply with the display requirement. All but one have complied. Non-compliance was a conscious
23 business decision to ignore the requirement. Second, Tesla generally places multiple chargers at each location and at

1 each location has a data/control device for the entire installation. Since HB44 allows a single information kiosk for
2 multiple EVSE it would be quite economical to put in a single display pedestal for all EVSE installed at a single
3 location.

4 Tesla has an elegant customer experience where the charging transaction is authorized and all of the information
5 desired by the customer is displayed on the vehicle's display. That provides a good driver experience but does not
6 allow testing of the EVSE as per the Handbook. Tesla has recently announced that it intends to begin offering charging
7 to non-Tesla EVSE. Those vehicles will not have access to the data provided on a Tesla display.

8 The submitter requested that this be a Voting item in 2023.

9 **Comments in Favor:**

10 **Regulatory:**

- 11 •

12 **Industry:**

- 13 •

14 **Advisory:**

- 15 •

16 **Comments Against:**

17 **Regulatory:**

- 18 •

19 **Industry:**

- 20 •

21 **Advisory:**

- 22 •

23 **Neutral Comments:**

24 **Regulatory:**

- 25 •

26 **Industry:**

- 27 •

28 **Advisory:**

- 29 •

30 **Item Development:**

31 New

32 Additional letters, presentation and data may have been submitted for consideration with this item. Please refer to
33 www.ncwm.com/publication-15 to review these documents.

EVF-23.3	
Regional recommendation to NCWM on item status:	
<input type="checkbox"/> Recommend as a Voting Item on the NCWM agenda <input type="checkbox"/> Recommend as an Information Item on the NCWM agenda <input type="checkbox"/> Recommend as an Assigned Item on the NCWM agenda <i>(To be developed by an NCWM Task Group or Subcommittee)</i> <input type="checkbox"/> Recommend as a Developing Item on the NCWM agenda <i>(To be developed by source of the proposal)</i> <input checked="" type="checkbox"/> Recommend Withdrawal of the Item from the NCWM agenda <i>(In the case of new proposals, do not forward this item to NCWM)</i> <input type="checkbox"/> No recommendation from the region to NCWM <i>(If this is a new proposal, it will not be forwarded to the national committee by this region)</i>	
Comments and justification for the regional recommendation to NCWM: <i>(This will appear in NCWM reports)</i>	
The following comments were received during the 2022 SWMA Annual Meeting:	
Mr. Prince, State of Florida, stated that this has been addressed and the item should be withdrawn.	
Ms. Goudy of Electrify America stated that this item would modify a brand-new proposal and it should be withdrawn.	
The SWMA S&T Committee recommends this item be Withdrawn.	

1

2 **EVF-23.4 S.5. Markings, and N.5. Test of an EVSE System.**

3 **Source:**
 4 Power Measurements LLC

5 **Purpose:**
 6 Update the details of the recommended tests in HB44 3.40 to better conform to current practice and Pub 14
 7 instructions.

8 **Item under Consideration:**
 9 Amend Handbook 44, Electric Vehicle Fueling Systems as follows:

10 **S.5. Markings.** – The following identification and marking requirements are in addition to the requirements
 11 of Section 1.10. General Code, paragraph G-S.1. Identification.

12 **S.5.1. Location of Marking Information; EVSE.** – The marking information required in General Code,
 13 paragraph G-S.1. Identification shall appear as follows:

14 (a) within 60 cm (24 in) to 150 cm (60 in) from ground level; and

15 (b) on a portion of the EVSE that cannot be readily removed or interchanged (e.g., not on a service
 16 accesspanel).

17 **S.5.2. EVSE Identification and Marking Requirements.** – In addition to all the marking requirements
 18 of Section 1.10. General Code, paragraph G-S.1. Identification, each EVSE shall have the following
 19 information conspicuously, legibly, and indelibly marked:

20 (a) voltage rating;

- 1 (b) maximum-~~current~~ deliverable amperes;
- 2 (c) type of current (AC or DC or, if capable of both, both shall be listed);
- 3 (d) minimum measured quantity (MMQ); and
- 4 (e) temperature limits, if narrower than and within – 40 °C to + 85 °C (– 40 °F to + 185
- 5 °F).(Amended 2021)

6 **S.5.3. Abbreviations and Symbols.** – The following abbreviations or symbols may appear on an EVSE
7 system.

- 8 (a) VAC = volts alternating current;
- 9 (b) VDC = volts direct current;
- 10 (c) MDA = maximum deliverable amperes;
- 11 (d) ~~J=joule~~Wh – kilowatt hours.

12 And

14 **N.5. Test of an EVSE System.**

15 **N.5.12. Performance Verification in the Field.** – Testing in the field is intended to validate the transactional
16 accuracy of the EVSE system. **Provided the EVSE under test has a valid type approval certificate, then t**~~t~~
17 **he following testing is deemed sufficient for a field validation.**

18 **(1) For AC EVSE**

- 19 **(i) A point between 10 % and 20 % of the maximum deliverable amperes, but not exceeding 8 A;**
- 20
- 21 **(ii) A point between 45 % and 55 % of the maximum deliverable amperes; and**
- 22
- 23 **(iii) A point between 70 % and 100 % of the maximum deliverable amperes.**

24 **(2) For DC EVSE**

- 25 **(i) A point at less than 30 A**
- 26
- 27 **(ii) A point between 20 % and 100 % of the maximum deliverable amperes with guidance to test**
at the maximum power level that is possible using the test equipment available.

28 **For DC systems it is anticipated that an electric vehicle may be used as the test load. Under that**
29 **circumstance, testing at the load presented by the vehicle shall be sufficient provided that it is greater than**
30 **20 % of the maximum deliverable amperes.**

31 All DC EVSE are exempt from this requirement until January 1, 2028.

32 (Amended 2023)

33 **N.5.21. Laboratory Accuracy Testing.** – The testing methodology compares the total energy delivered in a
34 transaction and the total cost charged as displayed/reported by the EVSE with that measured by the measurement
35 standard. **Each test shall be performed for at least the minimum measured quantity (MMQ).**

1 (a) For AC systems:

2 (1) ~~Accuracy tests of the EVSE system at a load of not less than 85 % of the maximum deliverable~~
 3 ~~amperes (expressed as MDA) as determined from the pilot signal for a total energy delivered of at~~
 4 ~~least twice the minimum measured quantity (MMQ). If the MDA would result in maximum~~
 5 ~~deliverable power of greater than 7.2 kW, then the test may be performed at 7.2 kW. Shall be~~
 6 ~~performed at the following current levels:~~

7 (i) A point between 10 % and 20 % of the maximum deliverable amperes, but not
 8 exceeding 8A;

9 (ii) A point between 45 % and 55 % of the maximum deliverable amperes; and

10 (iii) A point between 70 % and 100 % of the maximum deliverable amperes.

11 ~~(2) Accuracy test of the EVSE system at a load of not greater than 10 % of the maximum~~
 12 ~~deliverable amperes (expressed as MDA) as determined from the pilot signal for a total energy~~
 13 ~~delivered of at least the minimum measured quantity (MMQ).~~

14 (b) For DC systems ~~(see note)~~ tests shall be performed at two voltage points one between 350 VDC
 15 and 400 VDC and if supported by the EVSE a second at between 700 VDC and 800 VDC:

16 (1) ~~Accuracy tests of the EVSE system at a load of not less than 85 % of the maximum deliverable~~
 17 ~~amperes current (expressed as MDA) as determined from the digital communication message~~
 18 ~~from the DC EVSE to the test standard for a total energy delivered of at least twice the~~
 19 ~~minimum measured quantity (MMQ). shall be performed at the following current levels:~~

20 (i) A point at less than 30A;

21 (ii) A point between 45 % and 55 % of the maximum deliverable amperes; and

22 (iii) A point between 70 % and 100 % of the maximum deliverable amperes.

23 (2) ~~Accuracy test of the EVSE system at a load of not more than 10 % of the maximum deliverable~~
 24 ~~amperes (expressed as MDA) as determined from the digital communication message from~~
 25 ~~the DC EVSE to the test standard for a total energy delivered of at least the minimum~~
 26 ~~measured quantity (MMQ). (2) Accuracy test of the EVSE system at a load of not more than~~
 27 ~~10 % of the maximum deliverable amperes (expressed as MDA) as determined from the digital~~
 28 ~~communication message from the DC EVSE to the test standard for a total energy delivered~~
 29 ~~of at least the minimum measured quantity (MMQ).~~

30 All DC EVSE are exempt from this requirement until January 1, 2028.

31 (Amended 2022 and 2023)

32 ~~Note: For DC systems it is anticipated that an electric vehicle may be used as the test load. Under that~~
 33 ~~circumstance, testing at the load presented by the vehicle shall be sufficient. Circumstance, testing at the~~
 34 ~~load presented by the vehicle shall be sufficient~~

36 **Previous Action:**
 37 New item in 2023

38 **Original Justification:**
 39 S.5.2

1 Change (b) to maximum deliverable amperes because that is the term to be used throughout the document. Previously
2 both terms had been used interchangeably.

3 S.5.3

4 Joule is no longer used in the document. Replace with the abbreviation for kilowatt hours.

5 N.5

6 When the HB44 code was originally written there had been no real experience in EVSE testing. Additionally, DC
7 EVSE were quite new and power levels were low (typically 50kW) by today's standards where 350 kW systems are
8 already deployed and megawatt systems are in discussion. The test points chosen at that time have been proven to be
9 less than optimum to verify performance of the EVSE. Publication 14, which was developed later than HB44 adopted
10 a set of test points similar to those proposed here. The tests proposed here have been extensively discussed in the
11 NIST EVSE Working Group. However, that Work Group ran out of time for a formal vote to approve these proposals.

12 As background, the NIST WG is submitting Form 15s to start the restructuring of the test process. In those Form 15s
13 the No Load and Starting load tests are removed from section 3.4. This proposal completes the restructuring of the
14 EVSE testing.

15 **Detailed review of proposed changes:**

16 Logically section 5.2.1 should follow section 5.2.2 so both sections have been renumbered.

17 **New 5.2.1**

18 In the new 5.2.1 (formerly 5.2.2) the word Laboratory was added to the title. As the power of both AC and DC EVSE
19 has grown rapidly the equipment to test them at full power has become both large and expensive. It is perfectly
20 reasonable for NTEP or a manufacturer to have this type of equipment but not reasonable for the average Weights and
21 Measures inspector to have it available in the field. For that reason, this proposal breaks testing into two types: (1)
22 testing for type verification done in a laboratory or at a manufacturer and (2) testing in the field for verification.

23 For testing AC systems in the laboratory three test points are proposed:

24(i) A point between 10 % and 20 % of the maximum deliverable amperes, but not exceeding 8A,

25(ii) A point between 45 % and 55 % of the maximum deliverable amperes,

26(iii) A point between 70 % and 100 % of the maximum deliverable amperes.

27 All test points are expressed in terms of a percent of the maximum deliverable amperes of the EVSE. For point (i) of
28 the test a restriction has been added to ensure that high current chargers are tested near the nominal 6 A load that is
29 the minimum charging current for most vehicles.

30 Today AC Level 2 chargers typically have maximum currents of 30 A to 80 A. Chargers with currents above 32 A
31 were generally unavailable at the time HB44 3.4 was written. Several vehicles have recently been introduced that
32 charge at 48 A. There is only one vehicle currently available that charges at 80 A. This test regime can be performed
33 quickly. It can be performed on any AC Level 2 EVSE with test equipment commercially available and in the hands
34 of multiple Weights and Measures authorities.

35 **New 5.2.2**

36 Since HB44 3.40 was initially written a whole new generation of DC chargers have been developed. At that time the
37 maximum power delivery was approximately 100 kW at 400 VDC. Today we have 350 kW systems operating at both
38 400 VDC and 800 VDC. The CCS EVSE standards have already been updated to allow chargers up to 1000 VDC
39 and 800 A (800 kW). Because there are now two broad classes of DC EVSE; 400 VDC and 800VDC two voltage test
40 points are included. Both voltage classes are capable of charging at 400V so a point between 350 VDC and 400VDC
41 is required for both. For systems that can also operate at 800VDC a second point between 700 VDC and 800 VDC is
42 required. Current points are to be tested at both voltages if they are appropriate for the EVSE.

43 For DC systems three test points are proposed:

- 1 (i) A point at less than 30 A
- 2 (ii) A point between 45 % and 55 % of the maximum deliverable amperes
- 3 (iii) A point between 70 % and 100 % of the maximum deliverable amperes

4 This approach provides a test point at the lower end of the power transfer range where older vehicles may charge or
 5 where more modern EVs charge when topping off. The other two points are intended to bracket the power levels
 6 where most EV transfer most of their energy.

7 The power levels of DC EVSE are rapidly evolving to ever higher levels. For that reason, this change provides for
 8 flexibility in field testing of DC EVSE at the high power point. The high current point is revised to 20% to 100% of
 9 the maximum deliverable current **with guidance to test at the maximum power level that is possible using the test**
 10 **equipment available. The new code also provides for using a vehicle as the test load providing it meets the 20%**
 11 **of maximum deliverable current requirement.**

12 One objection might be the creation of a field testing regime for DC EVSE that is less rigorous than that applied in
 13 the laboratory. For many decades ANSI C12 meter testing has applied testing over the full range of voltage and
 14 current for meters during type testing but only done validation testing at two current values. For example, class 320
 15 meters (320 A maximum current) are tested for accuracy at 11 points between 3 A and 320 A during type evaluation.
 16 However, for verification typically only two current points are used 5 A and 50 A.

17 Another objection might be the requirement to test 800 VDC EVSE at both 400 VDC and 800 VDC. Only a very few
 18 electric vehicles (three at this time) are capable of using 800 VDC charging. Therefore, even though an EVSE may be
 19 capable of 800 VDC operation because most EV operate at 400 VDC testing at 400 VDC on an 800 VDC capable
 20 system is appropriate.

21 The submitter requested that this be a Voting item in 2023.

22 **Comments in Favor:**

23 **Regulatory:**

- 24 •

25 **Industry:**

- 26 •

27 **Advisory:**

- 28 •

29 **Comments Against:**

30 **Regulatory:**

- 31 •

32 **Industry:**

- 33 •

34 **Advisory:**

- 35 •

36 **Neutral Comments:**

- 1 **Regulatory:**
- 2 •
- 3 **Industry:**
- 4 •
- 5 **Advisory:**
- 6 •

7 **Item Development:**
 8 New

9 Additional letters, presentation and data may have been submitted for consideration with this item. Please refer to
 10 www.ncwm.com/publication-15 to review these documents.

EVF-23.4	
Regional recommendation to NCWM on item status:	
<input type="checkbox"/> Recommend as a Voting Item on the NCWM agenda <input type="checkbox"/> Recommend as an Information Item on the NCWM agenda <input type="checkbox"/> Recommend as an Assigned Item on the NCWM agenda <i>(To be developed by an NCWM Task Group or Subcommittee)</i> <input type="checkbox"/> Recommend as a Developing Item on the NCWM agenda <i>(To be developed by source of the proposal)</i> <input checked="" type="checkbox"/> Recommend Withdrawal of the Item from the NCWM agenda <i>(In the case of new proposals, do not forward this item to NCWM)</i> <input type="checkbox"/> No recommendation from the region to NCWM <i>(If this is a new proposal, it will not be forwarded to the national committee by this region)</i>	
Comments and justification for the regional recommendation to NCWM: <i>(This will appear in NCWM reports)</i>	
The following comments were received during the 2022 SWMA Annual Meeting: Ms. Goudy of Electrify America stated that the test current is too low and recommended withdrawal. Dr. Curran, State of Florida, stated that line 17 on page 238 should read N.5.1. The SWMA S&T Committee recommends that this item be Withdrawn.	

- 11
- 12 **EVF-23.5 S.5.2. EVSE Identifications and Marking Requirements, N.5.2. Accuracy**
 13 **Testing, and T.2. ~~Load~~ Accuracy Test tolerances.**
- 14 **Source:**
 15 Power Measurements LLC
- 16 **Purpose:**
 17 Update the tolerances for DC EVSE and change the effective date to January 1, 2024. Make the new tolerance
 18 retroactive effective January 1, 2025.
- 19 **Item under Consideration:**
 20 Amend Handbook 44, Electric Vehicle Fueling Systems as follows:

1 **S.5.2. EVSE Identification and Marking Requirements.** – In addition to all the marking requirements of
 2 Section 1.10. General Code, paragraph G-S.1. Identification, each EVSE shall have the following information
 3 conspicuously, legibly, and indelibly marked:

- 4 (a) voltage rating;
- 5 (b) maximum current deliverable;
- 6 (c) type of current (AC or DC or, if capable of both, both shall be listed);
- 7 (d) minimum measured quantity (MMQ); ~~and~~
- 8 (e) temperature limits, if narrower than and within – 40 °C to + 85 °C (– 40 °F to + 185 °F).(Amended
 9 2021), and
- 10 **(f) For EVSEs subject to a tolerance of 5% (see paragraph T.2.1.) a notice shall be conspicuously,**
 11 **legibly, and indelibly displayed, in a position plainly visible to a person accessing a charging port**
 12 **of the EVSE which states:**

13 **NOTICE:**

14 **“This charger operates at a tolerance of 5 percent versus**
 15 **chargers which operate at a tolerance of 2 percent.”**

16 **EVSEs subject to a tolerance of 1 % Acceptance and 2% Maintenance Tolerance are not**
 17 **required to be marked with such a statement.**

18 And

19 **N.5.2. Accuracy Testing.** – The testing methodology compares the total energy delivered in a transaction
 20 and the total cost charged as displayed/reported by the EVSE with that measured by the measurement
 21 standard.

- 22
- 23
- 24 (b) For DC systems (see note):
- 25
- 26 (1) Accuracy test of the EVSE system at a load of not less than 85 % of the maximum deliverable
 27 amperes current (expressed as MDA) as determined from the digital communication message
 28 from the DC EVSE to the test standard for a total energy delivered of at least twice the
 29 minimum measured quantity (MMQ).
- 30
- 31 (2) Accuracy test of the EVSE system at a load of not more than 10 % of the maximum deliverable
 32 amperes (expressed as MDA) as determined from the digital communication message from
 33 the DC EVSE to the test standard for a total energy delivered of at least the minimum measured
 34 quantity (MMQ).
- 35

36 **All DC EVSE are exempt from this requirement until January 1, 2028.**

37 And

38 T.2. ~~Load Accuracy~~ Test Tolerances.

39 T.2.1. EVSE ~~Load Accuracy~~ Test Tolerances. – The tolerances for EVSE ~~load accuracy tests for all AC~~
 40 **EVSE and for DC EVSE installed on or after January 1, 2025 are:**

1 (a) Acceptance Tolerance: 1.0 %; and

2 (b) Maintenance Tolerance: 2.0 %.

3 **For DC EVSE installed prior to January 1, 2025 tolerances for the accuracy tests are:**

4 (a) **Acceptance Tolerance: 5.0 %; and**

5 (b) **Maintenance Tolerance: 5.0 %.**

6 **All DC EVSE are exempt from this requirement until January 1, 2028.**

7 (Amended 2022)

8 **Original Justification:**

9 This topic has been discussed in the NIST Working Group numerous times. Most recently it appeared that the group
10 was obtaining consensus on the language presented here. Industry has reported that their testing of existing systems
11 suggests that they would comply with the proposed error limits of +/- 5% without requiring any infield upgrades.
12 Since thousands of new DC EVSE are planned under current Federal programs it is very important to have some
13 known level of accuracy for all EVSE in the field. The 5% level for all systems installed prior to January 1, 2025 is
14 a reasonable approach that should have no negative effects on the industry. Delaying a specified accuracy to 2028
15 opens the market up to inequities and fraud.

16 This proposal has significant financial advantage to industry. Under it all systems installed before January 1, 2025
17 would be permanently grandfathered in at the +/- 5% tolerance levels until they were retired or had a repair which
18 required recertification.

19
20 The time frame discussed most recently in the NIST WG was for this change to be effective January , 2024. That was
21 to some extent predicated on getting this change into the code in 2023. In this submission the date has been delayed
22 to January 1, 2025 to allow everyone to be fully prepared for its implementation.

23 The principal argument made against this requirement has been that systems cannot be made to comply in a reasonable
24 time or for a reasonable amount of investment. More recent testing of existing systems has shown that with the relaxed
25 tolerance of +/- 5% the vast majority of systems already installed would qualify.

26 The submitter requested that this be a Voting item in 2023.

27 **Comments in Favor:**

28 **Regulatory:**

- 29 •

30 **Industry:**

- 31 •

32 **Advisory:**

- 33 •

34 **Comments Against:**

35 **Regulatory:**

- 36 •

37 **Industry:**

- 38 •

1 **Advisory:**

- 2 •

3 **Neutral Comments:**

4 **Regulatory:**

- 5 •

6 **Industry:**

- 7 •

8 **Advisory:**

- 9 •

10 **Item Development:**

11 New

12 Additional letters, presentation and data may have been submitted for consideration with this item. Please refer to
 13 www.newm.com/publication-15 to review these documents.

EVF-23.5	
Regional recommendation to NCWM on item status:	
<input type="checkbox"/>	Recommend as a Voting Item on the NCWM agenda
<input type="checkbox"/>	Recommend as an Information Item on the NCWM agenda
<input type="checkbox"/>	Recommend as an Assigned Item on the NCWM agenda <i>(To be developed by an NCWM Task Group or Subcommittee)</i>
<input type="checkbox"/>	Recommend as a Developing Item on the NCWM agenda <i>(To be developed by source of the proposal)</i>
<input checked="" type="checkbox"/>	Recommend Withdrawal of the Item from the NCWM agenda <i>(In the case of new proposals, do not forward this item to NCWM)</i>
<input type="checkbox"/>	No recommendation from the region to NCWM <i>(If this is a new proposal, it will not be forwarded to the national committee by this region)</i>
Comments and justification for the regional recommendation to NCWM: (This will appear in NCWM reports)	
The following comments were received during the 2022 SWMA Annual Meeting:	
Mr. Prince, State of Florida, stated that this issue has been addressed and that this item should be withdrawn.	
Ms. Goudy of Electrify America stated that this item should be withdrawn.	
The SWMA S&T Committee recommends that this item be Withdrawn.	

14

15 **EVF-23.6 S.5.2. EVSE Identification and Marking Requirements., and T.2.**
 16 **Tolerances.**

17 **Source:**

18 Florida Department of Agriculture and Consumer Services; Electrify America; Tesla; EVGo, Siemens

19 **Purpose:**

20 The revised proposal would amend Handbook 44, Section 3.40 Tentative Code in the following ways:

1 Paragraph T.2.1 would be revised for DC chargers. The 1% (acceptance) / 2%
2 (maintenance) tolerances would apply to devices installed after January 1, 2024. For
3 devices installed before that date, the tolerances would be 5% (acceptance and maintenance).

4 2. For the sake of clarity and transparency for customers and inspectors, a device subject to the
5 5% tolerance would have to be marked as such. The proposal would require specific language
6 for the marking.

7 3. If a manufacturer has achieved 1%-capable chargers earlier than the January 2024 timeframe,
8 users of those chargers might prefer not to mark the chargers as 5% chargers; and then those
9 chargers would be subject to the 1%/2% tolerance. The proposal includes language to establish this
10 treatment.

11 4. The 5% tolerance for pre-2024 chargers would end on January 1, 2024. After that date, all DC
12 chargers would be subject to the 1% (acceptance) / 2% (maintenance) tolerance.

13 **Item under Consideration:**

14 Amend Handbook 44, Electric Vehicle Fueling Systems as follows:

15 **S.5.2. EVSE Identification and Marking Requirements.** – In addition to all the marking requirements
16 of Section 1.10. General Code, paragraph G-S.1. Identification, each EVSE shall have the following information
17 conspicuously, legibly, and indelibly marked:

- 18 (a) voltage rating;
19 (b) maximum current deliverable;
20 (c) type of current (AC or DC or, if capable of both, both shall be listed);
21 (d) minimum measured quantity (MMQ); and
22 (e) temperature limits, if narrower than and within – 40 C to + 85 C (– 40 F to + 185 F).

23
24 **S.5.2.1. Marking of Accuracy Limits, DC EVSEs Installed Prior to 2024. – A DC EVSE installed prior**
25 **to 2024 shall be marked with the following unless it is certified to the tolerances of T.2.2(b):**

26 **NOTICE:**

27 **“This charger operates at a tolerance of up to +/- 5 percent versus other chargers which operate at a**
28 **tolerance of up to +/- 2 percent.”**

29
30 **This marking shall be conspicuously and legibly displayed in a position plainly visible to a person**
31 **accessing a charging port of the EVSE.**

32
33 **(Added 202X)**

34
35 T.2. Test Tolerances.

36
37 T.2.1. EVSE Load **Accuracy** Test Tolerances for **AC Systems**. – The tolerances for EVSE load tests
38 **for AC systems** are:

- 39 (a) Acceptance Tolerance: 1.0 %; and
40 (b) Maintenance Tolerance: 2.0 %.

41
42 **T.2.2 EVSE Load Accuracy Test Tolerances for DC Systems. -- The tolerances for EVSE load tests on**
43 **DC systems shall be as follows:**

44
45 **(a) For DC systems installed prior to January 1, 2024, and that bear the notice specified in**
46 **paragraph S.5.2.1. Marking of Accuracy Limits, DC EVSEs Installed Prior to 2024, acceptance**

and maintenance tolerances are: 5.0 %. This paragraph T.2.2(a) shall expire on January 1, 2034; after that date, all DC EVSEs shall be subject to the tolerances of paragraph T.2.2(b).

(b) For DC systems installed on or after January 1, 2024, or that do not bear the notice specified in paragraph S.5.2.1. Marking of Accuracy Limits, DC EVSEs Installed Prior to 2024 tolerances are:

(1) Acceptance Tolerance: 1.0 %; and

(2) Maintenance Tolerance: 2.0 %.

All DC EVSE are exempt from this requirement **paragraph T.2.2** until January 1, 2028.

Previous Action:

(New item in 2023)

Original Justification:

A. The effect of the proposed revisions

The changes we propose would work as follows: All DC chargers would remain exempt from the accuracy tolerances until January 1, 2028, as NCWM adopted at the 2022 annual meeting. When accuracy tolerances come into force, a DC charger installed after January 1, 2024, would have to satisfy the 1% (acceptance) / 2% (maintenance) tolerance, the same levels as for AC chargers. But a DC charger installed before January 1, 2024, would have to meet only a 5% accuracy tolerance. That 5% accuracy tolerance would expire on January 1, 2034, at which point all the legacy chargers will have to have been retrofitted or replaced.

The proposal would require a charger that is subject to the 5% tolerance to display a marking, with specified language, informing customers and inspectors of that fact. But the proposal leaves open the possibility that a given manufacturer might achieve the 1%/2% tolerance earlier, and then would specify that capability for a given model. Devices in that model would not have to be marked as 5% devices; but if they are not marked that way, they would of course be subject to the 1%/2% level as for new chargers.

B. The basic justification

DC and AC chargers are fundamentally different—in technology, in customer use, and in metering capabilities. AC charging technology, the older form, delivers energy in the same form—voltages and currents oscillating at 60 Hertz (in the United States) as utilities have provided it for a century. Because a vehicle has to convert AC energy to DC for charging the battery, AC charging stations operate at no more than 19.7 kW, and most no more than 6-7 kW. These charging rates will add 24-80 miles of range in an hour of charging a typical car, and consequently AC charging involves extended sessions—the median time that a customer uses an AC station is 22 hours.¹ The voltages delivered are no more than 480 volts ac, and the current is no more than 50 amps ac (and more typically 30 amps ac). By contrast, DC chargers deliver energy in the same form that a battery ultimately needs it. Using voltages of 400 to 950 volts dc and currents up to 500 amps dc (higher levels are coming in the future for applications like charging heavy trucks), they are able to deliver 50kW, 150 kW, 350 kW, or higher charging rates. These stations will add 200-1400 miles of range in an hour of charging, or, more meaningfully, 400 miles of range in as little as 20 minutes. A customer at a DC station will arrive, charge briefly, and then depart. Customers incorporate AC chargers into their regular routines, such as by driving to work and charging there. DC chargers are more commonly used to support long-distance trips.²

1 ¹ Idaho National Laboratory, “Plugged In: How Americans Charge Their Electric Vehicles,” p.14,
2 <https://avt.inl.gov/sites/default/files/pdf/arra/PluggedInSummaryReport.pdf>.

3 ² As the California Energy Commission has explained, “it is therefore useful to treat infrastructure for
4 interregional travel (predominantly DCFCs) differently from infrastructure for intraregional travel
5 (predominantly Level 1 and Level 2 chargers).”
6 <https://efiling.energy.ca.gov/GetDocument.aspx?tn=233986&DocumentContentId=66805> at page 14.

7 For AC charging, manufacturers have been able to utilize metering technology that has been developed
8 over a century for electric utilities. When Handbook 44, section 3.40 was developed in 2015, that AC
9 metering technology was well understood. There have been long-established standards for AC revenue
10 meters—though those standards, in the utility sector, are not necessarily the same in every respect as how
11 a weights and measures standard would work. One indication of the relatively mature state of AC metering
12 is that NIST has long provided ordinary-course calibration services for AC watt-hour meters that operate
13 at 60 Hertz, within ranges of 69 to 480 volts and 0.5 to 30 amps (sufficient to cover typical AC chargers).³
14 DC metering technology, by contrast, has been “in research and development.”⁴ When section 3.40 was
15 adopted, the accuracy tolerances of 1.0% (acceptance) and 2.0% (maintenance) were predictive and
16 aspirational for DC chargers. As of November 2019, when California adopted its own regulation based
17 on section 3.40, meters and chargers meeting that standard were not yet generally commercially
18 available.⁵ Meanwhile, NIST calibration services for DC watt-hour meters are non-standard, and are
19 available only up to 240 volts and 5 amps⁶—far below the levels needed for testing DC chargers.

20 Argonne National Lab has studied the availability of DC metering technology. Our understanding is
21 that its draft report (not yet finalized, so far as we are aware) concludes that there are now on the market
22 (at least in principle) meters for use in DC chargers that can meet a 1% acceptance / 2% maintenance
23 tolerance. It is reasonable to conclude that the 1% / 2% tolerance will be achievable in general. The
24 current proposal is focused on how to handle the chargers that are installed before that point. Previously
25 installed chargers will not in general be able to satisfy a 1% / 2% accuracy tolerance. To be clear, we do
26 not suggest that every existing charger would be more than 2% inaccurate. Indeed, it would not genuinely
27 be possible to make that assessment, given the lack of NIST-traceable measurement apparatus to test
28 fast DC chargers in the field.

29 There is presumably a distribution of potential deviations among devices in the field. Given what
30 metering technology has been commercially available, a 2% maintenance accuracy would lead to
31 inspection problems for a high proportion of devices.

32 The proposal would establish a tolerance of 5% for devices installed before January 1, 2024. The
33 justification for this particular choice of tolerance and timeline is as follows:

34 1. In 2019, California adopted a regulation that put a modified version of section 3.40 into
35 force for new devices. DC chargers installed before January 2023 are subject to no weights and measures
36 standards at all until 2033. DC chargers installed after January 2023 (and before January 2033) are subject
37 to a maintenance tolerance of 5.0% (and acceptance tolerance of 2.5%). Consequently, in California, which
38 represents roughly 30% of the currently-existing base of DC chargers, the maintenance tolerance will be
39 5.0% for the coming decade. A maintenance tolerance of 5.0% for legacy chargers in section 3.40 will be
40 stricter overall than the California regulation (because it will apply to all legacy chargers, whereas the
41 California standard applies only to post-2023 chargers), but will align with the numerical tolerance used
42 in California. Although a 5.0% tolerance is

44 ³ https://shop.nist.gov/ccrz___ProductDetails?sku=56200C&cclcl=en_US.

45 ⁴ Cal. Dep’t of Food & Agriculture, Final Statement of Reasons on Electric Vehicle Fueling
46 Systems, p.23 (Nov. 1, 2019).

1 ⁵ *Id.*

2 ⁶ https://shop.nist.gov/ccrz___ProductDetails?sku=56110S&cclcl=en_US.

3 among the larger tolerances used in Handbook 44, it is not unprecedented. And the fact that newchargers
4 in California will be subject to that standard will mean EV charging customers have substantial
5 experience with that chargers at that tolerance, and the 5.0% tolerance we propose would be the same
6 transactional experience as customers in California (the largest EV charging market in the country)
7 receive. It bears mention, too, that as Measurement Canada prepares to implement standards for AC
8 chargers, the tolerance (acceptance and maintenance) will be 3.0%, not the 1% acceptance in Handbook
9 44. The cost of a typical charging session is \$15 to \$20. A 5.0% maintenance standard would mean a
10 variation, beyond that, of an additional plus *or minus* 40 cents. As with any tolerance, that variation
11 could at any given charger be for or against either side to the transaction.

12 2. The industry submitters have studied carefully their existing chargers, measurement devices
13 and existing models now available. They believe the 5% maintenance tolerance is achievable at a
14 manageable cost in the future, because it will generally not require extensive reconfiguring of cabinets
15 and the installation of four-wire cables.

16 3. The cost of bringing legacy chargers into line with the 1%/2% standard would be extreme.
17 Although equipment is not available to test DC fast chargers in the field, some operators have found in
18 tests of existing devices that they can be brought to a 5% tolerance, but cannot meet the 1%/2% standard
19 without replacing the meters or implementing an entirely new measurement system, which means a
20 physical reconfiguration at each station and/or replacing the cables for delivering the energy to vehicles.
21 Section 3.40 standards are based on the energy delivered at the connector to the car; in other words, a
22 charger must account for losses in the cables. The most straightforward way to account for losses is to
23 measure the voltage at the vehicle connector; that means the cable must have two additional high-voltage
24 leads, to carry that voltage back to the meter.⁷ In California’s Initial Statement of Reasons (ISOR) for
25 adopting specifications and tolerances requirement for commercial EVSE, California estimated that it
26 costs approximately

27 \$20,000 to retrofit an existing DC charger.⁸ We understand that cost to represent the cost (parts and
28 labor) to replace the charging cable, and possibly to replace the meter if that task is simple. This cost
29 may be a significant underestimate for some models of charger, because replacing the meter may not
30 always be possible without physical reconfiguration of the space within the charger. Which charger
31 models would require that sort of reconfiguration, and what proportion of the installed base they
32 represent, is impossible to know without a detailed model-by-model study and detailed model-by-model
33 installation data across manufacturers. The upper end of cost would be simply the cost of replacing a
34 charger, which many operators would find preferable to physical reconfiguration of charger internals
35 anyway. The International Council on Clean Transportation (“ICCT”) reported in 2019 that fast DC
36 chargers cost between \$75,000 and \$140,000 per charger, for the charger itself.⁹ Installation costs range
37 from \$18,000 per charger (for six 150 kW chargers

39 ⁷ Charging cables are themselves complex objects, with liquid coolant and high-voltage
40 insulation. Cables for fast DC chargers that include additional high-voltage sensing leads were
41 not available in 2015.

42 ⁸ https://www.cdfa.ca.gov/dms/pdfs/regulations/EVSE_ISOR.pdf.

43 ⁹ Michael Nicholas, “Estimating electric vehicle charging infrastructure costs across major U.S. metropolitan
44 areas,” ICCT Working Paper 2019-14, p.2 tab. 2 (Aug. 2019),
45 https://theicct.org/sites/default/files/publications/ICCT_EV_Charging_Cost_20190813.pdf.

1 at a site) to \$65,000 per charger (for one 350 kW charger at a site).¹⁰ The total cost (installation and
2 equipment) for a 4-charger site would be roughly \$720,000. That said, some amount of the installation
3 cost represents upgrades to electrical supply lines and basic site construction, costs that would not be
4 incurred anew to replace equipment. So for a rough estimate, it is appropriate to use the lowest cost
5 estimate from the ICCT, which is \$17,692 (the cost per charger for a large site of 50 kW chargers). With
6 that figure, replacing a 4-charger site of 350 kW chargers would cost roughly \$630,000, or \$157,000 per
7 charger.

8 4. Based on data on the existing charge base from the National Renewable Energy Laboratory’s
9 Alternative Fuels Data Center (“AFDC”), we can assume there will be about 36,000 “pre-2024” DC
10 chargers.¹¹ These are only a fraction of the overall chargers that will be installed nationwide over the
11 coming decade, but bringing them into compliance with a 1%/2% tolerance will be highly costly. Taking
12 out the 30% that are in California (which already has regulations with a 5.0% maintenance tolerance,
13 for all post-2023 DC chargers), retrofitting all of those at the \$20,000 cost would total \$720 million. If
14 meter replacement is not possible and those chargers must all be replaced, the total would be \$5.6 billion.
15 The actual cost of bringing the pre-2024 chargers to compliance with a 2.0% maintenance tolerance
16 would be somewhere between these numbers.¹²

17 5. The January 2024 date moves faster than the California regulation. Under the California
18 regulation, the 1% / 2% tolerance would not come into force until 2033. It appears that meters capable
19 of that tolerance are now available on the market. The submitters propose January 2024 as the date for
20 distinguishing “legacy” from “new” chargers, because the existence of these meters on the market is not
21 all that is needed. Manufacturers have to access the meters, design products incorporating them; revise
22 production lines; test the new products to ensure they are safe and reliable; and obtain third-party
23 certifications (such as from Underwriters Laboratory) of the revised products. After those steps, a
24 manufacturer can begin delivering a revised product to operators. Installation of a charger is not simply
25 a matter of placing it on a counter; charging sites involve construction work, leading to the secure
26 attachment of a charger to a specially built concrete pad. In other words, from the first delivery of a
27 new model of charger to the first installations of those chargers also takes time. The January 2024 date
28 is appropriate for expecting new chargers to incorporate meters that were available a few years before
29 that date.
30

31 ¹⁰ *Id.* at 4 tab. 4.

32 ¹¹ According to the AFDC’s station locator database, there are 6,580 DC stations with 22,767
33 chargers. The AFDC also reports that the number of DC ports grew 29% year-on-year to the
34 second quarter of 2021. [https://afdc.energy.gov/files/u/publication/
35 electric_vehicle_charging_infrastructure_trends_second_quarter_2021.pdf](https://afdc.energy.gov/files/u/publication/electric_vehicle_charging_infrastructure_trends_second_quarter_2021.pdf). With
36 growth at this rate, about 6,600 additional DCFC stations will be installed in 2022 and 2023,
37 leading to a total of about 36,000 DC chargers that would be “pre-2024” chargers under the
38 proposal.

39 ¹² A charger that is not qualified for a given tolerance level may well be within the bounds of the tolerance,
40 because there is some distribution in metering performance. Even if devices are replaced only after
41 inspection, a significant fraction would need replacement, thus incurring this scale of cost. Moreover, it
42 might be most sensible for an operator to ensure all its devices are qualified, rather than waiting to see what
43 the results of inspection might be for a given charger.

44 6. The proposal focuses on installation before January 2024, rather than using the concept of
45 retroactive/non-retroactive that is more common in Handbook 44, because non-retroactive is ordinarily
46 based on when a device is placed in service. Many states do not yet regulate EV chargers and
47 consequently have no placed-in-service process. In these states, “placed in service” would not be a well-
48 defined concept, and regulators might not have good ways to determine when a device was placed in
49 service. Installation is a reasonably well-defined process, and it should be possible to identify when a

1 given charger was installed. California's regulation has differing status for pre-2023 and post-2023
2 chargers, and it bases that line on installation.
3

4 7. The proposal also specifies 5.0% as the acceptance tolerance, not just the maintenance
5 tolerance. As a practical matter in field inspections, the acceptance tolerance for pre-2024 chargers will
6 not be important. Section 3.40 (as amended at the 2022 NCWM meeting) exempts DC chargers from
7 the accuracy tolerance until 2028. When they become subject to accuracy tolerances, no pre-2024
8 charger will be at the point of acceptance. The proposal specifies an acceptance tolerance for clarity
9 in type evaluations, which ordinarily evaluate device models against the applicable acceptance
10 tolerance.

11 8. The exemption until 2028 adopted at the 2022 meeting does not eliminate the need for this
12 proposal. When DC chargers are subject to accuracy tolerance requirements, pre-2024 chargers will still
13 need to meet the applicable tolerance or be retrofitted or replaced. The 2028 time frame is unreasonably
14 soon to do that, given the cost estimates above. California estimated that chargers have an effective 10-
15 year lifespan.¹³ This estimate is highly uncertain, in part because it was based in part on older AC
16 chargers. Newer DC chargers, using more advanced technology for significantly more expensive
17 equipment, are likely to have usable lifetimes greater than 10 years. The proposal recognizes that,
18 nonetheless, there is a tradeoff between the cost of retrofitting or replacing devices, and the value of
19 tighter tolerances. Some number of chargers will fail and need replacement earlier than 10 years, thus
20 reducing the number that eventually need to be retrofitted or replaced to comply with tighter accuracy
21 tolerances. Overall, the proposal uses the same 10- year period that several states have already adopted.¹⁴
22 Notably, the effect is significantly more stringent than in the California regulation. Under California's
23 rule, a charger installed before 2023 is subject to no standards for 10 years, and then becomes subject
24 to standards in 2033; a replacement of the charger in 2032 would be subject to the 5.0% maintenance
25 tolerance. A charger installed in 2023 (and that hypothetical 2032 installation) would be subject to the
26 5.0% tolerance indefinitely, with no end point. Our proposal, by contrast, would make a pre-2024 charger
27 subject to the 5.0% tolerance once the 2028 compliance dates kicks in but only until 2034, at which point
28 the charger would have to be retrofitted, replaced, or otherwise brought to the 1%/2% tolerance.

29 **C. Potential objections**

30 In response to the industry's original proposal, some people commented that AC and DC chargers should
31 be treated the same. As explained above, they are not the same, not only because of technology differences
32 but also because customers use them and view them differently. California
33

34 ¹³ Cal. Dep't of Food & Agriculture, Final Statement of Reasons, p.6.

35 ¹⁴ 4 Cal. Code of Regulations § 4002.11; Rev. Code Wash. § 19.94.190(6).

36 and NTEP have distinguished AC and DC chargers since at least 2021, and NCWM has already
37 recognized important differences between them, in Handbook 44.

38 Some have also commented that there should not be parallel accuracy classes for a given application. But this
39 approach is not unprecedented. In 1986, NCWM required new scales to be marked with an accuracy class. Pre-
40 1986 scales could remain unmarked, and those unmarked scales were subject to various accuracy tolerances
41 (depending on application) that ranged up to 5.0%, compared to the largest tolerance for any marked scale at 2.0%.
42 For grain moisture meters, Handbook 44 has completely separate sections for pre-1998 and post-1998 devices, with
43 some different tolerance specifications for older and newer devices. For both scales and grain moisture meters, there
44 was no sunset date; the older devices have been allowed to continue in use for as long as they operated. We do not
45 suggest that the circumstances with EV chargers are the same. Each of those past examples was based on
46 justifications particular to that situation. Nonetheless, these examples show that it has been done to maintain parallel

1 tolerances for a given application. In addition, there are already parallel, differing tolerances for EV chargers. If
2 the proposal is not adopted, pre-2023 chargers in California will have no tolerance at all until 2033; post-2023
3 chargers will have a 5.0% maintenance tolerance for the indefinite future; and chargers elsewhere in the country,
4 including in states neighboring California, will have the existing Handbook 44 tolerances. The proposal shifts the
5 line between differing tolerances, but the situation of differing tolerances for the same application is already in place
6 without the proposal.

7

8 There have been claims that some manufacturers may be able to achieve 1% devices (DC chargers) before January
9 2024, and one or more may already have done so. Even so, the proposal is still warranted. Operators of EV chargers
10 should not be forced to replace their existing chargers simply because they could not get access to chargers made
11 by a given manufacturer. It is generally agreed that when section 3.40 was adopted, the equipment to satisfy it did
12 not exist for DC chargers. Reaching that point has required research and development by meter manufacturers and
13 charger manufacturers. The goal of regulation should be to handle the technology transition in a reasonable, fair
14 manner, without prejudice to operators that have made diligent efforts in procurement and operation of their chargers.

15 This proposal arrives without the formal approval of the U.S. National Work Group subgroup on EV charging. But
16 a similar proposal did have general consensus at the Work Group. NIST personnel solicited views on the proposal
17 through an email ballot at the end of June 2022. The resulting votes were 11 in favor, and 1 opposed. As of this
18 filing, NIST has not provided information on whether this vote was sufficient for the subgroup to formally endorse
19 the proposal. The one person voting “no” said that the person would have voted yes if the proposal included a 10-
20 year end date for the 5% tolerance. The current proposal has that feature and thus addresses the only concern
21 expressed by the sole “no” vote.

22 **Comments in Favor:**

23 **Regulatory:**

- 24 •

25 **Industry:**

- 26 •

27 **Advisory:**

- 28 •

29 **Comments Against:**

30 **Regulatory:**

- 31 •

32 **Industry:**

- 33 •

34 **Advisory:**

- 35 •

36 **Neutral Comments:**

37 **Regulatory:**

- 38 •

39 **Industry:**

- 40 •

1 **Advisory:**
 2 •

3 **Item Development:**
 4 New

5 Additional letters, presentation and data may have been submitted for consideration with this item. Please refer to
 6 www.ncwm.com/publication-15 to review these documents.

EVF-23.6
<p>Regional recommendation to NCWM on item status:</p> <p><input checked="" type="checkbox"/> Recommend as a Voting Item on the NCWM agenda <input type="checkbox"/> Recommend as an Information Item on the NCWM agenda <input type="checkbox"/> Recommend as an Assigned Item on the NCWM agenda <i>(To be developed by an NCWM Task Group or Subcommittee)</i> <input type="checkbox"/> Recommend as a Developing Item on the NCWM agenda <i>(To be developed by source of the proposal)</i> <input type="checkbox"/> Recommend Withdrawal of the Item from the NCWM agenda <i>(In the case of new proposals, do not forward this item to NCWM)</i> <input type="checkbox"/> No recommendation from the region to NCWM <i>(If this is a new proposal, it will not be forwarded to the national committee by this region)</i></p>
<p>Comments and justification for the regional recommendation to NCWM: <i>(This will appear in NCWM reports)</i></p> <p>The following comments were received during the 2022 SWMA Annual Meeting:</p> <p>Mr. Prince, State of Florida, spoke in favor of this item being a satisfactory compromise.</p> <p>Mr. Floyd, State of Louisiana, stated that he would rather not have devices with warning labels for accuracy.</p> <p>Ms. Goudy of Electrify America, the submitter of this item, recommended this move forward as a voting item.</p> <p>Mr. Stokes, State of South Carolina, stated that he supported the use of warning labels for these devices, and supported this item.</p> <p>The SWMA S&T Committee recommends this item move forward as a Voting Item.</p>

7

8 **EVF-23.7 ~~N.1. No Load Test, N.2. Startin Load Test., N.5.2. Accuracy Testing, And~~**
 9 **Appendix D: maximum deliverable amperes.**

10 **Source:**
 11 Electrify America

12 **Purpose:**
 13 The proposal would have the testing conducted at the contemplated 10%. Because it is unlikely that tests would
 14 actually be at precisely 10%, the proposal would allow testing in a small range slightly above 10%.

15 **Item under Consideration:**
 16 Amend Handbook 44 Electric Vehicle Fueling Systems Code as follows:

17 ~~N.1. No Load Test. A no load test may be conducted on an EVSE measuring system by applying rated voltage~~
 18 ~~to the system under test and no load applied.~~

1 ~~N.2. Starting Load Test. — A system starting load test may be conducted by applying rated voltage and 0.5-~~
2 ~~ampere load.~~

3 ...

4 **N.5.2.1. Accuracy Testing.** – The testing methodology compares the total energy delivered in a
5 transaction and the total cost charged as displayed/reported by the EVSE with that measured by the
6 measurement standard.

7 (a) For AC systems:

8 (1) Accuracy test of the EVSE system at a load of not less than 85 % of the maximum deliverable
9 amperes ~~(expressed as MDA) as determined from the pilot signal~~ for a total energy
10 delivered of at least twice the minimum measured quantity (MMQ). If the MDA would result
11 in maximum deliverable power of greater than 7.2 kW, then the test may be performed at 7.2
12 kW.

13 (2) Accuracy test of the EVSE system at a load of ~~not greater than~~ between 10 % and 20% of
14 the maximum deliverable amperes ~~(expressed as MDA) as determined from the pilot signal~~
15 for a total energy delivered of at least the minimum measured quantity (MMQ).

16 (b) For DC systems (see note):

17 (1) Accuracy test of the EVSE system at a load of not less than 85 % of the maximum deliverable
18 amperes ~~current (expressed as MDA) as determined from the digital communication~~
19 ~~message from the DC EVSE to the test standard~~ for a total energy delivered of at least twice
20 the minimum measured quantity (MMQ).

21 (2) Accuracy test of the EVSE system at a load of ~~not more than~~ between 10 % and 20% of the
22 maximum deliverable amperes ~~(expressed as MDA) as determined from the digital~~
23 ~~communication message from the DC EVSE to the test standard~~ for a total energy
24 delivered of at least the minimum measured quantity (MMQ).

25 **Note:** For DC systems it is anticipated that an electric vehicle may be used as the test load. Under that
26 circumstance, testing at the load presented by the vehicle shall be sufficient provided that it is greater than
27 30% of the maximum deliverable amperes of the EVSE system.

28 And

29 Appendix D:

30
31 maximum deliverable amperes. - The value in amperes, marked on an EVSE pursuant to paragraph S.5.2.
32 EVSE Identification and Marking Requirements, of the maximum current that the EVSE can provide.

33 **Previous Action:**

34 New item in 2023

35 **Original Justification:**

36 The accuracy tests in section 3.40 contemplate testing an EV charger at two points, one at relatively low current and
37 power, and the other at relatively high current and power. The low point was evidently intended to be at 10% of a
38 charger's maximum current. It is likely that charger manufacturers have designed chargers with that 10% in mind
39 as the "low" point of accuracy tests. But the code does not actually state that testing should be *at* 10%. It says testing
40 can be at a current *less than* 10%. This formulation is problematic because it encompasses any current less than
41 10%. Zero is less than 10%, and 0.1 A is less than 10% even though it is less than the amount at which the code
42 requires a charger to first register a load. Even currents larger than these, but less than 10%, would be unnecessarily

1 difficult for an accuracy test. The problem is that low currents are an area where accuracy is particularly difficult.
2 For example, one common metering configuration is to measure the current being delivered by means of a shunt
3 resistor, which generates a voltage from the high current passing through it. These resistors necessarily have very
4 low resistances because they are necessarily dissipating power in accordance with the resistance. A typical resistor
5 in an EV charger metering setup might be 100 micro-ohms. For a 500 amps full-scale current in a DC charger, that
6 resistor would be dissipating 25 watts of power - thus, a much larger resistor is not a practical option. At, say, 10
7 amps of delivered current, the voltage generated across the resistor would be 1 millivolt. A 1% measurement of that
8 1 millivolt would be 10 microvolts. At that level, a range of noise sources become quite significant, such as
9 thermal EMF in the resistor itself and induced EMFs from the presence within the charger cabinet of voltages up to
10 480 volts ac or 950 volts dc, as well as any offsets or noise in the circuitry measuring the transduced voltage. The
11 net result is that it is very challenging to achieve high accuracy at low currents in a device designed to handle and
12 measure high currents. For reasons like these, the draft international (OIML) standard specifies that an accuracy test
13 should be conducted *at* a given minimum current, rather than (like current Handbook 44) at any current *up to* that
14 minimum.

15
16 Meanwhile, low currents are the levels least significant for transactional accuracy. At low current, a charger is
17 delivering energy at a relatively low rate. As a practical matter, an EV will charge at the maximum rate possible in
18 the circumstances. As the battery reaches a higher state of charge, it will draw less power from the EV, but only a
19 small proportion of the overall energy will be delivered at low rates, precisely because the rates are low. Suppose
20 as a simplified example, an EV charges for 30 minutes at 300 amps and 30 minutes at 15 amps (at a voltage of 400
21 volts). The EV will have received 60 kWh in the first part of the session, and only 3 kWh in the second part. The
22 low-current period of charging contributes relatively little to the accuracy/inaccuracy of the overall transaction.

23
24 Thus, it is important for Handbook 44 to set a minimum current for accuracy tests. Because the point of 10% of
25 the maximum deliverable amperes is already in the code and has probably been used as a design basis for chargers,
26 the proposal would keep that as the low-current point. The overall concept would be for testing to occur *at* 10% of
27 maximum deliverable amperes, rather than *up to* 10%. But it is impractical to specify a single point. An inspection
28 that does not achieve a test at precisely the 10% should not, as a consequence, be an invalid inspection. To make
29 this practical, the proposal would have the low-end test occur in a range of currents, namely 10% to 20% of the
30 charger's maximum.

31
32 The code presents a similar problem for DC chargers tested using EVs as loads. The code allows an EV to be used
33 as the load, rather than using a controlled load that draws the loads specified in the code. But the code provides no
34 specifications about how to use an EV in this sort of test. So it is possible that a tester could use an EV that is, say,
35 at 95% state of charge in the battery, and that would arrive at the charger and draw very low levels of current
36 (sometimes called a "trickle charge"). For the reasons discussed above, that sort of test would not be a productive
37 test of the meaningful accuracy of the charger. The code should set a minimum current for an EV-based test to be
38 usable. The proposal would have that minimum be 30% of the charger's maximum. It is set at more than 10% because
39 the EV-based test uses a single test point, which should therefore be somewhere in the middle of the charger's range.

40
41 The proposal would also add a definition of "maximum deliverable amperes." This quantity is the same as
42 used in the existing code as the basis for the 10% figure, but it is not currently defined. The definition would state
43 that maximum deliverable amperes means the amount marked on the charger. (The code already requires that amount
44 to be marked.) This amount might be less than the manufacturer's specification for the potential maximum of the
45 device, if for example the installation limits the charger to a particular amount, or the installer has selected a
46 configuration with a lower maximum. But the maximum deliverable amount is a quantity that is fixed at installation
47 and marked on the charger. The current code suggests that maximum deliverable amperes is the amount that the
48 charger communicates to a vehicle or test apparatus. That approach is confusingly ambiguous, because the charger
49 might for various reasons sometimes communicate a lower available current than its marked maximum. The proposal
50 clarifies that for accuracy tests based on a percentage of maximum current, the "maximum" being used is the
51 maximum marked on the device.

1 These concepts have been discussed in the U.S. National Work Group’s subgroup on EV charging. There is general
2 consensus in favor of the proposal, but there has not been a quorum to vote formally in favor of it.

3

4 Finally, the proposal would eliminate the no-load and starting-load tests. These tests take unnecessary time, because
5 an inspector has to wait to verify that a load of zero genuinely produces no response and a starting load of
6 just 0.5 amps produces a response. Meanwhile, these tests are not meaningful for the transactional accuracy of an EV
7 charger. In the process of establishing a handshake that the EV charger is connected to a vehicle, the charger might
8 provide minute test amounts of current, so that a truly zero load is not pertinent to any real transaction; and these
9 minute test currents may well be above 0.5 amps, so that this threshold is also not pertinent to transactions. It would
10 be possible to verify that a charger does not register an energy delivery when no transaction is started, but that test
11 would be redundant of verifying that the charger starts at zero. Meanwhile, 0.001 kWh (the minimum resolution under
12 Handbook 44) corresponds to roughly 3 to 5 hundredths of a cent, so that verifying the registration of such tiny
13 amounts given a tiny current is not helpful for the overall transactional accuracy.

14 The submitter is not aware of objections that would be raised to this proposal. The concept is consistent with the
15 discussions at the U.S. National Work Group based on information from testing over the past six years, and input from
16 regulators and industry.

17 The submitter requested that this be a Voting item in 2023

18 **Comments in Favor:**

19 **Regulatory:**

- 20 •

21 **Industry:**

- 22 •

23 **Advisory:**

- 24 •

25 **Comments Against:**

26 **Regulatory:**

- 27 •

28 **Industry:**

- 29 •

30 **Advisory:**

- 31 •

32 **Neutral Comments:**

33 **Regulatory:**

- 34 •

35 **Industry:**

- 36 •

37 **Advisory:**

- 38 •

39 **Item Development:**

- 1 New
- 2 Additional letters, presentation and data may have been submitted for consideration with this item. Please refer to
- 3 www.ncwm.com/publication-15 to review these documents.

EVF-23.7
<p>Regional recommendation to NCWM on item status:</p> <ul style="list-style-type: none"> <input checked="" type="checkbox"/> Recommend as a Voting Item on the NCWM agenda <input type="checkbox"/> Recommend as an Information Item on the NCWM agenda <input type="checkbox"/> Recommend as an Assigned Item on the NCWM agenda <i>(To be developed by an NCWM Task Group or Subcommittee)</i> <input type="checkbox"/> Recommend as a Developing Item on the NCWM agenda <i>(To be developed by source of the proposal)</i> <input type="checkbox"/> Recommend Withdrawal of the Item from the NCWM agenda <i>(In the case of new proposals, do not forward this item to NCWM)</i> <input type="checkbox"/> No recommendation from the region to NCWM <i>(If this is a new proposal, it will not be forwarded to the national committee by this region)</i>
<p>Comments and justification for the regional recommendation to NCWM: <i>(This will appear in NCWM reports)</i></p> <p>The following comments were received during the 2022 SWMA Annual Meeting:</p> <p>Mr. Prince, State of Florida, supports this as a voting item.</p> <p>Ms. Goudy, Electrify America, recommends this item move forward as a voting item.</p> <p>The SWMA S&T Committee recommends this item move forward as a Voting Item.</p>

4

5 **GMA – GRAIN MOISTURE METERS 5.56 (A)**

6 **GMA-19.1 D Table T.2.1. Acceptance and Maintenance Tolerances Air Oven Method for**

7 **All Grains and Oil Seeds.**

8 **Source:**

9 NTEP Grain Analyzer Sector

10 **Purpose:**

11 Reduce the tolerances for the air oven reference method.

12 **Item Under Consideration:**

13 Amend Handbook 44, Grain Moisture Meter Code 5.56 (a) as follows:

14 **T.2.1. Air Oven Reference Method.** – Maintenance and acceptance tolerances shall be as shown in

15 Table T.2.1. Acceptance and Maintenance Tolerances Air Oven Reference Method. Tolerances are expressed as

16 a fraction of the percent moisture content of the official grain sample, together with a minimum tolerance.

17 (Amended 2001)

<p>Table T.2.1.</p> <p>Acceptance and Maintenance Tolerances Air Oven Reference Method</p>
--

Type of Grain, Class, or Seed	Tolerance	Minimum Tolerance
Corn, oats, rice, sorghum, sunflower	0.05 of the percent moisture content	0.8 % in moisture content
All other cereal grains and oil seeds	0.04 of the percent moisture content	0.7 % in moisture content

<u>Table T.2.1.</u> <u>Acceptance and Maintenance Tolerances Air Oven Reference Method</u> <u>for All Grains and Oil Seeds</u>	
<u>Tolerance</u>	<u>Minimum Tolerance</u>
<u>0.03 of the percent moisture content</u>	<u>0.5 % in moisture content</u>

(Amended 2001 **and 20XX**)

1 **Background/Discussion:**

2 This item has been assigned to the submitter for further development. For more information or to provide comment,
3 please contact:

4 Mr. Karl Cunningham
5 Illinois Department of Agriculture
6 217-785-8301, karl.cunningham@illinois.gov

7 Samples and list of grains that AMS, FGIS request from states to include in their ongoing calibration program. States
8 and other interested parties wanted to verify that corn samples from their state were included in the calibration data
9 for NTEP meters because of variations states reported between UGMA meter and other meter technologies on corn
10 samples.

11 During the 2016 Grain Analyzer Sector Meeting, numerous instances of inconsistent moisture meter measurements
12 involving grain shipments from U.S. interior facilities to U.S. export port facilities were reported. The Sector received
13 a suggestion that if the UGMA can make better measurements, then the Sector should consider reducing the applicable
14 tolerances in HB 44. At the 2016 and 2017 Grain Analyzer Sector meetings Mr. Charlie Hurburgh (Iowa State
15 University) agreed to chair a GA Sector Task Group to review the current HB 44 tolerance with both UGMA meters
16 and Non-UGMA meters. During the 2018 meeting Mr. Hurburgh reported that based on data he analyzed from Iowa
17 State Weights and Measures Grain Inspection reports, UGMA meters read closer to the reference air oven moisture
18 results than non-UGMA meters.

19 It was also noted during the 2018 NTEP Grain Analyzer Sector meeting that the current tolerances were developed in
20 1991 and have not been changed to coincide with the change in technology for these devices; and this action is needed
21 for grain industry risk management.

22 Prior to the 2019 NCWM Interim Meeting, all four regional weights and measures associations agreed to forward the
23 proposal as a voting item on the Interim Agenda. However, following the regional meetings, additional data was
24 submitted to the Sector which indicates a need to consider developing different tolerance for some grain types.
25 Through a subsequent ballot, and a majority vote, the Sector agreed to recommend changing the status of the item to
26 developing to provide the Sector time to consider additional data and changes to its original proposal.

27 NCWM 2019 Interim Meeting: The NCWM S&T Committee heard comments to agenda item GMA-3. Mr. Loren
28 Minnich (KS) commented that he spoke with Ms. Diane Lee (NIST OWM) and she reported that one state was

1 concerned with the application of the reduced tolerances to all grain types, specifically grains with hulls or husks. Mr.
 2 Minnich suggested that this item be assigned a “Developing” status to allow for more research into this issue. The
 3 committee also received written comments from NIST, OWM (see NIST, OWM Analysis posted on the NCWM
 4 Website). During the 2019 Interim Meeting, the S&T Committee considered the comments during the opening
 5 hearing and comments submitted prior to the meeting and assigned a “Developing” status for this item.

6 NCWM 2019 Annual Meeting: Ms. Diane Lee (NIST OWM) provided an update on the history of the item. Ms. Lee
 7 noted that the NTEP Grain Analyzer Sector will review data from Arkansas at its 2019 meeting intended to assure that
 8 proposed changes to the tolerances can be applied to all grains. Ms. Lee speaking on behalf of the Sector stated that
 9 the Developing status assigned to this item is appropriate.

10 NCWM 2020 Interim Meeting: The Committee heard from Ms. Diane Lee (NIST OWM) who stated that when this
 11 item was initially submitted the GMM Sector agreed to reduce tolerance based on data that was limited to corn and
 12 soybeans. Following the review of the initial data, additional data from Long Grain Rough Rice was reviewed and
 13 the sector agreed that additional data was needed on other grains to include oats, rice, and barley, prior to changing
 14 the tolerances. Ms. Lee requested that the item remain developing status as additional data is collected.

15 During the Committee’s work session, the committee agreed to retain this item as Developing to allow the submitter
 16 to continue working with members of the grain analyzer sector to collect additional data.

17 NCWM 2020 Annual Meeting: Due to the 2020 Covid-19 pandemic, this meeting was adjourned to January 2021, at
 18 which time it was held as a virtual meeting. Due to constraint of time, only those items designated as 2020 Voting
 19 Items were addressed. All other items were addressed in the subsequent 2021 NCWM Interim Meeting.

20 NCWM 2021 Annual Meeting: The Committee heard comments from Ms. Diane Lee (NIST OWM) who noted that
 21 additional data is needed to assess the proposed tolerances. Ms. Lee requested that this item remain Developing.
 22 During the Committee’s work session, the Committee agreed to a Developing status for this item.

23 NCWM 2022 Interim Meeting: The Committee heard comments from Ms. Diane Lee (NIST OWM) who noted that
 24 additional data is needed to assess the proposed tolerances. Ms. Lee added that states would be submitting more data.
 25 Ms. Lee requested that this item remain Developing. During the Committee’s work session, the Committee agreed to
 26 a Developing status for this item.

27 NCWM 2022 Annual Meeting: The Committee heard updates from Ms. Tina Butcher, NIST OWM. The original
 28 intent of this item was to apply the proposed tolerance to corn and soybeans, whoever, other grains were identified for
 29 areas of study. The Grain Sector was working with States to collect additional data; however, the pandemic has slowed
 30 the process. The Grain Sector is requesting additional time to collect this data. The Committee has agreed to maintain
 31 a Developing status for this item.

32 **Regional Associations’ Comments:**

33 WWMA 2021 Annual Meeting: Diane Lee (NIST OWM): This item has been on the agenda since 2019 - when it was
 34 proposed there was a study done on only corn and soybean samples (maybe we could lower the tolerances) subsequent
 35 to that, they received a report from a state to hold off to look at more data from different grain types (rough rice).
 36 Agreed to collect additional data, from a few additional states. A memo has gone out to participating states to collect
 37 more data on additional grains. They are in the process of collecting and hope to have a report in the interim on
 38 validity. Support as a developing item.

39 The WWMA S&T Committee recommends the status remain developmental.

40 SWMA 2021 Annual Meeting: The committee heard no comments on this item. This committee recommends this
 41 item remain Developing so that more data can be collected and presented in the future.

1 CWMA 2022 Annual Meeting: Doug Musick – KS - Some feel that rice won't be able to meet the tighter tolerance.
2 Supports moving to voting. No data has been submitted regarding the concern, so they can do this at a later date if
3 desired.

4
5 The CWMA S&T Committee recommends this moves forward as a voting item.

6 NEWMA 2022 Annual Meeting: Ms. Tina Butcher (NIST OWM) commented on background for this item. There
7 had been concerns if the current tolerances were too broad. The grain sector was looking into expanding the data set
8 to include additional grains but there has been significant delay due to pandemic.

9
10 After hearing comments from the floor, the committee recognized the need to further develop this item and
11 recommended the item retain developing status.

12 Additional letters, presentation and data may have been submitted for consideration with this item. Please refer to
13 www.ncwm.com/publication-15 to review these documents.

GMA-19.1	
Regional recommendation to NCWM on item status:	
<input type="checkbox"/>	Recommend as a Voting Item on the NCWM agenda
<input type="checkbox"/>	Recommend as an Information Item on the NCWM agenda
<input type="checkbox"/>	Recommend as an Assigned Item on the NCWM agenda <i>(To be developed by an NCWM Task Group or Subcommittee)</i>
<input checked="" type="checkbox"/>	Recommend as a Developing Item on the NCWM agenda <i>(To be developed by source of the proposal)</i>
<input type="checkbox"/>	Recommend Withdrawal of the Item from the NCWM agenda <i>(In the case of new proposals, do not forward this item to NCWM)</i>
<input type="checkbox"/>	No recommendation from the region to NCWM <i>(If this is a new proposal, it will not be forwarded to the national committee by this region)</i>
Comments and justification for the regional recommendation to NCWM: (This will appear in NCWM reports)	
No comments were received on this item during the 2022 SWMA Annual Meeting.	
The SWMA S&T Committee recommends this item remain as a Developing Item.	

14

15 **GMA-23.1** **N.1.3. Meter to Like-Meter Method Transfer Standards and Table T.2.2.**
16 **Acceptance and Maintenance Tolerances Meter to Like-Meter Method**

17 **Source:**
18 NTEP Grain Analyzer Sector

19 **Purpose:**
20 Clarify what is meant by the term Meter to Like Type Meter in the Grain Moisture Meter Code 5.56(a).

21 **Item under Consideration:**
22 Amend NIST Handbook 44 Grain Moisture Meters Code as follows:

23 **N.1.3. Meter to Like-Type Meter Method Transfer Standards.** – Properly standardized reference meters
24 using National Type Evaluation Program approved calibrations shall be used as transfer standards. A
25 reference meter shall be of the same type model family, as defined by the National Type Evaluation
26 Program Certificate of Conformance, as the meter under test. Tests shall be conducted side-by-side using,
27 as a comparison medium, grain samples that are clean and naturally moist, but not tempered (i.e., water
28 not added).

1 (Added 2001) (Amended 20XX)
 2 And
 3 T.2.2. Meter to Like-Type Meter Method. – Maintenance and acceptance tolerances shall be as shown
 4 in Table T.2.2. Acceptance and Maintenance Tolerances Meter to Like-Type Meter Method. The tolerances shall
 5 apply to all types of grain and seed.
 6 (Added 2001)

Table T.2.2. Acceptance and Maintenance Tolerances Meter to Like-Type Meter Method	
Sample Reference Moisture	Tolerance
Up to 22 %	0.5 % in moisture content

(Added 2001)

7
 8 **Note: See definition for like-type meter in N.1.3.**
 9 (Added 20XX)

10 **Previous Action:**
 11 New Item in 2023

12 **Original Justification:**

13 During the 2017 Grain Analyzer Sector meeting there was a discussion on Meter to like-type meter testing and the
 14 definition of a liker-type meter. There was discussion on test procedures for meter to like-type meter testing. It was
 15 noted that there may be only about two states using this type of test method and that it may be due to the cost of
 16 obtaining like-type meters to perform the test. A question was raised as to what is considered a like-type meter and it
 17 was explained that like-type meant that the make and model were the same. Suggestions were made to include a
 18 definition for like-type in NIST HB 44 and to consider documenting test procedures for meter to like-type meter
 19 testing.

20
 21 During the 2018 grain analyzer sector meeting, the sector discussed industry and State weights and measures programs
 22 that used meter to like-type meter testing and master meter test methods. Kansas reported that reference meters are
 23 used to collect moisture results on samples. The samples are then taken to the field to compare to commercial field
 24 moisture meters. It was also reported that most State weights and Measures that use a meter-to-meter test method for
 25 testing field meters do not use a meter to like-type meter testing program which is specified in NIST HB44. The Perten
 26 representative reported that Perten uses three layers of master meters when calibrating their devices. It was noted that
 27 an analysis of the failure rate for meter-to-meter test methods should be investigated and an analysis of all the issues
 28 for meter-to-meter test methods is needed along with test methods for this type of field testing.

29
 30 During the 2022 grain analyzer sector meeting the GA sector reviewed data from States and the NTEP laboratory and
 31 discussed what was considered like-type for this test method. Data collected in the NTEP program shows a bias
 32 between meters of different type, therefore adding an error to the test results when a meter of unlike type is used to
 33 test another meter. The GA sector agreed that like-type based on the current data available must be interpreted as the
 34 same model family, as defined by the National Type Evaluation Program Certificate of Conformance. As such the
 35 Sector agreed to add language to Section 5.56(a) paragraphs N.1.3 and T.2.2. to clarify the definition of like type.

36 The submitter acknowledged that some states may be using a meter-to-meter test method that is not a meter to like-
 37 type meter method.

38 The submitter requests Voting status.

1 **Comments in Favor:**

2 **Regulatory:**

- 3 •

4 **Industry:**

- 5 •

6 **Advisory:**

- 7 •

8 **Comments Against:**

9 **Regulatory:**

- 10 •

11 **Industry:**

- 12 •

13 **Advisory:**

- 14 •

15 **Neutral Comments:**

16 **Regulatory:**

- 17 •

18 **Industry:**

- 19 •

20 **Advisory:**

- 21 •

22 **Item Development:**

23 New

24 Additional letters, presentation and data may have been submitted for consideration with this item. Please refer to
25 www.ncwm.com/publication-15 to review these documents.

GMA-23.1	
Regional recommendation to NCWM on item status:	
<input checked="" type="checkbox"/> Recommend as a Voting Item on the NCWM agenda <input type="checkbox"/> Recommend as an Information Item on the NCWM agenda <input type="checkbox"/> Recommend as an Assigned Item on the NCWM agenda <i>(To be developed by an NCWM Task Group or Subcommittee)</i> <input type="checkbox"/> Recommend as a Developing Item on the NCWM agenda <i>(To be developed by source of the proposal)</i> <input type="checkbox"/> Recommend Withdrawal of the Item from the NCWM agenda <i>(In the case of new proposals, do not forward this item to NCWM)</i> <input type="checkbox"/> No recommendation from the region to NCWM <i>(If this is a new proposal, it will not be forwarded to the national committee by this region)</i>	
Comments and justification for the regional recommendation to NCWM: (This will appear in NCWM reports)	
No comments were received on this item during the 2022 SWMA Annual Meeting.	
The SWMA S&T Committee recommends this item move forward as a Voting Item.	

1

2 **MDM – MULTIPLE DIMENSION MEASURING DEVICES**

3 **MDM-22.1 D S.1.7. Minimum Measurement.**

4 **Source:**
 5 Parceltool P/L

6 **Purpose:**
 7 Exempt mobile tape based MDMD devices from the 12D minimum measurement.

8 **Item Under Consideration:**
 9 Amend Handbook 44, Multiple Dimension Measuring Devices Code as follows:

10 **S.1.7. Minimum Measurement.** – Except for entries of tare **and mobile tape based MDMD devices**, the
 11 minimum measurement by a device is 12 d. The manufacturer may specify a longer minimum measurement. For
 12 multi-interval devices, this applies only to the first measuring range (or segment) of each measurement axis
 13 (length, width, and height).
 14 (Amended 2017 **and 20XX**)

15 **Previous Action:**
 16 2022: Developing

17 **Original Justification:**
 18 The 12 d minimum measurement is designed for instruments that use an internal rounding function to round the actual
 19 measurement up or down to the nearest value of d before being displayed. For measurement of 12 d, or less, the
 20 potential error in the measurement is considered too large and therefore the specification of the 12 d minimum
 21 measurement is in place.

22 Measurements below 12 d are commonplace when using a mobile tape (tape measure) type of device for determining
 23 measurements. An accepted practice for this type of device is for the Measurement to be rounded up to the nearest
 24 whole unit of measurement (e.g., 1 inch) before being used to calculate any charges.

1 The submitter requested that this be a Voting Item in 2022.

2 **Comments in Favor:**

3 **Regulatory:**

- 4 •

5 **Industry:**

- 6 •

7 **Advisory:**

- 8 •

9 **Comments Against:**

10 **Regulatory:**

- 11 •

12 **Industry:**

- 13 • Russ Vires (SMA); SMA opposes the item.

14 **Advisory:**

- 15 •

16 **Neutral Comments:**

17 **Regulatory:**

- 18 • Matt Douglas (California Division of Measurement Standards) suggested that the submitter submit
19 data and work with the MDMD sector to develop the item.

20 **Industry:**

- 21 •

22 **Advisory:**

- 23 • Darrel Flocken (NCWM, NTEP); Explained the device they are seeking this change for is a tape
24 measure and they may have misunderstood what they are asking for.
25 • This was first proposed in 2019 and was withdrawn. There appears to be no new justification.

26 **Item Development:**

27 NCWM 2022 Interim Meeting: During the committee work session, the committee determined that more input was
28 needed from the submitter. This item has been assigned to the submitter for further development. For more
29 information or to provide comment, please contact:

30 Tony Bauer
31 Parceltool P/L
32 +61 439-89-2468, tbauer@cubical.com

33 2022 NCWM Annual Meeting: The committee heard no comments from the developer of the item.

34 **Regional Associations' Comments:**

35 WWMA 2021 Annual Meeting: Russell Vires (Mettler Toledo): Mettler is opposed to the change proposed here. No
36 reason to eliminate the minimum measurement.

1 The WWMA S&T Committee recommends that this item be assigned a Developmental status. The Committee
 2 recommends that the submitter provide data to support why the devices are unable to meet the 12-division requirement.
 3 The Committee also recommends that the submitter consult the MDMD working group.

4 SWMA 2021 Annual Meeting: Russ Vires, Mettler Toledo, requested that this item be withdrawn because the
 5 justification was invalid.

6 This committee recommends this item be Withdrawn due to having no justification provided for the change.

7 CWMA 2022 Annual Meeting: Russ Vires – SMA - The SMA opposes this item. The justification provided by the
 8 submitter does not adequately identify the issue this item is attempting to resolve, and why mobile tape-based MDMD
 9 devices should be exempted
 10 compared to all other MDMD devices. The SMA recommends that the submitter work with the MDMD Workgroup
 11 to develop a suitable solution to this issue.

12 The CWMA S&T Committee recommends this item to be withdrawn.
 13

14 NEWMA 2022 Annual Meeting: Mr. Russ Vires (SMA) rose to oppose the item. He commented that the justification
 15 provided by the submitter does not identify issue that is to be resolved. Mr. Vires suggested that the submitter work
 16 with MDM Workgroup for a solution and referenced the workgroup meets in May and will be discussing this proposal.

17
 18 After hearing comments from the floor, the committee recognized the need to further develop this item and
 19 recommended the item retain developing status.

20 Additional letters, presentation and data may have been submitted for consideration with this item. Please refer to
 21 www.ncwm.com/publication-15 to review these documents.

MDM-22.1
<p>Regional recommendation to NCWM on item status:</p> <p> <input type="checkbox"/> Recommend as a Voting Item on the NCWM agenda <input type="checkbox"/> Recommend as an Information Item on the NCWM agenda <input type="checkbox"/> Recommend as an Assigned Item on the NCWM agenda <i>(To be developed by an NCWM Task Group or Subcommittee)</i> <input type="checkbox"/> Recommend as a Developing Item on the NCWM agenda <i>(To be developed by source of the proposal)</i> <input checked="" type="checkbox"/> Recommend Withdrawal of the Item from the NCWM agenda <i>(In the case of new proposals, do not forward this item to NCWM)</i> <input type="checkbox"/> No recommendation from the region to NCWM <i>(If this is a new proposal, it will not be forwarded to the national committee by this region)</i> </p>
<p>Comments and justification for the regional recommendation to NCWM: <i>(This will appear in NCWM reports)</i></p> <p>The following comments were received during the 2022 SWMA Annual Meeting:</p> <p>Dr. Curran, State of Florida, stated that this item was not needed.</p> <p>The SWMA S&T Committee recommends this item be Withdrawn.</p>

22

23 **OTH – OTHER ITEMS**

24 **OTH-16.1 D Electric Watthour Meters Code under Development**

1 **Source:**

2 NIST, Office of Weights and Measures

3 **Purpose:**

- 4 1) Make the weights and measures community aware of work being done within the NIST U.S. National Work
5 Group (USNWG) on Electric Vehicle Fueling and Submetering to develop proposed requirements for electric
6 watt-hour meters used in submeter applications in residences and businesses;
- 7 2) Encourage participation in this work by interested regulatory officials, manufacturers, and users of electric
8 submeters.
- 9 3) Allow an opportunity for the USNWG to provide regular updates to the S&T Committee and the weights and
10 measures community on the progress of this work;
- 11 4) Allow the USNWG to vet specific proposals as input is needed.

12 **Item Under Consideration:**

13 This item was added to the NCWM S&T Committee's agenda as a "Developing Item" to allow a forum in which
14 progress of the USNWG can be reported as it develops legal metrology requirements for electric watt-hour meters and
15 continues work to develop test procedures and test equipment standards.

16 Ms. Tina Butcher (NIST OWM), Chair of the USNWG on Electric Refueling & Submetering has continued to provide
17 regular updates to the Committee on this work and to encourage input and participation from the weights and measures
18 community since the addition of this item to the Committee's agenda in 2016. See the Committee's 2016 through
19 2021 Final Reports for details.

20 The SG is nearing completion of a draft NIST Handbook code for "Non-Utility Electricity-Measuring Systems." Work
21 continues on a few sections of the draft code; however, the SG would like to begin getting feedback from the weights
22 and measures community on the draft code.

23 The draft code is available for download at <https://www.ncwm.com/publication-15>.

24 The Subgroup asks the NCWM S&T Committee to consider (and the regional associations to support) the following.

- 25 1. Permitting the item to remain in a Developing status on its agenda to allow for further development and input
26 on the draft Handbook 44 Code.
- 27
- 28 2. Permitting the SG to post the draft code along with other supporting documents on the NCWM S&T
29 Committee's web page. Areas under review and development by the SG will be noted in highlighted text.
- 30
- 31 3. Encouraging weights and measures officials and industry to study the draft code and provide input to the SG,
32 including proposed changes along with rationale for such changes and any indication of support or
33 opposition.

34 The SG requests comments be submitted to the SG Chair or Technical Advisor by the end of March 2022. The SG
35 will review and address comments, updating the draft code as needed and requesting the NCWM S&T Committee to
36 post updated versions for review as available. The SG will finalize a draft for submission in the 2022-2023 NCWM
37 cycle.

38 The above approach will allow the SG the opportunity to solicit input and incorporate comments from the weights and
39 measures community on the draft code in advance of proposing it for a vote more broadly.

40 The Electric Watt-hour Meter Subgroup (EWH SG) of the USNWG on Electric Vehicle Fueling & Submetering has
41 held multiple in-person and web meetings since the 2017 NCWM Annual Meeting. This SG has held 15 virtual
42 meetings since January 2021 focused on finalizing a draft code on "Non-Utility Electricity-Measuring Systems."

43 Those interested in participating in this work are asked to contact SG Chair, Ms. Lisa Warfield, or Technical Advisor,
44 Ms. Tina Butcher. Contact information is included in the "Background" section of this item.

1 **Background/Discussion:**

2 This item has been assigned to the submitter for further development. For more information or to provide comment,
3 please contact:

Electric Vehicle Refueling Subgroup:

Ms. Tina Butcher, Chair
NIST Office of Weights and Measures
301-975-2196, tbutcher@nist.gov
Or
Ms. Juana Williams, Technical Advisor
NIST Office of Weights and Measures
301-975-2196, juana.williams@nist.gov

Electric Watthour Meters Subgroup:

Ms. Lisa Warfield, Chair
NIST Office of Weights and Measures
301-975-3308, lisa.warfield@nist.gov
Or
Ms. Tina Butcher, Technical Advisor
NIST Office of Weights and Measures
301-975-2196, tbutcher@nist.gov

4 This item was submitted as a Developing item to provide a venue to allow the USNWG to update the weights and
5 measures community on continued work to develop test procedures and test equipment standards within its Electric
6 Vehicle Refueling Subgroup. This item will also serve as a forum in which to report work on the development of a
7 proposed tentative code for electric watthour meters in residential and business locations by the USNWG's Electric
8 Watthour Meters Subgroup and a placeholder for its eventual submission for consideration by NCWM.

9 Ms. Tina Butcher (NIST OWM), Chairman of the USNWG on Electric Refueling & Submetering has continued to
10 provide regular updates to the Committee on this work. See the Committee's 2016 through 2018 Final Reports for
11 details.

12 NCWM 2018 Interim Meeting: No comments were heard on this item and the Committee agreed to maintain its
13 "Developing" status. The Committee did not take comments during open hearings on Developing items at the 2018
14 NCWM Annual Meeting and agreed to allow only the submitter of a Developing item (or block of Developing items)
15 to provide an update on the progress made to further develop the item(s) since the 2018 NCWM Interim Meeting. The
16 Committee received an update on this item from Ms. Tina Butcher (NIST OWM), Chair of the USNWG on Electric
17 Refueling & Submetering. See the Committee's 2018 Final Report for Details.

18 OWM personnel were unable to attend the 2019 NCWM Interim Meeting due to the Federal Government shutdown
19 in early 2019 due to a lack of appropriations; however, OWM provided written comments to the Committee on this
20 item in the advance of the meeting, including the following update on this item:

- 21 • The Electric Watthour Meter Subgroup (EWH SG) of the USNWG on Electric Vehicle Fueling & Submetering
22 has held multiple in-person and web meetings since the 2017 NCWM Annual Meeting.
- 23 • The SG met in September 2017, November 2017, May 2018, and August 2018. All meetings included web-
24 conferencing to allow those not able to attend in person to participate.
- 25 • The SG developed a proposed addition to NIST Handbook 130's Uniform Regulation for the Method of Sale
26 (MOS) of Commodities (see Item MOS-8 on the L&R Committee's Agenda) to specify a method of sale for
27 electrical energy sold through these systems and submitted the proposal to the four regional weights and measures
28 association meetings in Fall 2018.
 - 29 ○ Three of the four regions recommend the MOS proposal on the L&R Agenda as a voting item, with the
30 fourth abstaining due to lack of experience with these systems within the region.
- 31 • The SG continues work on a proposed code for EWH-type meters for NIST Handbook 44 and expects to have a
32 draft ready for the 2020 NCWM cycle.
- 33 • OWM requests this item be maintained on the S&T Committee's agenda as a Developing Item while the SG
34 finalizes its proposed HB 44 draft. OWM will continue to apprise the Committee of progress.

SWMA S&T 2022 Annual Meeting Report

- 1 • At their Fall 2018 meetings, all four regional associations indicated support for maintaining this as a Developing
2 item on the Committee's agenda.
- 3 • The SG will hold its next in-person meeting in February 2019 in Sacramento, CA. (*Technical Advisor's Note:*
4 *This meeting was rescheduled to April 2019.*)
- 5 • Those interested in participating in this work are asked to contact SG Chair, Ms. Lisa Warfield, or Technical
6 Advisor, Ms. Tina Butcher.

7 NCWM 2019 Interim Meeting: The Committee heard no comments on this item. At its work session, Committee
8 members agreed with the submitter and the Regional Associations that this item should be assigned a Developing
9 status.

10 NCWM 2019 Annual Meeting: Ms. Tina Butcher (NIST OWM) provided the Committee with an update on the further
11 development of this item. Ms. Butcher reported that the EWH SG will meet next in August 2019 to continue its work
12 and requested this item remain on the S&T Committee agenda as a Developing item. During the committee's work
13 session, the Committee agreed with the submitter to retain this item in a Developing status.

14 NCWM 2020 Interim Meeting: The Committee heard from Ms. Butcher who provided an update on developments in
15 the Electric Watthour Meters Code which is also included in the NIST OWM analysis. Ms. Butcher requested that
16 this item be given a developing status.

17 During the Committee work session, the committee agreed that this item should be given a Developing status.

18 NCWM 2020 Annual Meeting: Due to the 2020 Covid-19 pandemic, this meeting was adjourned to January 2021, at
19 which time it was held as a virtual meeting. Due to constraint of time, only those items designated as 2020 Voting
20 Items were addressed. All other items were addressed in the subsequent 2021 NCWM Interim Meeting.

21 NCWM 2021 Interim Meeting: The Committee heard from Ms. Tina Butcher who provided an update on the
22 developments in the Electric Watthour Code which is include in the NIST OWM analysis and Ms. Butcher requested
23 that this item be given a developing status. The Committee agreed that the item be given a Developing status.

24 NCWM 2021 Annual Meeting: Ms. Tina Butcher (NIST OWM) provided an update on the developments in the
25 Electric Watthour Code which is included in the NIST OWM analysis. Ms. Butcher noted that the Electric Watthour
26 Code is in Development and anticipates a Code by Fall 2021. There was discussion on definitions for electric master
27 meters and possibly separating the definitions for gas and water master meters and Ms. Butcher requested that this
28 item be given a developing status. The Committee agreed that the item be given a Developing status.

29 NCWM 2022 Interim Meeting: Matt Douglas (California – DMS) stated that California supports the development of
30 this item but has concerns about identity marking requirements being on a separate document. Also that the devices
31 should be easy to test before and after instillation. This device should allow for electronic data logger. Juana Williams
32 (NIST) commented that the subgroup had provided a draft code that is on the website. Ms. Williams requested
33 comments be submitted to Tina Butcher (NIST) or Lisa Warfield (NIST) by March 22, 2022. Ms. Williams stated
34 these comments will be used to provide and updated draft for the 2022-2023 submission cycle and the item remain in
35 developing status. The Committee agreed that the item be given a Developing status.

36 As discussed at the weighing sector meeting, multiple vehicle types are tested during the NTEP publication 14 test. If
37 a specific vehicle type is failed or not tested, there needs to be a restriction on the vehicle types passed on the certificate.
38 This restriction must also be marked on the device.

39 **Regional Associations' Comments:**

40 WWMA 2021 Annual Meeting: Matt Douglas (California - DMS): California supports further development of this
41 item. Concerns about the identity marking information which allows a separate document to satisfy model and seral
42 number prefixes and doesn't clarify what constitutes a separate document other than hard or electronic and does not
43 originate from the system. We strongly feel that testing capabilities should be easily and readily achievable before and
44 after the installation as well as means for verifying validity of complaints based on inaccuracy. An observation – as

1 written the method of sealing category II and III requires a hard copy of audit trail and event logger information. Other
 2 codes are being considered to allow electronic forms of this information.

3 The WWMA S&T Committee recommends this item remain in a Developing status. The Committee acknowledged
 4 that, as referenced in the Committee’s agenda, the submitter of the item has asked the item to remain in a Developing
 5 status to allow for further refinement and input on the draft NIST HB 44 code. Based upon this information and the
 6 comments received during its open hearings, the Committee encourages the NIST USNWG Subgroup to consider the
 7 comments provided by CA DMS at the WWMA meeting. The Committee also encourages others in the weights and
 8 measures community to continue studying the draft code and provide input to the Subgroup as requested in the agenda
 9 item.

10 SWMA 2021 Annual Meeting: The committee heard no comments on this item. This committee recommends this
 11 item remain Developing so that more work can continue at the request of the submitter.

12 CWMA 2022 Annual Meeting: Lisa Warfield – NIST – An extensive group of industry and regulators are working
 13 to understand each other’s roles as this code develops. The NIST work group is quite active and making progress.

14
 15 The CWMA S&T Committee recommends this item to remain as developing.

16 NEWMA 2022 Annual Meeting: Ms. Tina Butcher (NIST OWM) commented that this item pertains to electric
 17 submeters. The workgroup is still working on the proposal and has prepared a draft, however, 3-4 items need to be
 18 resolved with criteria for marking and testing.

19
 20 After hearing comments from the floor, the committee recognized the need to further develop this item and
 21 recommended the item retain developing status.

22 Additional letters, presentation and data may have been submitted for consideration with this item. Please refer to
 23 www.ncwm.com/publication-15 to review these documents.

OTH-16.1
<p>Regional recommendation to NCWM on item status:</p> <ul style="list-style-type: none"> <input type="checkbox"/> Recommend as a Voting Item on the NCWM agenda <input type="checkbox"/> Recommend as an Information Item on the NCWM agenda <input type="checkbox"/> Recommend as an Assigned Item on the NCWM agenda <i>(To be developed by an NCWM Task Group or Subcommittee)</i> <input checked="" type="checkbox"/> Recommend as a Developing Item on the NCWM agenda <i>(To be developed by source of the proposal)</i> <input type="checkbox"/> Recommend Withdrawal of the Item from the NCWM agenda <i>(In the case of new proposals, do not forward this item to NCWM)</i> <input type="checkbox"/> No recommendation from the region to NCWM <i>(If this is a new proposal, it will not be forwarded to the national committee by this region)</i>
<p>Comments and justification for the regional recommendation to NCWM: <i>(This will appear in NCWM reports)</i></p> <p>The following comments were received during the 2022 SWMA Annual Meeting:</p> <p>Ms. Lisa Warfield, NIST, stated the workgroup planned to have an item in Pub 15 before the 2023 NCWM Interim Meeting.</p> <p>The SWMA S&T Committee recommends this item remain as a Developing Item.</p>

1 **BLOCK 1 ITEMS (B1) MINIMUM DRAFT SIZE WHEN USING A FIELD**
2 **STANDARD METER**

3 **Source:**
4 Endress+Hauser Flow USA, Inc.

5 **Purpose:**
6 Define the minimum test draft size when using a field standard meter.

7 **B1: LMD-23.1 N.3.5. Wholesale Devices**

8 **Item Under Consideration:**
9 Amend Handbook 44, Liquid Measuring Devices Code as follows:

10 **N.3.5 Wholesale Devices**

11 **N.3.5.1 Wholesale Devices** – The delivered quantity should be equal to at least the amount delivered by the
12 device in one minute at its maximum discharge rate and shall in no case be less than 200 L (50 gal).

13 **N.3.5.2. Field Standard Meter Test. – The minimum quantity for any test draft shall be equal to or**
14 **greater than the amount delivered in one minute at the flow rate being tested.**
15 **(Added 20XX, Nonretroactive as of January 1, 20XX)**

16 **B1: VTM-23.1 N.3. Test Drafts**

17 **Item Under Consideration:**
18 Amend Handbook 44, Vehicle Tank Meters Code as follows:

19 **N.3. Test Drafts**

20 **N.3.1. Test Drafts** - The delivered quantity should be equal to at least the amount delivered by the device
21 in 1 minute at its maximum discharge rate and shall in no case be less than 180 L (50 gal) or 225 kg (500
22 lb).

23 **N.3.2. Field Standard Meter Test. – The minimum quantity for any test draft shall be equal to or greater**
24 **than the amount delivered in one minute at the flow rate being tested. (Added 20XX)**
25 **(Added 20XX, Nonretroactive as of January 1, 20XX)**

26 **B1: MLK-23.1 N.3. Test Drafts**

27 **Item Under Consideration:**
28 Amend Handbook 44, Milk Meters Code as follows:

29 **N.3. Test Drafts**

30 **N.3.1. Test Drafts** - The delivered quantity should be equal to at least the amount delivered by the device in
31 one minute at its maximum discharge rate, and shall in no case be less than 400 L or 400 kg (100 gal or 1
32 000 lb).

33 **N.3.2. Field Standard Meter Test. – The minimum quantity for any test draft shall be equal to or greater**
34 **than the amount delivered in one minute at the flow rate being tested. (Added 20XX)**
35 **(Added 20XX, Nonretroactive as of January 1, 20XX)**

1 **Previous Action:**

2 2023: New Items

3

4 **Original Justification:**

5 **The proposal describes the minimum quantity test draft size, using a field standard meter, when testing a**
 6 **Liquid-Measuring Device.**

7 This proposal to amend the 3.30 Liquid-Measuring Devices Code, 3.31 Vehicle Tank Meters Code, 3.35 Milk Meters
 8 Code, and provides a clear recommendation for the test draft size using a field standard meter which is significantly
 9 less than the draft size needed for fixed volume provers. The use of field standard meters offers accurate traceable
 10 commissioning and enforcement testing of metering systems in a fraction of the time needed when using fixed volume
 11 proving standards or scales.

12 **Test drafts recommendations using field standard meters (master meters) are presently described in code**
 13 **sections 3.34. Cryogenic Liquid-Measuring Devices, 3.38 Carbon Dioxide Liquid-Measuring Devices, and 3.39.**
 14 **Hydrogen Gas-Measuring Devices.**

15 There are similar proposals to amend Mass Flow Meter and Liquefied Petroleum Gas codes to include field standard
 16 meters and describe the necessary test draft size.

17 **The devices used as field standard meters are calibrated to traceable national standards and the process and**
 18 **equipment used for the calibration has been audited by nationally accredited organizations. Documentation**
 19 **supporting the calibration and validation is supplied with the devices.**

20 The American Petroleum Institute and the American Gas Association have standard documents describing the use of
 21 master meters.

22 **State Directors have stated that the addition of language for field standard meters (master meters) is useful for**
 23 **them to support adoption in their jurisdictions.**

24 There has been opposition to the proposed Mass Flow Meter and Liquid Petroleum Gas codes Test Draft amendments
 25 for field standard meters. Those cite that Appendix A gives the Director authority to choose testing standards. They
 26 have initiated several proposals to amend language in Appendix A. There is a proposal to add language to the General
 27 Code. They have remained silent regard to the description of test drafts and master meters in the other sections of
 28 Handbook 44 and the confusing references in Appendix D definitions.

29 NIST has not written a 105 Series standard for field standard meters (master meters). In 2018, NIST began conducting
 30 a long-term test program of master meters

31 **Requested Status by Submitter:** Voting Item

32 **Comments in Favor:**

33 **Regulatory:**

- 34 •

35 **Industry:**

- 36 •

37 **Advisory:**

- 38 •

1 **Comments Against:**

2 **Regulatory:**

- 3 •

4 **Industry:**

- 5 •

6 **Advisory:**

- 7 •

8 **Neutral Comments:**

9 **Regulatory:**

- 10 •

11 **Industry:**

- 12 •

13 **Advisory:**

- 14 •

15 **Item Development:**

16 New

17 Additional letters, presentation and data may have been submitted for consideration with this item. Please refer to
18 www.newm.com/publication-15 to review these documents.

ITEM BLOCK 1

Regional recommendation to NCWM on item status:

- Recommend as a Voting Item on the NCWM agenda
- Recommend as an Information Item on the NCWM agenda
- Recommend as an Assigned Item on the NCWM agenda
(To be developed by an NCWM Task Group or Subcommittee)
- Recommend as a Developing Item on the NCWM agenda
(To be developed by source of the proposal)
- Recommend Withdrawal of the Item from the NCWM agenda
(In the case of new proposals, do not forward this item to NCWM)
- No recommendation from the region to NCWM
(If this is a new proposal, it will not be forwarded to the national committee by this region)

Comments and justification for the regional recommendation to NCWM: *(This will appear in NCWM reports)*

The following comments were received during the 2022 SWMA Annual Meeting:

Mr. Keilty, Endress+Hauser, stated that this block contained the same changes as LPG 15.1, which has already been approved. He also stated that electronic devices have changed a lot since 1989, and they still comply with the Fundamental Considerations.

Mr. Searles, American Petroleum Institute, stated that he supported this item moving forward as developing, and that devices should not be pointed out separately.

Mr. Murnane, Seraphin, stated that he supported this moving forward as a developing item.

Mr. Nicholas Suemnick, Marathon Petroleum, stated that he supported this moving forward as developing.

Mr. Prince, Stated of Florida, stated that the membership needs to make a decision on how we want to handle this issue.

The SWMA S&T Committee recommends this item move forward as a Voting Item.

1

2 **BLOCK 2 ITEMS (B2) DEFINE TRUE VALUE FOR USE IN ERROR**
3 **CALCULATIONS**

4 *NOTES:*

- 5 *1. At the 2020 NCWM Interim Meeting the committee agreed that GEN-20.1, SCL-20.1 and SCL-20.2 should*
- 6 *be removed from Block 2 and given individual consideration. The items included in this block 2 are SCL-*
- 7 *20.3, SCL-20.4, SCL-20.5, SCL-20.6, SCL-20.7 and SCL-20.8.*
- 8 *2. While this item was carried over from the 2020 Interim Meeting, it was not a voting item and therefore not*
- 9 *discussed during the continuation of the 2020 Annual Meeting. Instead, it was placed on the 2021 Interim*
- 10 *Meeting’s agenda and was discussed during that meeting.*

11 **Source:**

12 Ross Andersen (Retired)

13 **Purpose:**

14 This proposal has four parts:

- 15 1. Clarify the concepts in determining error in verification,
- 16 2. Correct Code references to ensure correct reference to either e or d, as appropriate,
- 17 3. Correct Code references regarding issues of scale suitability Table 8, and

1 4. Explain why e and d are not connected

2 **B2: SCL-20.3 A S.5.4. Relationship of Minimum Load Cell Verification Interval to the Scale**
 3 **Division**

4 **Item Under Consideration:**
 5 Amend Handbook 44, Scales Code as follows:

6 **S.5.4. Relationship of Minimum Load Cell Verification Interval Value to the Scale Division** – *The relationship*
 7 *of the value for the minimum load cell verification scale interval, v_{min} , to the verification scale division, d or e , for a*
 8 *specific scale using National Type Evaluation Program (NTEP) certified load cells shall comply with the*
 9 *following formulae where N is the number of load cells in a single independent¹ weighing/load-receiving element*
 10 *(such as hopper, railroad track, or vehicle scale weighing/load-receiving elements):*

11 (a) $v_{min} \leq \frac{d \text{ or } e}{\sqrt{N}}$ for scales without lever systems; and

12 (b) $v_{min} \leq \frac{d \text{ or } e}{\sqrt{N} \times (\text{scale multiple})}$ for scales with lever systems.

13
 14
 15 ¹“Independent” means with a weighing/load-receiving element not attached to adjacent elements and with its own
 16 A/D conversion circuitry and displayed weight.

17 [**When the value of the scale division, d , is different from the verification scale division, e , for the scale, the value*
 18 *of e must be used in the formulae above.**]
 19 *This requirement does not apply to complete weighing/load-receiving elements or scales, which satisfy all the*
 20 *following criteria:*

- 21 - *the complete weighing/load-receiving element or scale has been evaluated for compliance with*
 22 *T.N.8.1. Temperature under the NTEP;*
- 23 - *the complete weighing/load-receiving element or scale has received an NTEP Certificate of*
 24 *Conformance; and*
- 25 - *the complete weighing/load-receiving element or scale is equipped with an automatic zero-tracking*
 26 *mechanism which cannot be made inoperative in the normal weighing mode. (A test mode which*
 27 *permits the disabling of the automatic zero-tracking mechanism is permissible, provided the scale*
 28 *cannot function normally while in this mode.*

29 [*Nonretroactive as of January 1, 1994*]
 30 (Added 1993) (Amended 1996, ~~and~~ 2016, ~~and~~ **20XX**)

31 **B2: SCL-20.4 A Table 3. Parameters of Accuracy Classes.**

32 **Item Under Consideration:**
 33 Amend Handbook 44, Scales Code as follows:

Table 3.			
Parameters for Accuracy Classes			
Class	Value of the Verification Scale Division e^1 (d or e^1)	Number of Scale⁴ Divisions (n)	
		Minimum	Maximum

Table 3. Parameters for Accuracy Classes			
SI Units			
<i>I</i>	<i>equal to or greater than 1 mg</i>	<i>50 000</i>	<i>--</i>
<i>II</i>	<i>1 to 50 mg, inclusive</i>	<i>100</i>	<i>100 000</i>
	<i>equal to or greater than 100 mg</i>	<i>5 000</i>	<i>100 000</i>
<i>III</i> ^{2,5}	<i>0.1 to 2 g, inclusive</i>	<i>100</i>	<i>10 000</i>
	<i>equal to or greater than 5 g</i>	<i>500</i>	<i>10 000</i>
<i>III L</i> ³	<i>equal to or greater than 2 kg</i>	<i>2 000</i>	<i>10 000</i>
<i>IIII</i>	<i>equal to or greater than 5 g</i>	<i>100</i>	<i>1 200</i>
U.S. Customary Units			
<i>III</i> ⁵	<i>0.0002 lb to 0.005 lb, inclusive</i>	<i>100</i>	<i>10 000</i>
	<i>0.005 oz to 0.125 oz, inclusive</i>	<i>100</i>	<i>10 000</i>
	<i>equal to or greater than 0.01 lb</i>	<i>500</i>	<i>10 000</i>
	<i>equal to or greater than 0.25 oz</i>	<i>500</i>	<i>10 000</i>
<i>III L</i> ³	<i>equal to or greater than 5 lb</i>	<i>2 000</i>	<i>10 000</i>
<i>IIII</i>	<i>greater than 0.01 lb</i>	<i>100</i>	<i>1 200</i>
	<i>greater than 0.25 oz</i>	<i>100</i>	<i>1 200</i>

¹ **For Class I and II devices equipped with auxiliary reading means (i.e., a rider, a vernier, or a least significant decimal differentiated by size, shape, or color), the value of the verification scale division “e” is the value of the scale division immediately preceding the auxiliary means. The manufacturer may design a scale such that the verification scale division e does not be equal to the scale division d. To ensure the correct value for e is used, refer to marking requirements in footnotes 3 and 4 to Table S.6.3.a. and Table S.6.3.b. (Amended 20XX)**

² **A Class III scale marked “For prescription weighing only” may have a verification scale division (e) not less than 0.01 g. (Added 1986) (Amended 2003)**

³ **The value of the verification scale division (e) for crane and hopper (other than grain hopper) scales shall be not be less than 0.2 kg (0.5 lb). The minimum number of scale divisions shall not be less than 1000. (Amended 20XX)**

⁴ **On a multiple range or multi-interval scale, the number of divisions for each range independently shall not exceed the maximum specified for the accuracy class. The number of scale divisions, n, for each weighing range is determined by dividing the scale capacity for each range by the verification scale division, e, for each range. On a scale system with multiple load-receiving elements and multiple indications, each element considered shall not independently exceed the maximum specified for the accuracy class. If the system has a summing indicator, the *n_{max}* for the summed indication shall not exceed the maximum specified for the accuracy class. (Added 1997)**

⁵ **The minimum number of scale divisions for a Class III Hopper Scale used for weighing grain shall be 2000.)**

[Nonretroactive as of January 1, 1986]
(Amended 1986, 1987, 1997, 1998, 1999, 2003, ~~and~~ 2004, and 20XX)

1 **B2: SCL-20.5 A Table S.6.3.a. Marking Requirements, Note 3.**

2 **Item Under Consideration:**

3 Amend Handbook 44, Scales Code as follows:

- 4 3. The device shall be marked with the nominal capacity. *The nominal capacity shall be shown together with the*
 5 *value of the scale division “**d**” (e.g., 15 × 0.005 kg, 30 × 0.01 lb, or capacity = 15 kg, d = 0.005 kg) in a clear*
 6 *and conspicuous manner and be readily apparent when viewing the reading face of the scale indicator unless*
 7 *already apparent by the design of the device. Each scale division value ~~or weight unit~~ with its associated*
 8 ***nominal capacity** shall be marked on multiple range or multi-interval scales. In the absence of a separate*
 9 *marking of the verification scale division “e” (see Note 4), the value of the verification scale division e shall*
 10 *be equal to the value of the scale division d.*
 11 *[Nonretroactive as of January 1, 1983]*
 12 *(Amended 2005 and 20XX)*

13 **B2: SCL-20.6 A T.N.1.2. Accuracy Classes and T.N.1.3. Scale Division.**

14 **Item Under Consideration:**

15 Amend Handbook 44, Scales Code as follows:

16 T.N.1.2. Accuracy Classes. – Weighing devices are divided into accuracy classes according to the number of scale
 17 divisions (n) and the value of the verification scale division (~~d~~) (e).

18 T.N.1.3. Scale Division. – This Code contains references to two types of scale divisions, the verification scale
 19 division (e) and the scale division (d) (see definitions in Appendix D.). The tolerance for a weighing device is in
 20 the order of magnitude of related to the value of the scale division (d) or the value of the verification scale division
 21 (e) and is generally expressed in terms of ~~d~~ or e. Other technical requirements may reference either the
 22 verification scale division (e) or scale division (d) as appropriate. The values of (e) and (d) are chosen by the
 23 manufacturer and are marked on the device pursuant to S.6.3., except that d is not used in reference to an
 24 analog device, such as an equal-arm balance, where the graduations do not correspond to units of weight.

25 **B2: SCL-20.7 A Table 6. Maintenance Tolerances**

26 **Item Under Consideration:**

27 Amend Handbook 44, Scales Code as follows:

Table 6. Maintenance Tolerances (All values in this table are in <u>verification</u> scale divisions)						
Tolerance in <u>Verification</u> Scale Divisions						
	1	2		3		5
Class	Test Load					
I	0 - 50 000	50 001 -	200 000	200 001 +		
II	0 - 5 000	5 001 -	20 000	20 001 +		
III	0 - 500	501 -	2 000	2 001 -	4 000	4 001 +
IIIH	0 - 50	51 -	200	201 -	400	401 +
III L	0 - 500	501 -	1 000	(Add 1 d <u>e</u> for each additional 500 d <u>e</u> or fraction thereof)		

1 **B2: SCL-20.8 A Table 8. Recommended Minimum Load**

2 **Item Under Consideration:**

3 Amend Handbook 44, Scales Code as follows:

Table 8. Recommended Minimum Load		
Class	Value of Scale Division (d or e [±])*	Recommended Minimum Load (d or e [±])*
I	equal to or greater than 0.001 g	100
II	0.001 g to 0.05 g, inclusive	20
III	equal to or greater than 0.1 g	50
III L	All**	20
III	All	50
III	All	10

~~*For Class I and II devices equipped with auxiliary reading means (i.e., a rider, a vernier, or a least significant decimal differentiated by size, shape or color), the value of the verification scale division “e” is the value of the scale division immediately preceding the auxiliary means. For Class III and III devices the value of “e” is specified by the manufacturer as marked on the device; “e” must be less than or equal to “d.” Scales manufacturers are permitted to design scales where the value a verification scale division e differs from the displayed scale division d. If the marked value of e is less than the value of d, use e in interpreting the Table. In all other cases use the value of d. Refer to marking requirements for d and e in footnotes 3 and 4 to Table S.6.3.a. and Table S.6.3.b.~~
(Amended 20XX)

**A minimum load of 10 d e is recommended for a weight classifier marked in accordance with a statement identifying its use for special applications.

(Amended 1990) (Amended 20XX)

4
5 **Previous Action:**

6 2022: Assigned: Verification Scale Division (e) Task Group

7
8 **Background/Discussion:**

9 These items have been assigned to the newly formed Verification Scale Division (e) Task Group for further
10 development. For more information or to provide comment, please contact the task group chair:

11 Mr. Doug Musick
12 Kansas Department of Agriculture
13 785-564-6681, doug.musick@ks.gov

14 Most scales under the Scales Code are designated by the manufacturer to have a value of e that equals d. Where e and
15 d are not equal, there has been confusion in interpreting the Scales Code since the Code was adopted in 1984 (taking
16 effect in 1986). This confusion came to the forefront with the needs arising from the cannabis trade. I believe that
17 there were errors in translating OIML R76 (the basis of the current Scales Code) to HB44 format, there were key
18 issues that were lost in translation, and finally there is misunderstanding of the HB44 Code that contributed to this
19 confusion. This proposal will seek to identify the sources of confusion and offer revisions to make correction.

20 In this discussion I will be using the OIML term instrument when referencing a complete scale or weighing system.
21 This eliminated the dual meaning of the term “device.” A device will only refer to functioning parts of an instrument.

1 Finally, the term “scale” will not be a weighing instrument. Scale will refer only to the measurement scale, i.e., analog
2 graduations or digital divisions.

3 **1. Determining Error in Verification**

4 GEN-20.1.

5 In 2017, item 3200-7, a proposal to revise the expression of tolerances in several codes, was considered and withdrawn
6 by the S&T Committee. The proposal aimed to correct the missing reference in those codes to errors of over
7 registration and under registration. It also included a change to the definition of over registration and under registration
8 that was prompted in part to a lack of understanding of the process of verification. Many of the comments received
9 indicated that it was better handled through training. Additionally, the NCWM is working on the issue of alternative
10 test methods which directly impacts the subject of verification. In reviewing the 2017 proposal again, I believe the
11 real problem is a misunderstanding of the process of verification itself, stemming from a missing definition for “True
12 Value.”

13 The new definition and changes to the General Code correct deficiencies in the code. The “true value” has never been
14 clearly defined in code although it may be inferred from the definitions. The concept of true value is essential to
15 understanding verification process as it is used throughout the Handbook. It is also a legal issue establishing the basis
16 for tolerance decisions with the uncertain test procedure clearly stated. Our decisions are based on the true value
17 derived from a traceable standard and not based on the standard itself. Once established, the true value is considered
18 to have no error for purposes of legal verification. In our tests, the uncertainties in the test procedure are unquantified.
19 If you have to defend your test in court and are asked about the uncertainty in your test, what will you answer? With
20 the addition of the True Value definition, you have a traceable test report for your standard and the text of G-T.3.
21 regarding the legality of the specified test procedure. The verification process formally addresses the risks in two
22 ways. First the risks are kept small by the standard and procedure specified. Second, the risks are shared equally
23 between buyers and sellers. The enhancements explain clearly how errors are computed and how they are interpreted.

24 The addition of a % error definition in G-T.3. corrects a deficiency that was identified in testing LMD’s. The tolerances
25 in the LMD codes are expressed using errors of over registration /underregistration (device indication – true value).
26 Yet we in the US traditionally calculate those errors as errors of excess/deficiency (true value – device indication).
27 When calculating % error in these calculations, it seemed appropriate to put the device indication in the denominator,
28 but this is incorrect. All error calculations must be in terms of the true value, especially % calculations.

29 SCL-20.1

30 The addition of the Note addresses the issue of digital rounding. Parallel to R 76, the note requires errors to be
31 determined to a resolution of at least 0.2 e. Remember that error = indication – true value, and the true value is normally
32 the nominal value of the test weight. That means determining the indication to a resolution of 0.2 e or finer using error
33 weights or other means when $e \geq 2d$, or by directly reading the indications when $e \geq 5d$. This means if $e = 5d$ or e
34 $= 10d$, the indication is resolved fine enough to reduce the rounding error. In R76, the requirement is to “eliminate”
35 rounding error, but this is not possible. You can only reduce it to 0.5 of whatever division size you resolve the
36 indication. Hence, the proposal uses the term “reduce” instead of “eliminate.” The waiver allows field inspectors to
37 continue to use direct reading when $e = d$, with a resulting rounding error of 0.5 e. This accepts the additional risk of
38 passing devices outside the tolerances. (See section 4 of the proposal)

39 The changes to the two Scales Code tolerance paragraphs create a specific reference to the type of error in G-T.3. In
40 this case it formally states errors are errors of over registration/underregistration. The other change in T.1.1. addresses
41 the missing part about applying tolerances to net values as well as gross values for unmarked scales. I believe this was
42 just an oversight in 1984, as applying tolerances to either gross or net loads had been the established practice long
43 before the 1984 changes to the Scales Code.

44 **2. Correct Code references to ensure correct reference to either e or d, as appropriate.**

45 SCL-20.2

46 Section S.1.2.2. is not dealing with the verification scale division e as the title implies. Instead, it is dealing with
47 special requirements for instruments designed such that e does not equal d.

1 Section S.1.2.2.2. is not a specification issue directed to the manufacturer, but rather a question of suitability. It should
 2 have been put into the User Requirements section 1. Selection Requirements. For a discussion of the option to delete
 3 this refer to part 4 of the proposal.

4 SCL-20.3

5 The correct value for the table is e. The use of d in the formulas only works when $e = d$. That is addressed in the note
 6 * below, which is not necessary when e is used in the formulas.

7 SCL-20.4

8 • The inclusion of references to d in the header to column 2 of the table is technically incorrect. The verification
 9 scale division must refer only to e.

10 • The change to Note 1 serves to eliminate the confusion about considering e to be the digit to the left of d, and
 11 ensures the e value comes from the markings on the device. It is the manufacturer who chooses e for
 12 classification purposes.

13 • The changes to note 3 correctly references the verification scale division e and not the scale division d, and
 14 they clean up some grammatical errors.

15 SCL-20.5

16 The change clarifies that the verification scale division is equal to the marked d when no separate marking of e is
 17 provided. Note that nothing in Note 3 prevents marking $d = 1 \text{ g}$ $e = 1 \text{ g}$, or capacity $10000 \text{ g} \times 1 \text{ g}$ $e = 1 \text{ g}$. The change
 18 to the last sentence cleans up a nonsensical term “weight unit.” The scale division must be in a unit of weight, e.g., g,
 19 kg, lb, etc. The intent was to have each range of a multi-range device include a capacity and division size n. Note R76
 20 requires marking of Class, Max (capacity), and e, with a marking of d is only required when $e < d$.

21 SCL-20.6

22 The change to T.N.1.1.2. corrects the contradiction between the current code using d and the definition using e in
 23 determining accuracy class. The value of n in the definitions already correctly refers to e.

24 The change to T.N.1.1.3. is an attempt to clarify (e) and (d) similar to R 76 in Table 2. Note that when $e=d$, under
 25 S.6.3. only one marking is required. It is only when $e \neq d$ that S.6.3. requires both to be marked. The addition of
 26 material for ungraduated analog devices is housekeeping since d has no meaning for these devices. The change also
 27 clarifies that some requirements are directed to d (functional requirements on the device) and some to e (relating to
 28 classification and tolerance values).

29 **3. Discuss issues of suitability of scales when e and d are not equal.**

30 SCL-20.7

31 It is the value of e that is used in specifying tolerances according to the definition of e, and all values in this table must
 32 be expressed in terms of e. The table is currently written in terms of the scale division d, which is technically incorrect.

33 SCL-20.8

34 The parenthetical (d or e) in the headers to columns 2 and 3 is confusing when the two are not equal. Which one do
 35 you use? The note may address Class I and II devices, but it does not help with weight classifiers in Classes III and
 36 IIII, where you certainly don't want to use d.

37 It is vital to note that for instruments under R76 the manufacturer is required to mark a minimum load (Min). The
 38 manufacturer calculates Min using e. However, the minimum load is marked in mass units matching the instrument
 39 display in divisions of d. There is no confusion since it is marked on the instrument. In HB44 the inspector must
 40 determine the minimum load from Table 8 and the scale markings. Most users don't even know this requirement
 41 exists, unless told by the inspector.

1 Table 8 is addressing the large significance of rounding error at small loads. The
 2 table must be clear to ensure the correct scale division is used in enforcement. The
 3 table at right shows the relative errors resulting from roundoff to the nearest scale
 4 division d at various loads in the table. In principle, we are trying to ensure loads
 5 weighed are sufficient to reduce the relative errors to the levels shown, i.e. for
 6 Class I – 0.5%, for Class II – 1.0%, Class III – 1.0%, for Class III – 2.5%, and
 7 Class III – 5%. While these might seem large initially, there is a diminishing
 8 returns effect. A small percentage of a small number tends to be insignificant.
 9 Because the value of commodities goes up as the accuracy goes up, we have more stringent requirements on Classes
 10 I and II.

Load d	Relative Error
10	5.0%
20	2.5%
50	1.0%
100	0.5%

11 Scales fall into three categories, i.e. with $e > d$, $e = d$, and $e < d$.

- 12 • If $e < d$, e.g. weight classifiers, it seems clear the appropriate choice is e . The table in the second note specifies
 13 d , which is technically incorrect. For example, a Class III weight classifier with $d = 50$ g $e = 1$ g, the relative
 14 accuracy of 5% is reached at 10 e . At 10 d or (500 e) the relative error due to rounding is 0.1%.
- 15 • If $e = d$, it doesn't matter.
- 16 • If $e > d$, on some Class I and II scales, you get the desired relative error when you use d . If you use e , the
 17 scale with $e \neq d$ will result in much smaller rounding error since the rounding is internally applied to d and
 18 not to e . Examples: If $e = 0.1$ g, then 50 e is 5 g and the rounding error is $0.5 e / 50 e = 1\%$, i.e. the desired
 19 level for Class II. If $e = 0.1$ g and $d = 0.01$ g, then 50 e is 5 g and the rounding is to $0.5 d$ or $0.05 e$, thus the
 20 rounding error is $0.05 e / 50 e = 0.1\%$. This may be why the parenthetical (d or e) is used in the current
 21 language. Perhaps it was intended that we use the smaller value of the two if e and d are different. The
 22 proposal states e is used in cases where $e < d$ and d is used in all other cases. This eliminates any confusion.
 23 We may consider adding a marking of Min as per R76 as a future idea.

24 The change to the * note performs a similar function to the change in Note 1 in Table 3, as it disconnects e from
 25 d and relies solely on the markings of d and e .

26 In 2017, the NCWM added S.1.2.2.2. to prohibit use of Class I and II scales with a differentiated scale division. One
 27 argument was that the differentiated digit would cause confusion. There were arguments in opposition to the proposal.
 28 I argued that the confusion rested mostly with the weights and measures community (see earlier discussion). Plus, the
 29 finer digit extended the usable range of the scale since you could reach the 1% limit to rounding error at 50 d . For a
 30 Class II scale with $e = 0.1$ g and $d = 0.01$ g, that means weighing small loads down to 0.5 g loads which is something
 31 that users need in the cannabis trade.

32 One issue involves the rounding errors addressed in Table 8. A more critical issue
 33 in my view is the pricing increments. At
 34 \$30/g, 0.1 g e represents a pricing
 35 increment of \$3. By displaying 0.01 g d ,
 36 that 0.01 g d reduces the price increment to
 37 \$0.30. This is displayed in the graph at
 38 right. The blue line shows the 30 cent steps
 39 if you use the differentiated d . If you use
 40 the digit to the left of the differentiated d ,
 41 you see the counted divisions e discussed
 42 earlier. The gap between the blue and red
 43 lines shows the losses to users if they are
 44 forced to round down. The green line
 45 shows pricing on a normally rounded scale
 46 with 0.1 g e . The normal rounding shares
 47 the risk equally between buyer and seller.
 48

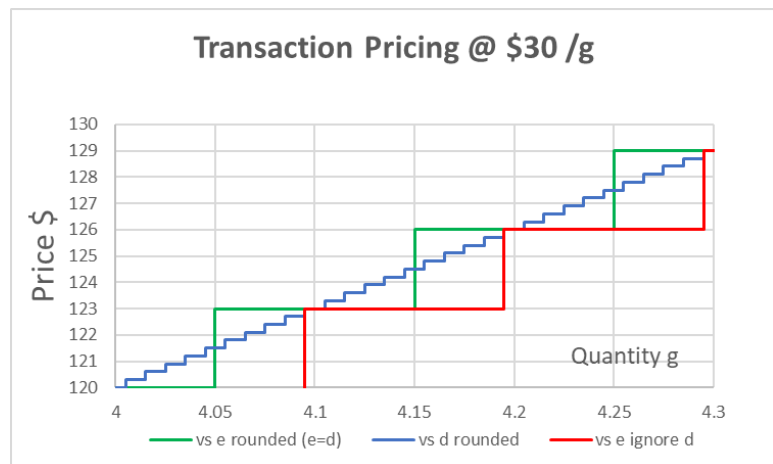

1 If the user must have a scale with $e = d$, then it forces them to go to 0.01 g e to service loads at the 1 g level. For that
 2 scale 50 e is 0.5 g, and the 1 g loads weighed are near 100 e. Precision scales rarely use 2 or 5 divisions, so capacities
 3 get reduced by a factor of 10 to move down to the next smaller division size. Blocking the use of $e=10d$ may force
 4 many users to purchase two scales where a single scale would have been suitable if using a scale with a differentiated
 5 d were not blocked.

6 **4. Discussion regarding disconnecting e from d**

7 Sections in the current Scales Code are being incorrectly interpreted to imply there is a direct connection between e
 8 and d. Essentially there is a belief when inspecting Class II scales when e does not equal d that we are somehow
 9 verifying the first digit to the left of d. Even when $e = d$, there is a belief that we are verifying d. That fails to follow
 10 the principles incorporated in G-T.3. We are not verifying the division; we are verifying the entire instrument
 11 indication at an applied load.

12 The scale division d is defined as the smallest division of the instrument under test (IUT). The scale division is referred
 13 to extensively in the code and we find that requirements written around d regulate the operating characteristics of the
 14 instrument, e.g. discrimination. When reading analog indications, we round to the nearest graduation (See Appendix
 15 A. Section 10). Under General Code G-S.5.2.2. (d), there is an important requirement that the smallest division of any
 16 digital device round off. Unless specifically designated the instruments in HB44 are in “normal rounding” class of
 17 instruments. Even with normal rounding, it is critical to understand that the digits to the left of the least significant
 18 digits are not rounded. They are counted. For example, as you count the rounded-off d’s, when you increment from 9
 19 to 0 in the least significant digit, the next digit increments 1 digit. The break point between digits to left of the least
 20 significant digit always occurs at 9.5 d. If d is 1 g, then the tenth d is counted as 10 g and the 100th d is counted as 100
 21 g, etc. Normal rounding of the tens place would normally occur at 5.0 d. If you attempt to apply tolerances to e and
 22 just ignore d, you are not rounding in conformance to G-S.5.2.2. (d). Instead, you are rounding down, which places
 23 the scale user at a disadvantage and disrupts equity.

24 UR.3.10. addresses dynamic monorail scales, which also have e
 25 \neq d, and requires that the commercial transaction using these
 26 devices shall be based on e, interpreted to mean the digit to the
 27 left of the differentiated d. These transactions therefore must be
 28 based on a counting scale (rounding down) instead of a half-
 29 up/half-down system as required in G-S.5.2.2. (d). When applied
 30 to a high-priced commodity at \$30 /g, the pricing errors add up
 31 because the scale user is forced to always round down. The table
 32 at right shows the impact, and this impact can be attributed to
 33 every transaction. At \$30/g, the average loss to the user per
 34 transaction is \$1.35. That is not equity!

Indication	\$ Using d	\$ Using e	\$ gain/loss
0.95	\$28.50	\$27.00	-\$1.50
0.96	\$28.80	\$27.00	-\$1.80
0.97	\$29.10	\$27.00	-\$2.10
0.98	\$29.40	\$27.00	-\$2.40
0.99	\$29.70	\$27.00	-\$2.70
1.00	\$30.00	\$30.00	\$0.00
1.01	\$30.30	\$30.00	-\$0.30
1.02	\$30.60	\$30.00	-\$0.60
1.03	\$30.90	\$30.00	-\$0.90
1.04	\$31.20	\$30.00	-\$1.20
1.05	\$31.50	\$30.00	-\$1.50

35 Verifying a scale division is virtually impossible. For a Class II
 36 device the accuracy requirement is approximately 0.01% of
 37 applied load. If the division is 0.1 g, then the required accuracy
 38 is ± 0.00001 g and we are trying to measure that with a resolution
 39 of 0.1 g. In addition, we don’t have standards below 1 mg.

40 I contend that e is not the digit to the left of the differentiated d! Nor do we verify e. Careful reading of the definition
 41 of the verification scale division “e” in Appendix D will reveal no direct connection between e and the indications on
 42 the instrument being verified. The verification scale division is a mass (weight) value declared by the manufacturer in
 43 required markings that is used in classifying instruments and in specifying tolerances for the device. In the header to
 44 column 2 in Table 3., we find the expression “Verification Scale Divisions (d or e¹). This is another chance to
 45 misunderstand the Code. The verification scale division must be e according to the definition. It can’t be d, although
 46 it can have the same value as d. Similarly, reading Note 1 in Table 3, you might conclude that e is the value of the
 47 digit immediately to the left of d. The critical distinction is that e is a value of that digit and not the actual division of
 48 the display. To avoid confusion, I propose amending Table 3. to simply direct you to the scale markings to find e and
 49 remove any reference to the digit in the display.

1 The e value is also used in classifying instruments in the Scales Code. Classes refer to relative error ranges. This comes
 2 from the ratio MTol / e. At the second step in the tolerance structure in Table 6. Under HB44 a Class III instrument is
 3 ~0.1% accurate. This is 2 e tolerance for a load of 2,000 e. A Class II instrument is accurate to ~0.01 %, or 2 e error
 4 for a load of 20,000 e. However, the tolerances within a class are stepped, such that the % error varies through the
 5 operating range. For Class II the relative errors are 0.02% at 5,000 e, 0.01% at 20,000 e and 0.0033% at 100,000 e.
 6 The manufacturer decides what class and relative accuracy he needs to serve (based on capacity and n) and designs
 7 accordingly.

8 If e is not a division on the instrument, what is it? In R76, the basis of our current Scales Code, the term “scale” is not
 9 used to refer to a weighing instrument, but rather the graduations or divisions, i.e., the “scale” of indication. Thus, a
 10 scale division is not limited to weighing devices. A register on an LMD has a “scale division,” e.g., a RMFD typically
 11 indicates in 0.001 gal divisions of scale. It should be easy to see the 0.001 gal increments correspond to d in the Scales
 12 Code. When we verify the RMFD, we use a test measure with an independent scale, either 1 in³ for older measures
 13 and 0.5 in³ for newer measures. The “verification scale” for the RMFD is therefore the “scale” on the test measure
 14 used to determine the true value. The instrument scale and the verification scale connect at only one point, at ZERO!
 15 Error arises when the two scale diverge as you move along the measurement scale due to linearity errors, influence
 16 factors, random variations, etc., within the instrument. The Verification Scale is considered to have no error.

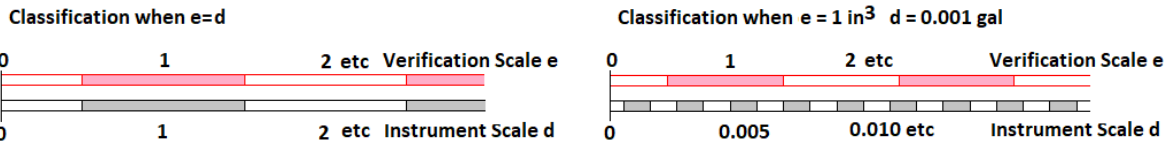

17
 18
 19 Above at left, the graphic shows a case where e = d. Notice how the divisions d and e both begin at center zero and
 20 the divisions align perfectly because at this magnification it is impossible to see small differences. The test evaluates
 21 the sum of many divisions in order to see any deviation. Above at right, the graphic shows how the 1 in³ e for the
 22 RMFD verification aligns with the 0.001 gal d of the instrument. Now imagine what happens when a test is performed.

23 Classification is based on relative error. This allows the verification scale division to differ from the instrument scale
 24 division, sometimes larger and sometimes smaller. With the RMFD above right, d is significantly smaller than e. In
 25 fact, the 6 e maintenance tolerance is 25 d. The two scales are independent. Would anyone suggest that the d smaller
 26 than e is inappropriate for commercial use. We verify the RMFD to e just like the weighing instrument with e = 10 d.
 27 The confusion comes from the requirement to differentiate d on these instruments.

28 Why does the Code require d to be differentiated when d is smaller than e? That is the critical question. It is not
 29 because d is somehow inaccurate or unreliable. It is not because d is smaller than the e of the tolerances. I believe it
 30 is because the code wanted to ensure that the serviceworker or official did not use d for tolerance calculations. It had
 31 nothing to do with users or customers.

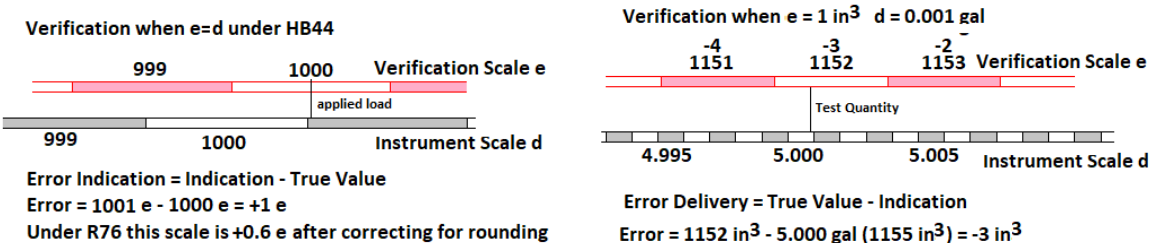

32
 33 In the above graphics, the instrument scale diverges from the verification scale. They both started at the same zero
 34 reference. Notice that the RMFD at right calculates delivery error vs indication error at left. The key is to understand
 35 that the verification scale has no error and we are measuring the deviation of the instrument scale from the verification
 36 scale.

1 This pattern holds true for other verification tests, from tests of packaged goods with a reference scale to tests of
 2 taximeters on a road course. Circling back to the proposed definition of true value, in addition to its use in classifying
 3 scales, **the verification scale is that “scale” used to measure the true value. The division of that “true value”**
 4 **measurement scale is “e.”** With the new G-T.3. that true value is the legal basis of our tests and is known without
 5 uncertainty. A table of a variety of verifications and their d and e scales are provided below.

Instrument & quantity	Instrument scale division d	Verification scale division e	Maintenance Tolerance	Ratio MT/e
RMFD @ 5 gal	0.001 gal	1 in ³ 0.5 in ³	6 in ³	6 12
VTM @ 100 gal	0.1 gal	5 in ³	~70 in ³	14
Rack @ 1,000gal	1 gal	0.1 gal	3 gal	30
Mass Flow Class 0.3	<= 0.2% MMQ	<= 0.02%	0.3%	15
Taximeter @ 1 mi	0.2 mi	~0.001 mi (!5 ft)	+0.01/-0.04 mi	10/40
Package Checking @ 1 lb	N/A	<= 0.005 lb	0.044 lb	8.8
@ 4 oz	N/A	<= 0.002 lb	0.016 lb	8
III scale e = d @ 200 d	1 d	1 e = 1 d	2 e	2
III scale e = d @ 2,000 d	1 d	1 e = 1 d	2 e	2
II scale e = d @ 20,000 d	1 d	1 e = 1 d	2 e	2
II scale e = 10 d @ 20,000 e	1 d	1 e = 10 d	2 e	2

6 The last column of the table is the real focus of verification. We want to have sufficient resolution in determining
 7 errors. Although the issue is a bit more complicated, this ratio is a measure of the effectiveness of the verification.
 8 Special notes:

- 9 • For the RMFD, VTM, and Rack instruments the ratio is limited by HB105-3 and the specified minimum
 10 division of the prover scale. This becomes part of the code when you specify the prover must meet that
 11 specification.
- 12 • For the mass flow instruments the Notes provide no guidance on the verification scale division. I submit the
 13 value of resolution in error should be in HB44 Notes for all Codes, similar to R76 for weighing instruments.
 14 This is something I hope the work group on alternative test methods addresses. The EPO does specify the
 15 reference scale division be no larger than 1/10 of the smallest tolerance applied. This means the Mass Flow
 16 code requires a minimum ratio of 15:1 for maintenance tolerance which I believe is overkill and very costly.
 17 Compare to 5:1 elsewhere.
- 18 • For scales the ratio is only 2:1 as currently written in Handbook 44. There is no mention of error weights in
 19 the Code. In R76, the ratio is specified in that it requires errors to be determined to at least 0.2 e. This produces
 20 a ratio of 5:1 in the first step, 10:1 in step two and 15:1 in step three. If you determine errors to 0.1 e, as we
 21 do normally with error weights, it allows you to double those ratios and provide 10:1 in the first step. Reading
 22 the errors in d when e = 5 d or e = 10d, allows you to meet the minimum without using error weights (or
 23 expanded resolution).

24 Why use maintenance tolerance in computing this ratio? In verification, there is a shift in emphasis relative to
 25 calibration. In verification, your primary concern is with the population. You want all the devices in the same
 26 commercial field to have performance that is similar enough to promote equity. Even if you are little sloppy in applying
 27 acceptance tolerance, the instrument is highly likely to perform within maintenance tolerances. In calibration, the
 28 focus is always on a single artifact or instrument.

1 Why is this resolution in determining errors important? The short answer is to
 2 reduce the incidence of false acceptance/rejection. The Range of False
 3 Acceptance (RFA) can be defined as the portion of the compliant measured
 4 error that reaches outside the tolerance limits due to rounding in the error
 5 calculation. Limiting the RFA is the objective in specifying the resolution of
 6 errors.

7 When we use direct reading in testing weighing instruments the ratio of Tol:e
 8 in the first tolerance step is 1:1 and we have an RFA of $\frac{1}{2} e$ in proportion to the
 9 1 e tolerance. The RFA is 50% of the tolerance, meaning we can accept
 10 instruments in error up to 1.5 times the tolerance. When we add the R76
 11 requirement to measure errors to 0.2 e we increase the ratio of Tol:e to 5:1 and
 12 thereby reduce the RFA to 0.1 e in proportion to the 1 e maintenance tolerance
 13 (see graphic at right). This RFA is only 10% of the tolerance. Statistically, it
 14 can be shown that the RFA contributes to the population variability based on
 15 the Root Sum Square. At $\frac{1}{2} e$ RFA when Tol:e is 1:1, the population variability
 16 gets increased by 22%. When we increase the Tol:e ratio to 5:1 the population variation is only increased by 1%,
 17 which is not considered significant.

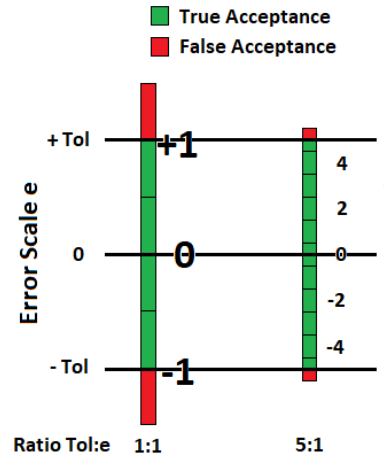

18 A better way to express this in is terms of compliance rate. Imagine your test data shows compliance of a class of
 19 devices as 95% at 1 e tolerance, but you are testing using direct reading. Due to rounding in measuring the error that
 20 you are not addressing, 95 % of the instruments are actually within 1.22 e and not the 1.00 e indicated in the compliance
 21 data. By increasing the Tol:e ratio to 5:1, 95% of the instruments are accurate within 1.01 e.

22 2020 NCWM Interim Meeting: The Committee acknowledged written comments from the submitter and heard
 23 comments during the open hearing session on this item. Mr. Constantine Cotsoradis (Flint Hills Resources) and Mr.
 24 Russ Vires (SMA) representing interests from an industry perspective questioned the need for the changes being
 25 proposed in this block of items. Additional comments from regulatory officials indicated that the changes included in
 26 this proposal were not successful in clarifying HB44 requirements and possibly added to any confusion that exists.
 27 Mr. Steve Cook (CA, retired) pointed out that the changes ignored weighing devices that did not fall under Accuracy
 28 Class I or II and stated his willingness to work with the submitter to further develop the proposal.

29 Several other comments heard during open hearings indicated that it is questionable to include all of the individual
 30 items that are shown as part of Block 2. Comments from SMA, and some regulatory officials recommended that this
 31 Block of items be separated since not all items now grouped under Block 2 seem to be closely related. Mr. Kurt Floren
 32 (Los Angeles Co., CA) also pointed out that some of the proposed amended language is not clear and will add to
 33 confusion in interpretation of requirements and that there are some editorial corrections and proper formatting needed
 34 in this proposal as well.

35 NIST OWM commented that while most of the proposed changes seem to be fundamentally sound, the urgent need
 36 to implement some of those proposed changes is not clear. OWM also agreed with other comments that recommend
 37 separating the items under Block 2 into individual items or grouped together where items are more clearly related.
 38 OWM notes that item SCL-20.2 now included in Block 2 is clearly related to two other items individually listed on
 39 the S&T Committee’s agenda: SCL-20.10 and SCL-20.11. Additionally, OWM believes that the determination if
 40 individual Scales Code requirements are meant to apply to either “e” or “d” should be carefully considered on a case-
 41 by-case basis. Also recommended was that additional input be solicited from stakeholders (industry officials and
 42 device manufacturers in particular) prior to adopting any changes based on this proposal.

43 During the Committee’s work session, they agreed that some of the items combined under Block 2 should be separated.
 44 The Committee agreed that items GEN-20.1, SCL-20.1, and SCL-20.2 should be removed from Block 2 and given
 45 individual consideration. Considering items individually, the Committee agreed to the following:

- 46 • Item GEN-20.1: The Committee acknowledged the receipt of comments from some of the regional
 47 associations concerning the use of the term “True Value” in the formulas included in parts (a) & (b) and how
 48 it is defined in the proposal. The Committee agreed that there may be value in further defining the application

1 of tolerance and that the item should be given a Developing status adding that consideration should be given
2 to amending the use of the term “True Value.”

- 3 • Item SCL-20.1: There were no direct comments regarding this item during open hearings. The Committee
4 reviewed NIST OWM’s analysis on this item and agreed it should be withdrawn noting this proposed change
5 is unnecessary.
- 6 • Item SCL-20.2: During open hearings this item was discussed relative to items SCL-20.10 and SCL-20.11
7 which address the same issue. Most comments received were in favor of option 2 in this proposal which was
8 effectively the same as SCL-20.10. The Committee agreed this item should also be withdrawn.
- 9 • Items SCL-20.3: The Committee agreed items SCL-20.4, SCL-20.5, SCL-20.6, SCL-20.7, and SCL-20.8
10 should be grouped together as Block 2 and given an Assigned status.

11 NCWM 2020 Annual Meeting: Due to the 2020 Covid-19 pandemic, this meeting was adjourned to January 2021, at
12 which time it was held as a virtual meeting. Due to constraint of time, only those items designated as 2020 Voting
13 Items were addressed. All other items were addressed in the subsequent 2021 NCWM Interim Meeting.

14 NCWM 2021 Interim Meeting: The Committee heard comments on this item during the open hearing session
15 including the following.

16 Mr. John Barton (NIST OWM) stated that as a member of the Task Group assigned to this item, that group met on
17 several occasions over the past 4 months to deliberate on the issues involved in this proposal. While the Task Group
18 came to conclusions that are included in the final report, there had been other individuals and groups that came to
19 different conclusions on those issues. Those other individuals and groups included subject matter experts, NTEP
20 evaluators, scale manufacturers, and the NTEP Weighing Sector. Mr. Barton further stated that given the impact of
21 changes proposed in this item, it may be wise to include additional sources of input prior to adopting the recommended
22 changes.

23 It was also noted that the Committee set a date of November 15, 2023 for the Task Group to return its conclusions and
24 that the Task Group finalized its work in a matter of 4 months rather than using the 3 years granted. It is also significant
25 to note that the Task Group requested an Informational status for this item as opposed to a Voting status. This suggests
26 that the Task Group is open to the notion that the proposal could be vetted further even when they have generated a
27 “final” report on their work.

28 Mr. Henry Opperman (Weights and Measures Consulting) referred to the written comments he submitted to the
29 Committee prior to this meeting and stated that all individual items in this Block should be withdrawn. Mr. Opperman
30 stated that the proposals in this Block are based on false premises and therefore should not be adopted. Mr. Alan
31 Walker (FL) agreed with Mr. Opperman and stated this proposal should be withdrawn also.

32 During the committee’s work session, the Committee considered updating the charge to the TG to direct that group to
33 specifically identify each change recommended in the final report to actual changes proposed as amendments in HB
34 44. The Committee also recommends this remains as an assigned item.

35 NCWM 2021 Annual Meeting: At the request of the Task Group Chair, the Committee elevated the status of this item
36 from Assigned to the task group to Informational.

37 NCWM 2022 Interim Meeting: Rick Harshman (NIST) recommended that the Task Group provide the committee
38 with its recommendations in the form of an updated item under consideration. NIST also provided the committee with
39 written comments. Doug Musik (Task Group Chair) spoke to the changes the task group had made that were in
40 Appendix A of the publication and recommended sending it back to the Task Group. Russ Vires (SMA) supports the
41 development of the item and recommended the following changes;

42 **SCL-20.4: Table 3, footnote 1: note to discuss e not equal to d**

1 **SCL-20.6: “d” in parathesis () should be struck out**

2 SCL-20.7: table 6 added SCL-20.8: scales may have verification internal e not equal to scale division “D”

3 Matt Douglas (California, Division of Measurement Standards) recommended accepting the changes from SMA.
4 Charlie Stutsman (KS) recommended sending the item back to the Task Group.

5 The Committee agreed the item should be assigned back to the Task Group and that the item be refined and submitted
6 to the conference.

7 NCWM 2022 Annual Meeting: During open hearings, the Committee received an update from the Task Group Chair
8 Doug Musick (KS). Mr. Musick indicated that the Task Group created a report in 2021 that had been added to
9 Publication 15 and 16 as an Appendix. This report contains an analysis of the items under consideration, as well as
10 recommendations for language changes to those items. Mr. Musick requested a joint meeting with the Task Group
11 and the S&T and L&R Committees for coordinating moving the recommended changes to the items under
12 consideration. The Committee recommends this remains Assigned and is requesting the Task Group facilitate joint
13 meeting and work on moving the recommended changes from the report into the items under consideration.

14 **Regional Associations’ Comments:**

15 WWMA 2021 Annual Meeting: Matt Douglas (California - DMS): the language is not clear, recommend that this
16 item be withdrawn. (the whole block). Russell Vires (Scale Manufactures Association): this is a carryover item. SMA
17 supports further development of this item, recommend that the SMA encourage the use of term: Verification Scale
18 Interval for (e) and Scale Division for (d). (he can send info.) States that his comments are the same from the Annual
19 meeting. Diane Lee (NIST OWM): NIST OWM comments on this item are posted on NCWM website

20
21 The WWMA S&T Committee recommends that this item remain informational with concern given to the comments
22 given during the WWMA open hearings. During the Committee work session, clarification was given regarding
23 Committee member Matt Douglas’ (California - DMS) testimony questioned whether or not the item provides
24 assistance to an Inspector in the field in the performance of their job.

25 SWMA 2021 Annual Meeting: Russ Vires, SMA, supports further development of this item, and recommended the
26 descriptive name changes for “e” and “d” as posted on the NCWM website.

27
28 This committee recommends this item move forward with an Assigned status.

29 CWMA 2022 Annual Meeting: Russ Vires – SMA - The SMA supports the further development of this item and the
30 work of the Verification Scale Division (e) Task Group. Recommendation: The SMA would also like to encourage
31 the use of the terminology “Verification Interval” for “e” and “Scale Division” for “d” in every instance that it appears
32 in this item.

33
34 Loren Minich – KS - Items shown under consideration are not the items the task group has submitted. The SMA
35 recommendations conflict with current task group verbiage.

36
37 Doug Musick – KS – This proposal got put into the ~~National~~ Committee Agenda Appendix for some reason. Hope to
38 rebuild the task group and get cleaned up before 2022 national. “verification interval” should be “verification scale
39 division” (e), and “displayed scale division” (d). Having (d) and (e) in the same original table was confusing to
40 inspectors. The current task group changes won’t be in Pub 16 for the 2022 National meeting.

41
42 Loren Minich – KS - Prefers the S&T committee to evaluate the Appendix since it’s more up to date.

43
44 The CWMA S&T Committee recommends this item remain as assigned.

45 NEWMA 2022 Annual Meeting: Mr. Russ Vires (SMA) commented on the block in general to support development
46 and encourage the use of “verification interval” for e and “scale division” for d in every instance as it appears in this
47 block. Ms. Tina Butcher (NIST OWM) believes latest revisions from task group have addressed concerns.

48

1 After hearing comments from the floor, the committee recognized the need to further develop this block and
 2 recommended the block retain assigned status.
 3 Additional letters, presentation and data may have been submitted for consideration with this item. Please refer to
 4 www.ncwm.com/publication-15 to review these documents.

ITEM BLOCK 2
<p>Regional recommendation to NCWM on item status:</p> <p><input type="checkbox"/> Recommend as a Voting Item on the NCWM agenda</p> <p><input type="checkbox"/> Recommend as an Information Item on the NCWM agenda</p> <p><input checked="" type="checkbox"/> Recommend as an Assigned Item on the NCWM agenda <i>(To be developed by an NCWM Task Group or Subcommittee)</i></p> <p><input type="checkbox"/> Recommend as a Developing Item on the NCWM agenda <i>(To be developed by source of the proposal)</i></p> <p><input type="checkbox"/> Recommend Withdrawal of the Item from the NCWM agenda <i>(In the case of new proposals, do not forward this item to NCWM)</i></p> <p><input type="checkbox"/> No recommendation from the region to NCWM <i>(If this is a new proposal, it will not be forwarded to the national committee by this region)</i></p>
<p>Comments and justification for the regional recommendation to NCWM: <i>(This will appear in NCWM reports)</i></p> <p>No comments were received on this item during the 2022 SWMA Annual Meeting.</p>
<p>The SWMA S&T Committee recommends this item remain as an Assigned Item.</p>

5

6 **BLOCK 3 ITEMS (B3) TOLERANCES FOR DISTANCE TESTING IN TAXIMETERS**
 7 **AND TRANSPORTATION NETWORK SYSTEMS**

8 **Source:**
 9 New York Department of Agriculture and Markets

10 **Purpose:**
 11 Provide the same distance-measurement tolerances for the Taximeters Code and Transportation Network Systems
 12 Code.

13 **B3: TXI-20.1 D T. Tolerances**

14 **Item Under Consideration:**
 15 Amend Handbook 44, Taximeters Code as follows:

16 **T. Tolerances**

17 **T.1. Tolerance Values.**

18 **T.1.1. On Distance Tests.** – Maintenance and acceptance tolerances for taximeters shall be as follows:

19 (a) On Over registration: 1 % of the interval under test **when the distance is 1.6 km (1 mile) or**
 20 **less. 2.5 % of the interval under test when the distance is greater than 1.6 km (1 mile).**

1 **B3: TNS-20.1 D T. Tolerances**

2 **Item Under Consideration:**

3 Amend Handbook 44, Transportation Network Systems Code as follows:

4 **T. Tolerances**

5 **T.1.1. Distance Tests.** – Maintenance and acceptance tolerances shall be as follows:

6 (a) On Over registration: ~~2.5%~~ **1 % of the interval under test when the distance is 1.6 km (1**
7 **mile) or less. 2.5 % of the interval under test when the distance is greater than 1.6 km (1 mile).**

8 (b) On Underregistration: ~~2.5 %~~ **4 % of the interval under test.**

9 **Previous Action:**

10 2020: Developing

11 2021: Developing

12 2022: Developing

13 **Comments in Favor:**

14 **Regulatory:**

- 15 • A regulator from New York presented current edits of the proposal at the time of his comments. These
16 edits were not published in Publication 15 and when presented during open hearings, membership was
17 unable to view the content due to the projected size on the screen and on online screens. The
18 commenter stated that many taxis operate with a GPS based systems and are still categorized as a taxi
19 meter due to the nature of their business and this would provide the same tolerances for similar
20 technology. Recommends revised version move forward as Voting status.

21 **Industry:**

- 22 • No Comments

23 **Advisory:**

- 24 • No Comments

25

26 **Comments Against:**

27

28 **Regulatory:**

- 29 • A regulator from Los Angeles County, CA commented this may set a dangerous precedence and noted
30 the same requirements should apply to similar devices, regardless of design or technology used.
31 Recommends withdraw.
- 32 • A regulator from California DMS commented there is no justification for increasing the tolerances for
33 equipment already meeting the requirements. Recommends withdraw.

34 **Industry:**

- 35 • No Comments

36 **Advisory:**

- 37 • An advisory member representing NIST OWM commented on the expansion of tolerances and noted
38 that taximeters have a long-standing history showing these devices can meet these established
39 tolerances. The commenter recommends the submitter work on the proposal and engage in efforts to
40 merge the taximeter and TNMS codes with the USNWG. It was also stated the USNWG has this item
41 on their agenda for further discussion. Recommends the proposal be further developed with the
42 assistance of the USNWG.

43 **Neutral Comments:**

44 **Regulatory:**

- No Comments

Industry:

- No Comments

Advisory:

- No Comments

Item Development:

Background/Discussion:

This item has been assigned to the submitter for further development. For more information or to provide comment, please contact:

Mr. Jim Willis
New York Department of Agriculture and Markets
518-485-8377, james.willis@agriculture.ny.gov

Taximeter manufacturers are submitting devices identical to the devices in the Transportation Network Measurement Systems code; however, they are faced with a tighter tolerance for over-registration. Both devices are typically computer pads or cell phones. Taximeter companies want to take advantage of some of the same technology used by TNMS companies, however, the tolerance for taximeters is much tighter than the tolerance for TNMS meters. During type evaluation, it is common to drive more than 1 mile to incorporate tunnels and valley effect. If the same tolerance was applied, taximeters would have the same chance of passing as TNMS meters.

Some jurisdictions that test taximeters may not want the tolerance for a 1-mile course to be raised given the good history of their test programs. This is the reason I am proposing maintaining the 1% tolerance at 1 mile or less.

Some TNMS companies may be concerned that their device will not pass a 1% tolerance, but we believe that on a straight, 1-mile course, devices operating properly should have no problem passing.

NCWM 2020 Interim Meeting: The Committee heard from NIST OWM explaining that the proposal is not technically correct by inserting language that refers to “intervals” in the tentative HB 44 TNMS Code. These types of systems do not calculate a charge for fare using intervals (i.e., segments) of the total travel in a trip as do taximeters. TNMS calculate fare charges based on the entire distance/time in a trip. Additionally, these two different systems (taximeters and TNMS) are becoming more similar and the differences that were used to distinguish them from one another are beginning to fade. OWM noted there is a need for the USNWG on Taximeters that developed the tentative TNMS Code to meet and discuss the potential of a merger of these two HB 44 Codes. Mr. Kurt Floren (Los Angeles Co., CA) pointed out that taximeters have been and still are meeting existing tolerances and therefore he questions the need to expand those tolerance values.

Mr. Stan Toy (Santa Clara Co., CA) expressed his belief that the tolerances for taximeters do not need to be expanded and that this item should be Withdrawn. Mr. Jim Willis (NY) pointed out that New York Weights and Measures has issued its own type approval for taximeters that use location services such as GPS to measure distance. Mr. Willis stated further that NY would support a Developing or Assigned status.

During the Committee’s work session, it was agreed to assign a Developing status with the understanding the USNWG on Taximeters has offered to assist the submitter in further development of the proposal.

NCWM 2020 Annual Meeting: Due to the 2020 Covid-19 pandemic, this meeting was adjourned to January 2021, at which time it was held as a virtual meeting. Due to constraint of time, only those items designated as 2020 Voting Items were addressed. All other items were addressed in the subsequent 2021 NCWM Interim Meeting.

NCWM 2021 Interim Meeting: Mr. John Barton (NIST OWM) stated that OWM noted issues of concern in this proposal during the 2020 NCWM Interim Meeting regarding how tolerances are applied to taximeters in contrast to how they are applied to TNMS. This proposal does not seem to recognize these differences. OWM also notes the many opposing

1 comments made pertaining to the increase of tolerances for taximeters which have complied with existing tolerances for
2 decades. The NIST USNWG on Taximeters has been conducting meetings with a goal of merging the HB 44 Taximeters
3 and TNMS Codes. This work will include a number of modifications to both codes that will affect the specifications, test
4 procedures, user requirements, and possibly the tolerances. The USNWG has offered to work with the submitter of this
5 proposal.

6 Mr. Willis representing the submitter of this item stated a willingness to work the USNWG on Taximeters.

7 During the committee's work session, the members noted the submitter's willingness to work with the taximeter work
8 group and agreed to maintain this item's Developing status.NCWM 2022 Interim Meeting: The Committee assigned
9 a developing status for this item at the 2022 Interim Meeting. The committee recommends the submitter work with
10 the USNWG on this proposal. As noted in open hearings this is an item on the USNWG agenda and there may be
11 efforts on the way to address this issue by other means.

12 NCWM 2022 Annual Meeting: During open hearings, the Committee received an update from submitter Jim Willis,
13 New York. Based on feedback, Mr. Willis has made language changes which will be updated for the fall meetings.
14 Mr. Willis requested that the item retain its developing status.

15 **Regional Associations' Comments:**

16 WWMA 2021 Annual Meeting: Kurt Floren (LA County): This coincides with previous comments: new tech with
17 GPS tracking and network companies are out. We are now taking age-old tech that's meeting 1% tolerance and
18 proposing to expand the tolerance. (existing equipment has been meeting with no issues). He does not support this
19 item until the data has been evaluated. He recommends this item to remain developmental until more data is available.

20 The WWMA S&T Committee recommends the status remain developmental.

21 SWMA 2021 Annual Meeting: The committee heard no comments on this item. This committee recommends this
22 item remain a Developing item so that the involved parties have more time to find a way to align the tolerances in the
23 Handbook.

24 CWMA 2021 Interim Meeting: Charlie Stutesman – KS – Interested to know why the tolerance isn't consistent with
25 underregistration and over registration.

26
27 The submitter of this item provided an updated proposal on March 23, 2022, which is posted on the NCWM website.
28 This update clarified the tolerances for TXI-20.1 and recommended withdrawal of TNS-20.1.

29
30 The CWMA S&T Committee recommends withdrawal of TNS-20.1 per the submitter's request. The Committee
31 recommends that TXI-20.1 proceed to voting status as presented in the March 23, 2022, updated proposal:

32 **T.1. Tolerance Values.**

33 **T.1.1. On Distance Tests.** – Maintenance and acceptance tolerances for taximeters shall be as follows:

34 **T.1.1.1 Meters Using Distance generated from sources physically connected to the vehicle (e.g. OBD** 35 **sensor).**

36 (a) On over registration: 1 % of the interval under test.

37 (b) On Underregistration: 4 % of the interval under test, with an added tolerance of 30 m or 100 ft
38 whenever the initial interval is included in the interval under test.

39 **T.1.1.2 Meters Using Distance generated from sources not physically connected to the vehicle (e.g** 40 **navigation satellite system such as GPS and /or other location services).**

41 (a) On over registration: 2.5 %

1 (b) On Underregistration: 2.5 %.

2 NEWMA 2022 Annual Meeting: Mr. Jim Willis (NY) has submitted some updated language and asks that this item
 3 continue to be developing.

4
 5 After hearing comments from the floor, the committee recognized the need to further develop this block and
 6 recommended the block retain developing status.

7 Additional letters, presentation and data may have been submitted for consideration with this item. Please refer to
 8 www.ncwm.com/publication-15 to review these documents.

ITEM BLOCK 3
<p>Regional recommendation to NCWM on item status:</p> <p> <input type="checkbox"/> Recommend as a Voting Item on the NCWM agenda <input type="checkbox"/> Recommend as an Information Item on the NCWM agenda <input type="checkbox"/> Recommend as an Assigned Item on the NCWM agenda <i>(To be developed by an NCWM Task Group or Subcommittee)</i> <input checked="" type="checkbox"/> Recommend as a Developing Item on the NCWM agenda <i>(To be developed by source of the proposal)</i> <input type="checkbox"/> Recommend Withdrawal of the Item from the NCWM agenda <i>(In the case of new proposals, do not forward this item to NCWM)</i> <input type="checkbox"/> No recommendation from the region to NCWM <i>(If this is a new proposal, it will not be forwarded to the national committee by this region)</i> </p>
<p>Comments and justification for the regional recommendation to NCWM: <i>(This will appear in NCWM reports)</i></p> <p>No comments were received on this item during the 2022 SWMA Annual Meeting.</p> <p>The SWMA S&T Committee recommends this item remain as a Developing Item.</p>

9

10 **BLOCK 4 ITEMS (B4) ELECTRONICALLY CAPTURED TICKETS OR RECEIPTS**

11 *NOTE: The item under consideration reflects changes that were received by the committee from the submitter of the*
 12 *item and that the Committee agreed to during its 2021 Interim Meeting work session. The changes are highlighted.*

13 **Source:**

14 Kansas Department of Agriculture, Division of Weights and Measures

15 **Purpose:**

16 Allow recorded values to be captured electronically as an alternative to a printed ticket or receipt.

17 **B4: GEN-21.2 D G-S.5.6. Recorded Representations.**

18 **Item Under Consideration:**

19 Amend Handbook 44, General Code as follows:

20 **G-S.5.6. Recorded Representations.** – Insofar as they are appropriate, the requirements for indicating and
 21 recording elements shall also apply to recorded representations. All recorded values shall be ~~printed provided~~
 22 **presented** digitally. In applications where recorded representations are required **by a specific code**, the customer
 23 may be given the option of not receiving the recorded representation. **Unless otherwise specified, recorded**
 24 **representations referenced in specific codes shall be made available to the customer as a minimum in hard**

1 **copy form. However,** for systems equipped with the capability of issuing an electronic receipt, ticket, or other
2 recorded representation, the customer may be given the option to receive any required information electronically
3 (e.g., via cell phone, computer, etc.) in lieu of or in addition to a hard copy.
4 (Amended 1975, 2014 and **20XX**)

5 **B4: LMD-21.2 D S.1.6.5. Money Value Computations., UR.3. Use of a Device.**

6 **Item Under Consideration:**

7 Amend Handbook 44, Liquid Measuring Devices Code as follows:

8 **S.1.6.5. Money-Value Computations**

9 ...

10 ***S.1.6.5.6. Display of Quantity and Total Price, Aviation Refueling Applications.***

11 (a) *The quantity shall be displayed throughout the transaction.*

12 (b) *The total price shall also be displayed under one of the following conditions:*

13 (1) *The total price can appear on the face of the dispenser or through a controller adjacent to the*
14 *device.*

15 (2) *If a device is designed to continuously compute and display the total price, then the total price*
16 *shall be computed and displayed throughout the transaction for the quantity delivered.*

17 (c) *The total price and quantity shall be displayed for at least five minutes or until the next transaction*
18 *is initiated by using controls on the device or other customer-activated controls.*

19 (d) *A **printed** receipt shall be available and shall include, at a minimum, the total price, quantity, and*
20 *unit price.*

21 *[Nonretroactive as of January 1, 2008]*

22 (Added 2007) (**Amended 20XX**)

23 **S.1.6.7. Recorded Representations.** – *Except for fleet sales and other price contract sales and for*
24 *transactions where a post-delivery discount is provided, a **printed** receipt providing the following information*
25 *shall be available through a built-in or separate recording element for all transactions conducted with point-of-*
26 *sale systems or devices activated by debit cards, credit cards, and/or cash:*

27 (a) *the total volume of the delivery;**

28 (b) *the unit price;**

29 (c) *the total computed price;**

30 (d) *the product identity by name, symbol, abbreviation, or code number;* and*

31 (e) *the dispenser designation by either an alphabetical or numerical description.***

32 **[Nonretroactive as of January 1, 1986] **[Nonretroactive as of January 1, 2021]*

33 (Added 1985) (Amended 1997, 2012, 2014, 2018 and **20XX**)

34 **S.1.6.8. Recorded Representations for Transactions Where a Post-Delivery Discount(s) is Provided.** –
35 Except for fleet sales and other price contract sales, a **printed** receipt providing the following information shall

1 be available through a built-in or separate recording element that is part of the system for transactions involving
2 a post-delivery discount:

- 3 (a) the product identity by name, symbol, abbreviation, or code number;
- 4 (b) transaction information as shown on the dispenser at the end of the delivery and prior to any post-delivery
5 discount(s), including the:
 - 6 (1) total volume of the delivery;
 - 7 (2) unit price; and
 - 8 (3) total computed price of the fuel sale.
- 9 (c) an itemization of the post-delivery discounts to the unit price;
- 10 (d) the final total price of the fuel sale after all post-delivery discounts are applied; and
- 11 (e) *the dispenser designation by either an alphabetical or numerical description.*

12 *[Nonretroactive as of January 1, 2021]*
13 (Added 2012) (Amended 2014, ~~and~~ 2018, and 20XX)

14 ...

15 **UR.3. Use of a Device**

16 ...

17 **UR.3.3. Computing Device** – Any computing device used in an application where a product or grade is
18 offered for sale at one or more unit prices shall be used only for sales for which the device computes and displays
19 the sales price for the selected transaction.

20 (Became retroactive 1999)

21 (Added 1989) (Amended 1992)

22 The following exceptions apply:

- 23 (a) Fleet sales and other price contract sales are exempt from this requirement.
- 24 (b) A truck stop dispenser used exclusively for refueling trucks is exempt from this requirement provided
25 that:
 - 26 (1) all purchases of fuel are accompanied by a ~~printed~~ receipt of the transaction containing the
27 applicable price per gallon, the total gallons delivered, and the total price of the sale; and
 - 28 (Added 1993)
 - 29 (2) unless a dispenser complies with S.1.6.4.1. Display of Unit Price, the price posted on the dispenser
30 and the price at which the dispenser is set to compute shall be the highest price for any transaction
31 which may be conducted.
 - 32 (Added 1993)
- 33 (c) A dispenser used in an application where a price per unit discount is offered following the delivery is
34 exempt from this requirement, provided the following conditions are satisfied:

1 (1) the unit price posted on the dispenser and the unit price at which the dispenser is set to compute
2 prior to the application of any discount shall be the highest unit price for any transaction;
3 (Amended 2014)

4 (2) all purchases of fuel are accompanied by a receipt recorded by the system. The receipt shall contain:

5 a. the product identity by name, symbol, abbreviation, or code number;

6 b. transaction information as shown on the dispenser at the end of the delivery and prior to any
7 post-delivery discount including the:

8 1. total volume of the delivery;

9 2. unit price; and

10 3. total computed price of the fuel sale prior to post-delivery discounts being applied.

11 c. an itemization of the post-delivery discounts to the unit price; and

12 d. the final total price of the fuel sale.

13 (Added 2012) (Amended 2014)

14 (Added 1989) (Amended 1992, 1993, 2012, ~~and 2014, and 20XX~~)

15 **UR.3.4. ~~Printed Ticket, Recorded Representation.~~** – The total price; the total volume of the delivery; the
16 price per liter or gallon; *and a corresponding alpha or numeric dispenser designation** shall be ~~shown, either~~
17 ~~printed recorded~~ by the device ~~or in clear hand script~~, on any ~~printed ticket issued by a device and recorded~~
18 ~~representation~~ containing any one of these values ~~and shall comply with G-S.5.6.~~ Establishments where no
19 product grades are repeated are exempt from the dispenser designation requirement.

20 **[Nonretroactive as of January 1, 2021]*

21 (Amended 2001, 2018, ~~and 2019, and 20XX~~)

22 **B4: VTM-21.1 D S.1.1. Primary Elements., UR.2. User Requirements**

23 **Item Under Consideration:**

24 Amend Handbook 44, Vehicle Tank Meter Code as follows:

25 **S.1.1. Primary Element**

26 **S.1.1.1. General.** – A meter shall be equipped with a primary indicating element. ~~and may also be~~
27 ~~equipped with a primary recording element.~~ Except for systems used solely for the sale of aviation fuel
28 into aircraft and for aircraft-related operations, a meter shall be equipped with a primary recording
29 element.

30 (Amended 1993 ~~and 20XX~~)

31 ~~**Note:** Except for systems used solely for the sale of aviation fuel into aircraft and for aircraft related~~
32 ~~operations, vehicle tank meters shall be equipped with a primary recording element as required by~~
33 ~~paragraph UR.2.2. **Ticket Printer; Customer Ticket. Recorded Representation**~~

34 (~~Amended 1993 ~~and 20XX~~~~)

35 ...

1 **S.1.4.2. ~~Printed Ticket, Recorded Representation.~~** – If a computing-type device issues a ~~printed ticket~~
2 **recorded representation** which displays the total computed price, the ~~ticket recorded representation~~ shall
3 **also have printed clearly thereon record** the total quantity of the delivery, the appropriate fraction of the
4 quantity, and the price per unit of quantity.
5 (Amended 1989, **and 20XX**)

6 ...

7 **UR.2. User Requirements.**

8 ...

9 **UR.2.2. ~~Ticket Printer, Customer Ticket Recording Element.~~** – Vehicle-Mounted metering systems shall
10 be equipped with a ~~ticket printer which shall be used for~~ **means to record** all sales where product is delivered
11 through the meter **and shall comply with G-S.5.6.** A copy of the ticket issued by the device shall be ~~left with~~
12 **provided to** the customer at the time of delivery or as otherwise specified by the customer.
13 (Added 1993) (Amended 1994, **and 20XX**)

14 **B4: LPG-21.1 D S.1.1. Primary Elements., UR.2. User Requirements**

15 **Item Under Consideration:**

16 Amend Handbook 44, LPG and Anhydrous Ammonia Liquid-Measuring Devices Code as follows:

17 **S.1.1. Primary Elements.**

18 **S.1.1.1. General.** – A meter shall be equipped with a primary indicating element and may also be equipped
19 with a primary recording element.

20 **Note:** Vehicle-mounted metering systems shall be equipped with a primary recording element as required
21 by paragraph UR.2.6. ~~Ticket Printer; Customer Ticket~~ **Recorded Representation**
22 **(Amended 20XX)**

23 ...

24 **S.1.1.6. ~~Printed Ticket, Recorded Representation~~** – Any ~~printed ticket issued~~ **recorded representation**
25 **created** by a device of the computing type ~~on~~ which ~~there is printed~~ **includes** the total computed price, shall
26 ~~have printed clearly~~ **also include** thereon the total volume of the delivery in terms of liters or gallons, and
27 the appropriate decimal fraction of the liter or gallon, and the corresponding price per liter or gallon.
28 (Added 1979) (Amended 1987, **and 20XX**)

29 ...

30 **S.1.5.5. Recorded Representations for Transactions Where a Post-Delivery Discount(s) is**
31 **Provided.** – Except for fleet sales and other price contract sales, a ~~printed receipt~~ **recorded representation**
32 providing the following information shall be available through a built-in or separate recording element that
33 is part of the system for transactions involving a post-delivery discount:

- 34 (a) the product identity by name, symbol, abbreviation, or code number;
- 35 (b) transaction information as shown on the dispenser at the end of the delivery and prior to any post-
36 delivery discount(s), including the:

- 1 (1) total volume of the delivery;
- 2 (2) unit price; and
- 3 (3) total computed price of the fuel sale.
- 4 (c) an itemization of the post-delivery discounts to the unit price; and
- 5 (d) the final total price of the fuel sale after all post-delivery discounts are applied.

6 (Added 2016) (**Amended 20XX**)

7 ...

8 **UR.2. User Requirements.**

9 ...

10 **UR.2.6. ~~Ticket Printer, Customer Ticket. Recorded Representation~~** – Vehicle-Mounted metering
11 systems shall be equipped with ~~a ticket printer which shall be used for means to record~~ all sales where product
12 is delivered through the meter **and shall comply with G-S.5.6.** A copy of the ~~ticket recorded representation~~
13 issued by the device shall be ~~left with~~ **provided to** the customer at the time of delivery or as otherwise specified
14 by the customer.

15 (Added 19932) (Amended 1994, **and 20XX**)

16 ...

17 **UR.2.7.2. Computing Device.** – Any computing device used in an application where a product or grade is
18 offered for sale at one or more unit prices shall be used only for sales for which the device computes and
19 displays the sales price for the selected transaction. The following exceptions apply:

- 20 (a) Fleet sales and other price contract sales are exempt from this requirement.
- 21 (b) A truck stop dispenser used exclusively for refueling trucks is exempt from this requirement
22 provided that:
 - 23 (1) all purchases of fuel are accompanied by a ~~printed receipt~~ **recorded representation** of the
24 transaction containing the applicable price per unit of measure, the total quantity delivered, and
25 the total price of the sale; and
 - 26 (2) unless a dispenser complies with S.1.5.1. Display of Unit Price, the price posted on the
27 dispenser and the price at which the dispenser is set to compute shall be the highest price for
28 any transaction which may be conducted.
- 29 (c) A dispenser used in an application where a price per unit discount is offered following the delivery
30 is exempt from this requirement, provided the following conditions are satisfied:
 - 31 (1) the unit price posted on the dispenser and the unit price at which the dispenser is set to compute
32 shall be the highest unit price for any transaction;
 - 33 (2) all purchases of fuel are accompanied by a receipt recorded by the system for the transaction
34 containing:
 - 35 a. the product identity by name, symbol, abbreviation, or code number;

- 1 b. transaction information as shown on the dispenser at the end of the delivery and prior to
- 2 any post-delivery discount including the:
 - 3 1. total volume of the delivery;
 - 4 2. unit price; and
 - 5 3. total computed price of the fuel sale prior to post-delivery discounts being applied.
- 6 c. an itemization of the post-delivery discounts to the unit price; and
- 7 d. the final total price of the fuel sale after all post-delivery discounts are applied.

8 (Added 2016) (Amended 20XX)

9 **B4: CLM-21.1 D S.1.4.1. ~~Printed Ticket~~ Recorded Representation., UR.2.6.3. ~~Printed~~**
 10 **~~Ticket~~ Recorded Representation.**

11 **Item Under Consideration:**

12 Amend Handbook 44, Cryogenic Liquid-Measuring Devices Code as follows:

13 **S.1.4.1 ~~Printed Ticket~~ Recorded Representation** – Any ~~printed ticket~~ recorded representation issued
 14 by a device of the computing type ~~on which there is printed~~ includes the total computed price, shall ~~have printed~~
 15 ~~clearly thereon~~ also include the total quantity of the delivery, and the price per unit.

16 (Amended 20XX)

17 And

18 **UR.2.6.2. ~~Tickets or Invoices. Recorded representation~~** – Any ~~written invoice, or printed ticket,~~ recorded
 19 representation based on a reading of a device that is equipped with an automatic temperature or density
 20 compensator shall have shown thereon that the quantity delivered has been adjusted to the quantity at the NBP of
 21 the specific cryogenic product or the equivalent volume of gas at NTP.

22 (Amended 20XX)

23 **UR.2.6.3. ~~Printed Ticket. Recorded Representation.~~** – Any ~~printed ticket issued~~ recorded representation
 24 provided by a device of the computing type ~~on which there is printed~~ includes the total computed price, the
 25 total quantity of the delivery, or the price per unit, shall also ~~show~~ include the other two values. ~~(either printed~~
 26 ~~or in clear hand script).~~ and shall comply with G-S.5.6.

27 (Amended 20XX)

28 **B4: MLK-21.1 D S.1.4.2. ~~Printed Ticket~~ Recorded Representation., UR.2.6.3. ~~Printed~~**
 29 **~~Ticket~~ Recorded Representation.**

30 **Item Under Consideration:**

31 Amend Handbook 44, Milk Meter Code as follows:

32 **S.1.4.2. ~~Printed Ticket~~ Recorded Representation** – If a computing-type device issues a ~~printed ticket~~
 33 recorded representation which ~~displays~~ includes the total computed price, the ~~ticket recorded~~
 34 representation shall ~~also have printed clearly thereon~~ include the total quantity of the delivery, the
 35 appropriate fraction of the quantity, and the price per unit of quantity.

36 (Amended 1989, and 20XX)

1 **UR.2.2. ~~Printed Ticket. Recorded Representation.~~** – Any ~~printed ticket issued~~ **recorded representation**
2 **created** by a device of the computing type ~~on~~ which ~~there is printed~~ **includes** the total computed price, the total
3 quantity, or the price per unit of quantity, shall also ~~show~~ **include** the other two values (~~either printed or in clear~~
4 ~~hand script~~). **and shall comply with G-S.5.6.**
5 **(Amended 1989 and 20XX)**

6 **B4: MFM-21.2 D S.6. ~~Printer Recorded Representations., UR.2.6. Ticket Printer, Customer~~**
7 **~~Ticket, Recorded Representation., UR.3.4. Printed Ticket, Recorded~~**
8 **~~Representation.~~**

9 **Item Under Consideration:**

10 Amend Handbook 44, Mass Flow Meter Code as follows:

11 **S.6. ~~Printer. Recording Element~~** – When an assembly is equipped with means for ~~printing~~ **recording** the
12 measured quantity, the following conditions apply:

- 13 (a) the scale interval shall be the same as that of the indicator;
- 14 (b) the value of the ~~printed~~ **recorded** quantity shall be the same value as the indicated quantity;
- 15 (c) *the ~~printed~~ **recorded** quantity shall also include the mass value if the mass is not the indicated quantity;*
16 *[Nonretroactive as of January 1, 2021]*
- 17 (d) a quantity for a delivery (other than an initial reference value) cannot be recorded until the measurement
18 and delivery has been completed;
- 19 (e) the ~~printer~~ **recording element** is returned to zero when the resettable indicator is returned to zero; and
- 20 (f) the ~~printed~~ **recorded** values shall meet the requirements applicable to the indicated values.

21 **(Amended 2016, and 20XX)**

22 **S.6.1. ~~Printed Receipt Recorded Representations.~~** – ~~Any~~ **When a quantity is** delivered, ~~printed~~
23 **quantity** ~~the recorded representation~~ shall include an identification number, the time and date, and the name
24 of the seller. This information may be printed by the device or pre-printed on the ticket.
25 **(Amended 20XX)**

26 And

27 **UR.3.3 ~~Ticket Printer, Customer Ticket, Recorded Representation.~~** – Vehicle-Mounted metering
28 systems shall be equipped with ~~a ticket printer which shall be used for~~ **means to record** all sales where
29 product is delivered through the meter ~~and shall comply with G-S.5.6.~~ A copy of the ~~ticket~~ **recorded**
30 **representation** issued by the device shall be ~~left with~~ **provided to** the customer at the time of delivery or as
31 otherwise specified by the customer.

32 **(Added 19934) (Amended 20XX)**

33 ...

34 **UR.3.4. ~~Printed Ticket. Recorded Representation.~~** – The total price, the total quantity of the delivery, and
35 the price per unit shall be ~~printed~~ **provided** on any ~~ticket~~ **recorded representation** issued by a device of
36 the computing type and containing any one of these values.

37 **(Added 1993) (Amended 20XX)**

1 **B4: CDL-21.1 D S.1.4.1. ~~Printed Ticket~~Recorded Representations., UR.2.4.2. ~~Tickets or~~**
2 **~~Invoices. Recorded Representation.~~**

3 **Item Under Consideration:**

4 Amend Handbook 44, Carbon Dioxide Liquid-Measuring Devices Code as follows:

5 **S.1.4.1. ~~Printed Ticket. Recorded Representation~~**– Any ~~printed ticket recorded representation~~ issued by a
6 device of the computing type ~~on~~ which ~~there is printed~~ **includes** the total computed price shall ~~have printed~~
7 ~~clearly thereon~~ also **include** the total quantity of the delivery and the price per unit.
8 **(Amended 20XX)**

9 **UR.2.4.2. ~~Tickets or Invoices Recorded Representation.~~** – Any ~~written invoice or printed ticket recorded~~
10 ~~representation~~ based on a reading of a device that is equipped with an automatic temperature or density
11 compensator shall ~~have shown thereon~~ **include** that the quantity delivered has been temperature or density
12 compensated.
13 **(Amended 20XX)**

14 **B4: HGM-21.1 D S.2.6. Recorded Representations, Point of Sale Systems., S.6. Printer.**
15 **Recording Element., UR.3.2. Vehicle-mounted Measuring Systems Ticket**
16 **Printer Recording Element., UR.3.3. Printed Ticket. Recorded**
17 **Representation.**

18 **Item Under Consideration:**

19 Amend Handbook 44, Hydrogen Gas-Measuring Devices Code as follows:

20 **S.2.6. Recorded Representations, Point of Sale Systems.** – A ~~printed~~ receipt shall be available through
21 a built-in or separate recording element for transactions conducted with point-of-sale systems or devices activated
22 by debit cards, credit cards, and/or cash. The ~~printed~~ receipt shall contain the following information for products
23 delivered by the dispenser:

- 24 (a) the total mass of the delivery;
 - 25 (b) the unit price;
 - 26 (c) the total computed price; and
 - 27 (d) the product identity by name, symbol, abbreviation, or code number.
- 28 **(Amended 20XX)**

29 **...**

30 **S.6. ~~Printer. Recording Element~~** – When an assembly is equipped with means for ~~printing-recording~~ the
31 measured quantity, the ~~printed recorded~~ information must agree with the indications on the dispenser for the
32 transaction and the ~~printed recorded~~ values shall be clearly defined.
33 **(Amended 20XX)**

34 **S.6.1. ~~Printed Receipt. Recorded Representation~~** – ~~Any~~ **When a quantity is delivered, printed**
35 **quantity the recorded representation** shall include an identification number, the time and date, and the name
36 of the seller. ~~This information may be printed by the device or pre-printed on the ticket.~~
37 **(Amended 20XX)**

38 And

1 **UR.3.2. Vehicle-mounted Measuring Systems ~~Ticket Printer~~ Recording Element.**
2 **(Amended 20XX)**

3 **UR.3.2.1. ~~Customer Ticket~~ Recording Element.** – Vehicle-Mounted metering systems shall be equipped
4 with ~~a ticket printer which shall be used for~~ **means to record** all sales where product is delivered through
5 the device ~~and shall comply with G-S.5.6.~~ A copy of the ~~ticket~~ **recorded representation** issued by the
6 device shall be ~~left with~~ **provided to** the customer at the time of delivery or as otherwise specified by the
7 customer.

8 **(Amended 20XX)**

9 ...

10 **UR.3.3. ~~Printed Ticket, Recorded Representation~~.** – The total price, the total quantity of the delivery, and
11 the price per unit shall be ~~printed~~ **provided** on any ~~ticket~~ **recorded representation** issued by a device of the
12 computing type and containing any one of these values.

13 ~~(Added 1993)~~ **(Amended 20XX)**

14 **B4: OTH-21.2 D Appendix D - Definitions.: recorded representations, recording element.**

15 **Item Under Consideration:**

16 Amend Handbook 44, Appendix D - Definitions as follows:

17 **recorded representation.** – The printed, embossed, **electronic**, or other representation that is recorded as a
18 quantity, **unit price, total price, product identity or other information required** by a weighing or measuring
19 device. [1.10, 2.20, 2.21, 2.22, 2.24, 2.25, 3.30, 3.31, 3.32, 3.33, 3.34, 3.35, 3.36, 3.37, 3.38, 3.39, 3.40, 5.54,
20 5.55, 5.56(a), 5.56(b), 5.57, 5.58, 5.60]

21 **recording element.** – An element incorporated in a weighing or measuring device by means of which ~~its~~ **the**
22 **device's** performance relative to quantity or money value is permanently recorded ~~electronically or~~ on a tape,
23 ticket, card, or the like, in the form of a printed, stamped, punched, or perforated representation ~~or recorded~~
24 **electronically in instances where that option is permitted by specific code.** [1.10, 2.20, 2.21, 2.22, 2.24, 2.25,
25 3.30, 3.31, 3.32, 3.33, 3.34, 3.35, 3.36, 3.37, 3.38, 3.39, 3.40, 5.54, 5.55, 5.56(a), 5.56(b), 5.57, 5.58, 5.60]

26 **Previous Action:**

- 27 • 2021: Developing
- 28 • 2022: Developing

29 **Original Justification:**

30 In 2014 G-S.5.6. was added to Handbook 44 to allow for the issuance of electronic receipts. At that time the use of
31 the term “print”, and all variations on the word “print” was not fully addressed.

32 The Oxford Dictionary defines print as “a mechanical process involving the transfer of text, images, or designs to
33 paper.”

34 The Oxford Dictionary defines record as: to “set down in writing or some other permanent form for later reference,
35 especially officially.”

36 Values that are delivered via electronic means are recorded values and not necessarily printed vales. Printed indicates
37 that a value has been transferred on to a hard document. While the intent of the 2014 amendment was to allow for the
38 use of electronic receipts the terminology used is incorrect. In addition to receipts, there are instances where other
39 information may be transmitted electronically.

40 When applying G-A.2. to weighing and measuring devices,

1 **G-A.2. Code Application.** – *This General Code shall apply to all classes of devices as covered in the specific*
 2 *codes. The specific code requirements supersede General Code requirements in all cases of conflict.*
 3 *(Amended 1972),*

4 Multiple conflicts arise in the implementation of the 2014 Amendment of G-S.5.6. This is to clarify the terminology
 5 in Handbook 44 and to recognize the changing technology in how transactions are recorded, and the information is
 6 disseminated.

7 **Item Development:**

8 This item has been assigned to the submitter for further development. For more information or to provide comment,
 9 please contact:

10 Mr. Charles Stutesman
 11 Kansas Department of Agriculture
 12 785-564-6683 charles.stutesman@ks.gov

13 NOTE: The proposal as it appeared in the 2021 Interim Meeting agenda is available at
 14 <https://www.ncwm.com/interim-archive>.

15 **Comments in Favor:**

16 **Regulatory:**

- 17 • 2021 Interim: Mr. Charles Stutesman (KS), submitter of the item, agreed that the item should be
 18 developing and noted that updates to the item under consideration were provided to the S&T Committee
 19 based on reviews that he had with NIST, OWM.
- 20 • 2021 Annual: Mr. Charles Stutesman (KS) looks forward to maintaining developing status between now
 21 and Interim. When electronic receipt provision was put in GC, it works well but specific codes
 22 supersede. All the sections in this block have printer requirements. The goal was not to remove printers
 23 but to add the option for electronic receipts if customer wants it. He would appreciate comments on how
 24 to clean up the proposal.
- 25 • 2022 Interim: The submitter of the item commented the item needs editing and further work before
 26 voting. Recommends the item remain developing.
- 27 • 2022 Interim: A regulator from California DMS recommends the item remain developing.

30 **Industry:**

- 31 • 2021 Interim: Mr. Dmitri Karimov (MMA) commented that the proposed changes to recognize
 32 electronically captured tickets are needed, editorial corrections are needed to some parts of the proposal,
 33 and he agreed with a developing status for this item.
- 34 • 2022 Interim: A member of industry representing MMA commented general support with some edits to
 35 the language and supports further development.
- 36 • 2022 Interim: A member of industry representing SMA supports the item, as it recognizes the importance
 37 of providing flexible options for recorded representations to customers and sees value in the item as
 38 developing.

39 **Advisory:**

- 40 • 2021 Interim: Ms. Diane Lee (NIST OWM) commented that there are two proposed changes to HB 44,
 41 Mass Flow Meter Code, Paragraph U.R.3.3 in the 2021 Interim Agenda. One proposal is Block 4 MFM-
 42 21.2 UR.3.3. (which was incorrectly number as UR.2.6 in the item under consideration in the 2021
 43 Interim Meeting agenda) and the other is item MFM-21.1. UR.3.3. on the 2021 Interim Meeting agenda.
 44 The submitters should work together to provide one proposed change.

- 1 • 2022 Interim: An advisory member representing NIST OWM agrees with the need to address current
2 language in the proposal and supports development.

3 **Comments Against:**

4 **Regulatory:**

- 5 • 2022 Interim: No comments heard.

6 **Industry:**

- 7 • 2022 Interim: No comments heard.

8 **Advisory:**

- 9 • 2022 Interim: No comments heard.

10

11 **Neutral Comments:**

12 **Regulatory:**

- 13 • 2022 Interim: No comments heard.

14 **Industry:**

- 15 • 2022 Interim: No comments heard.

16 **Advisory:**

- 17 • 2022 Interim: No comments heard.

18

19 **Item Development:**

20 NCWM 2022 Interim Meeting: The Committee assigned a developing status for this item at the 2022 Interim Meeting.
21 The committee supports the work and recommends the continued work with all stakeholders. For more information
22 or to provide comment, please contact:

23 Mr. Charles Stutesman
24 Kansas Department of Agriculture
25 785-564-6683 charles.stutesman@ks.gov

26 NOTE: The proposal as it appeared in the 2021 Interim Meeting agenda is available at
27 <https://www.ncwm.com/interim-archive>.

28 NCWM 2022 Annual Meeting: During open hearings, the Committee received an update from submitter Charlie
29 Stutesman, Kansas. Mr. Stutesman is working with NIST while continuing to develop the items. The submitter
30 requests developing status as well as written feedback from interested parties while he works on the specific language
31 of the items.

32 **Regional Associations' Comments:**

33 WWMA 2021 Annual Meeting: Matt Douglas (California - DMS): California supports further development of the
34 block. Russell Vires (SMA): SMA supports 2 of the items GEN-21.2, OTH-21.2. Diane Lee (NIST OWM): carryover
35 item. NIST has comments on this item posted. They support it as a developing item going forward.

36

37 The WWMA S&T Committee recommends the status remain developmental. The Committee recommends that the
38 submitter continue to work with NIST OWM to further develop the item.

39 SWMA 2021 Annual Meeting: Russ Vires, SMA, stated that he supports this item. Tim Chesser, State of Arkansas,
40 suggested changing the wording in Gen 21.1. His suggestion is to change “presented” to “available”.

41

1 This committee recommends this item remain Developing, so they have an opportunity to work with the NIST OWM
 2 to clarify and clean up the language.

3 CWMA 2021 Interim Meeting: Russ Vires – SMA - The SMA supports this item. The SMA recognizes the importance
 4 of providing flexible options for recorded representations to the consumer.

5 NEWMA 2021 Interim Meeting: Mr. Russ Vires (SMA) rose in support of GEN-21.2 and OTH-21.2. He commented
 6 that he supports the option for electronic receipts and tickets, and recognizes the need to provide options for
 7 consumers. No other comments were heard on this block.

8
 9 After hearing comments from the floor, the committee recognized the need to further develop this block and
 10 recommended the block retain developing status.

11 Additional letters, presentation and data may have been submitted for consideration with this item. Please refer to
 12 www.ncwm.com/publication-15 to review these documents.

ITEM BLOCK 4
<p>Regional recommendation to NCWM on item status:</p> <ul style="list-style-type: none"> <input type="checkbox"/> Recommend as a Voting Item on the NCWM agenda <input type="checkbox"/> Recommend as an Information Item on the NCWM agenda <input type="checkbox"/> Recommend as an Assigned Item on the NCWM agenda <i>(To be developed by an NCWM Task Group or Subcommittee)</i> <input checked="" type="checkbox"/> Recommend as a Developing Item on the NCWM agenda <i>(To be developed by source of the proposal)</i> <input type="checkbox"/> Recommend Withdrawal of the Item from the NCWM agenda <i>(In the case of new proposals, do not forward this item to NCWM)</i> <input type="checkbox"/> No recommendation from the region to NCWM <i>(If this is a new proposal, it will not be forwarded to the national committee by this region)</i>
<p>Comments and justification for the regional recommendation to NCWM: <i>(This will appear in NCWM reports)</i></p> <p>No comments were received on this item during the 2022 SWMA Annual Meeting.</p> <p>The SWMA S&T Committee recommends this item remain as a Developing Item.</p>

13

14 **BLOCK 5 ITEMS (B5) TEST DRAFTS**

15 **Source:**
 16 Murray Equipment, Inc./Total Control Systems.

17 **Purpose:**
 18 Change the word “should” to “shall” to clarify the importance of using a calibrated container of adequate size to accept
 19 a “test draft of at least the amount delivered by the device in 1 minute at its maximum discharge rate” where it is
 20 referenced in Handbook 44 Vehicle-Tank Meters and the Liquid Measuring Devices codes.

21 **B5: LMD-23.2 N.3.5. Wholesale Devices**

22 **Item Under Consideration:**
 23 Amend Handbook 44, Liquid Measuring Devices Code as follows:

1 N.3.5. Wholesale Devices. - The delivered quantity ~~should~~shall be equal to at least the amount delivered by
2 the device in one minute at its maximum discharge rate and shall in no case be less than 200L (50 gal).

3 **B5: VTM-23.2 N.3. Test Drafts**

4 **Item Under Consideration:**

5 Amend Handbook 44, Vehicle Tank Meters Code as follows:

6 N.3. Test Drafts. (VTM Code) – Test drafts ~~should~~shall be equal to at least the amount delivered by the device
7 in 1 minute at its maximum discharge rate and shall in no case be less than 180 L (50 gal) or 225 kg (500 lb).

8 **Previous Action:**

9 2023: New Items

10
11 **Original Justification:**

12 In some locations, the largest available prover for fuel field testing is 100 gallons. In high flow situations over 100
13 gpm, the 100-gallon prover does not meet requirement of HB44. Inspectors are using what they have and doing the
14 best they can. However, using a proving can smaller than what is recommended in HB44 can lead to errors in the
15 field including failing an accurate metering system that would have been approved if the draft size was the correct
16 size. In fact, we have experienced situations where mechanical registers are favored over electronic registers when
17 smaller than recommended size test drafts are used due to inspectors visually estimating fractions of gallons on a
18 mechanical register that reads out in whole gallons while only reading in whole gallons on electronic registers set to
19 read in whole gallons.

20
21 In the following example, there is an aircraft refueler that normally operates at 300 GPM through a standard aircraft
22 underwing fueling nozzle. The inspector is using the over-wing nozzle at 100 GPM in the available 100-gallon
23 proving can to test the system. The customer wants the meter to display in whole gallons due to the high delivery
24 speed and large volume of delivered fuel per transaction when fueling aircraft at 300 GPM. Because the VTM code
25 says the test draft “should” be equal to at least the amount delivered by the device in 1 minute at its maximum discharge
26 rate, the inspector felt comfortable using the 100-gallon proving can rather than securing a 300-gallon or larger proving
27 can.

28
29 Besides feeling empowered to use a proving can smaller than the recommended size, the inspector also interpreted the
30 text from N.4.1 Normal Tests. – “...under the conditions of the installation” to mean that the meter display could not
31 be changed to indicate decimal points, but rather must be left on whole gallons. Most likely the meter with electronic
32 display would have passed this “non-normal” test if the display would have been set to tenths or hundredths of gallons
33 for the test draft. The ½ gallon of potential rounding error caused by the whole gallon display introduced an additional
34 system error of up to 0.5% on a 100-gallon prover, which make is nearly impossible to pass a test with +/- 0.2% of
35 allowable error.

36
37 In the example above, the inspector set conditions that encouraged high variability in the system accuracy and
38 precision. When questioned about the test draft conditions, the inspector referred to the Handbook 44 code,
39 interpreting it to allow the undersized proving can and not allow meter display decimal changes. Changing Handbook
40 44 text from “should” to “shall” will prevent undersize test drafts. It is also important to clarify what “...under the
41 conditions of the installation” specifically refers to; that is, the fluid path elements such as hose length, hose type,
42 nozzle setting, system valve settings, etc. Metering systems with electronic digital displays should not be handicapped
43 due to being set for whole gallons or tenths of gallons especially if the proving can used is smaller than what is required
44 or recommended by Handbook 44.

45
46 One of the technological advancements of electronic registers over mechanical registers is the option of quickly and
47 easily changing the number of decimal points shown on the display. Something that literally takes seconds to do on
48 an electronic register is cumbersome, time consuming, and generally not recommended outside of a factory on
49 mechanical registers. With very few exceptions, customers, distributors, and manufacturers favor electronic registers
50 due to improved features, improved durability and accuracy. Mechanical registers, on the other hand, are becoming

1 obsolete and should not be given preference due to a misunderstanding of the meaning of the phrase "...under the
2 conditions of the installation."

3 The submitter acknowledges the following arguments:

- 4 1) **Some locations don't have access to calibration containers large enough to hold the required test draft**
5 **size.** In this case, the correct size calibration container should be borrowed or rented to meet HB44
6 requirements.
- 7 2) **Everything is fine with the current code text, don't change it.** The problem is that everything is NOT fine
8 now. Due to the soft "should" language rather than the un-negotiable "shall" language, inspectors do from
9 time to time use smaller than recommended proving cans that can lead to failing an accurate metering system
10 or approving an inaccurate system.
- 11 3) **Inspectors know it is OK to change the decimal points for testing when using a calibration container**
12 **that is smaller than is recommended.** In the example above, the inspector would NOT allow the decimal
13 points to be changed for testing, so not all inspectors seem to agree.
- 14 4) **Inspectors may have to break the calibration seal to change the decimal point settings in some situations.**
15 That is why the inspectors have calibration seals.

16 **Requested Status by Submitter:** Not Specified

17 **Comments in Favor:**

18 **Regulatory:**

- 19 •

20 **Industry:**

- 21 •

22 **Advisory:**

- 23 •

24 **Comments Against:**

25 **Regulatory:**

- 26 •

27 **Industry:**

- 28 •

29 **Advisory:**

- 30 •

31 **Neutral Comments:**

32 **Regulatory:**

- 33 •

34 **Industry:**

- 35 •

36 **Advisory:**

- 37 •

1 **Item Development:**

2 New

3 Additional letters, presentation and data may have been submitted for consideration with this item. Please refer to
4 www.ncwm.com/publication-15 to review these documents.

ITEM BLOCK 5	
Regional recommendation to NCWM on item status:	
<input type="checkbox"/> Recommend as a Voting Item on the NCWM agenda <input type="checkbox"/> Recommend as an Information Item on the NCWM agenda <input type="checkbox"/> Recommend as an Assigned Item on the NCWM agenda <i>(To be developed by an NCWM Task Group or Subcommittee)</i> <input type="checkbox"/> Recommend as a Developing Item on the NCWM agenda <i>(To be developed by source of the proposal)</i> <input checked="" type="checkbox"/> Recommend Withdrawal of the Item from the NCWM agenda <i>(In the case of new proposals, do not forward this item to NCWM)</i> <input type="checkbox"/> No recommendation from the region to NCWM <i>(If this is a new proposal, it will not be forwarded to the national committee by this region)</i>	
Comments and justification for the regional recommendation to NCWM: <i>(This will appear in NCWM reports)</i>	
The following comments were received during the 2022 SWMA Annual Meeting: Mr. Keilty, Endress+Hauser, stated that this item represented the confusion over this issue, and is a misapplication. He recommends withdrawal. Mr. Searles, API, stated that he has no issue with should to shall, and that he wasn't sure if this correction would address the submitters problem. The SWMA S&T Committee recommends that this item be Withdrawn.	

5

6 **BLOCK 6 ITEMS (B6) COMMERCIAL AND LAW ENFORCEMENT, AXLE AND**
7 **AXLE GROUP WEIGHTS**

8 **Source:**

9 NIST, Office of Weights and Measures

10 **Purpose:**

11 This proposed change is intended to add clarification regarding the implications of using weighing and measuring
12 devices for transactions that may be considered by some as commercial while there is no clear guidance provided.
13

14 **B6: SCL-22.1 D Recorded Representation of Axle or Axle Group Weights**

15 **Item Under Consideration:** Amend NIST Handbook 44, Scales Code as follows:

16 **S.1.14. Recorded Representations, Multi-Independent Platform¹ Vehicle Scale Systems**

17 **S.1.14.1. Axle and Axle Group Loads. – All recorded representations of the different axle and axle**
18 **group loads of a vehicle weighed on a multi-independent platform vehicle scale system shall be**
19 **identified by providing indication of either:**

1 (a) the portion of the vehicle to which they represent (e.g., “axle-group 1, axle group 2, axle group
2 3,” or if using axle and axle group descriptions, “steering axle, drive axles, trailer axles”), or

3 (b) the particular independent scale platform from which they were obtained (e.g., “Platform 1,
4 Platform 2, Platform 3”).

5 S.1.14.2. Total Vehicle Weight. – If a summed total of all axle and axle group loads of a vehicle
6 weighed on a multi-independent platform vehicle scale system is recorded, the recorded value shall be
7 clearly identified as:

8 (a) “Total Vehicle Weight,” “Vehicle Weight,” (or other similar terms that clearly identify the
9 value as the vehicle’s total weight) providing all axle(s) and axle groups of the vehicle weighed
10 were positioned on a live portion of the weighing/load-receiving elements and weighed
11 simultaneously when the summed total was determined², or

12 (b) “Not-Legal-For-Trade” unless all axle and axle groups of the vehicle weighed were
13 simultaneously positioned on a live portion of the weighing/load-receiving elements when the
14 summed total was determined, or the vehicle was weighed using the alternative method
15 described in footnote 2 of this paragraph.

16 ¹Multi-independent platform means each platform of the scale is a single independent weighing/load-
17 receiving element unattached to adjacent elements and with its own A/D conversion circuitry and displayed
18 weight.

19 ²Alternatively, the individual components of the vehicle being weighed may be uncoupled, positioned
20 completely on the live elements of the scale, weighed separately, and then totaled.

21 *[subsequent requirements to be renumbered as appropriate]*

22 **B6: SCL-22.3 D UR.3.3. Single-Draft Vehicle Weighing., and UR.3.4. Axle and Axle Group**
23 **Weight Values.**

24 **Item Under Consideration:**

25 Amend Handbook 44, Scales Code as follows:

26 **UR.3.3. Single-Draft Vehicle Weighing.** – A vehicle or a coupled-vehicle combination shall be commercially
27 weighed on a vehicle scale only as a single draft. That is, the total weight of such a vehicle or combination shall
28 not be determined by adding together the results obtained by separately and not simultaneously weighing each
29 end of such vehicle or individual elements of such coupled combination. However, the weight of:

30
31 (a) a coupled combination may be determined by uncoupling the various elements (tractor, semitrailer,
32 trailer), weighing each unit separately as a single draft, and adding together the results; or

33
34 (b) a vehicle or coupled-vehicle combination may be determined by adding together the weights obtained
35 while all individual elements are resting simultaneously on more than one scale platform.

36
37 ~~Note: This paragraph does not apply to highway law enforcement scales and scales used for the collection~~
38 ~~of statistical data.~~
39 ~~(Added 1992)~~

40 And

41 **UR.3.4. Axle and Axle Group Weight Values.** – **Weight values of axles or axle groups of highway motor**
42 **vehicles are necessary to verify compliance with highway weight limit enforcement. When a fee is charged**

1 for the use of an axle-load scale or vehicle scale to determine the weight of axles or axle-groups, the
2 transaction is considered to be “commercial” as defined by General Code paragraph G-A.1. Commercial
3 and Law Enforcement Equipment and the scale shall comply with all applicable requirements for
4 commercial weighing systems.

5 When weight values for axles or axle groups are obtained using multiple-platform vehicle scales and where
6 all parts of the motor vehicle are simultaneously resting on live elements of the scale, the weight values for
7 axles or axle groups may be summed together to represent a commercial total gross weight of the motor
8 vehicle. Weight values for axles or axle groups may also be summed to represent a commercial total gross
9 weight of the motor vehicle if the individual components are uncoupled, positioned completely on the live
10 elements, and weighed separately on the scale.

11 Weight values of axles or axle groups obtained from these weighing devices as individual weighing
12 operations where all parts of the motor vehicle are not simultaneously resting on live portions of the scale
13 shall not be used in commercial transactions and may only be used to verify compliance with highway
14 weight limits.

15 Renumber existing paragraphs UR.3.4 through UR.3.12.)

16 **Previous Action:**

17 2022: Developing

18 **Original Justification:**

19 OWM has noted a number of inquiries submitted to our office for explanation on the many and various issues involved
20 with the use of weighing or measuring devices as commercial devices when there is charge for doing so. Law
21 enforcement devices may be regulated in a different manner than commercial devices (e.g., allows highway weight
22 limit enforcement through multi-draft weighing) when commercial devices are not allowed to be used in that way.

23 The submitter pointed out that there seems to be a difference in opinions regarding this practice constitutes a
24 commercial transaction.

25 The submitter requested voting status for these items in 2022.

26 **Comments in Favor:**

27 **Regulatory:**

- 28 • Supported the language alignment of GEN 22.1 with L&R Block 2. Support for separating the blocked
29 items.

30
31 **Industry:**

- 32 • SMA provided written comments and open hearing testimony that the items should be separated.
33 Supports each item, but recommends changes to SCL 22.1
34

35 **Advisory:**

- 36 • NIST (submitter) recommended that GEN 22.1 be separated and given voting status. Asked that
37 remainder of block remain developing.
38

39 **Comments Against:**

40 **Regulatory:**

- 41 •
42

43 **Industry:**

- 44 •
45

46 **Advisory:**

1
2
3
4
5
6
7
8
9
10

Neutral Comments:

Regulatory:

- SCL code sections could be reworded for easier understanding and comprehension of commercial vs. non-commercial.

Industry:

- Recommended that tickets should have identification of axle groups.

Advisory:

Item Development:

11 NCWM 2022 Interim Meeting: During the S&T Committee work session, the committee agreed to remove item GEN
12 22.1 from Block 6. The committee recommendations pertain to the remainder of the block only (SCL 22.1 & SCL
13 22.3). The committee received updated language from the submitter for item SCL 22.1.

15 This item has been assigned to the submitter for further development. For more information or to provide comment,
16 please contact:

17 Mr. Richard Harshman
18 NIST Office of Weights and Measures
19 301-975-8107, richard.harshman@nist.gov

20 NCWM 2022 Annual Meeting: Tina Butcher, NIST OWM is requesting feedback on the two items in Block 6D.
21 Allow additional time for input. Paragraph numbers have been updated in the proposal and amendments have been
22 made since 2022 Interim meeting and are posted on the website.

Regional Associations' Comments:

24 WWMA 2021 Annual Meeting: Kurt Floren (LA County): He wants to offer that the last part of subsection A and
25 breaking into bullet points. He wants to break out equipment that is commercial, then the other types. It's titled
26 commercial and law enforcement then "other commercial" and it becomes confusing. Is it all commercial and subject
27 to our jurisdiction? rephrase GA-1: apply "to commercial equipment as follows: " ... explains that everything under is
28 commercial. (strike "commercial" from A and B). Between apply and as in the first line, insert commercial equipment.
29 Kurt Floren stated that he will submit a written statement to the Committee as presented during open hearings. Ivan
30 Hankins (Iowa): He wants clarification as to what is being changed to make it better. It looks like it's already there,
31 and he wants more definition on why this is changing. Cadence Matijevec (Nevada): Agrees with Kurt but cautions
32 that we consider how the heading reads if we add commercial to the opening statement then there might be some
33 interpretation that what is or is not commercial law enforcement equipment. (is there a fine assessed?) does not want
34 to narrow the subsection of law enforcement devices only to commercial purposes. Kurt Floren (LA County): fix to
35 Cadence Matijevec: restructure under GA-1: insert subsection under 1: commercial as follows, then insert A,B,C
36 then 2 for law enforcement. Cadence Matijevec (Nevada) - states that Kurt is much better at this, and his fix is good.
37 Lou Straub (Fairbanks Scales): agrees with Ivan, that the original language is satisfactory. Language needs to say that
38 its NTEP approved and meet handbook requirements. Eric Golden (Cardinal Scale): does a commercial transaction
39 include just getting a weight: he says yes. Change the wording that that transaction is commercial. No suggestions at
40 this time. Kurt missed a typo: in B2: "Basis." Tina Butcher (NIST OWM); their office submitted this. Wanted to
41 clarify commercial transactions. Agrees with previous testimony. They have submitted other proposals to amend
42 method of sale reg. and uniform law. They have determined that HB44 and 2 sections in HB130 are slightly different.
43 Uniform Reg. for service persons also needs to be aligned. Wants this to remain developing so that they can continue
44 to align the language and make it more uniform. Russell Vires (Scale Manufacturers Association): This is a new item,
45 the SMA has not vetted this yet. They will do so at November meeting. This should remain developing so that there's
46 no unintended consequences. Tina Butcher (NIST OWM): In the agenda, this is blocked with two other "companions".
47 She feels that the block should continue, however, if others think that other items in the block are ready (SCL-22.1
48 and SCL-22.3) those items can move forward. Russell Vires (Scale Manufacturers Association): he is looking at it as
49 a block and is commenting as an entire block. Wants all 3 to remain developing so that they can research. Lou Straub

1 (Fairbank Scales): SCL-22.1: concern about the second sentence: talking about the entire truck on the scale = not
2 legal for trade: this is ok. Second part about axle identifications (axle groups) this gets difficult to identify group
3 notifications. Wants the ticket that has already been marked as not legal for trade to not have to identify all axels.
4 Wants this re-worded. They will put down axle weight and gross weight. Preprinted labels don't allow enough space.
5 Eric Golden (Cardinal Scales): agrees with Tina to split the items. "Blow the block apart." The second two items
6 introduce additional items and topics. Wants to pull the second two items out.

7 The WWMA S&T Committee recommends that this be assigned a Developmental status. The Committee recommends
8 following the submitter's request to remove GEN-22.1 from the Block. Based on testimony heard the Committee
9 agreed to submit the following language for item GEN-22.1. The Committee notes that SCL-22.1 (UR.3.3.) item was
10 reassigned as SCL-22.3.

11
12 **G-A.1. Commercial and Law-Enforcement Equipment.** – These specifications, tolerances, and other
13 technical requirements apply as follows:

14 **(1) To commercial weighing and measuring equipment**

15 (a) ~~To commercial weighing and measuring equipment; that is, to weights and measures and weighing and~~
16 ~~measuring devices commercially used or employed in establishing the size, quantity, extent, area,~~
17 ~~composition (limited to meat and poultry), constituent values (limited to grain), or measurement of~~
18 ~~quantities, things, produce, or articles for distribution or consumption, purchased, offered, or submitted~~
19 ~~for sale, hire, or award, or in computing any basic charge or payment for services rendered on the~~
20 ~~basis of weight or measure.~~

21 (Amended 2008 **and 20XX**)

22 (b) **To other commercial weighing and measuring equipment:**

23 **i. when there is a fee assessed for the use of the equipment to determine a weight or**
24 **measure;**

25 **ii. used to determine the bases of an award using count, weight, or measure; or**

26 **iii. used in computing any basic charge or payment for services rendered on the basis of weight**
27 **or measure**

28 **(Added 20XX)**

29
30 ~~(b)~~ To any accessory attached to or used in connection with a commercial weighing or measuring device
31 when such accessory is so designed that its operation affects the accuracy of the device.

32 ~~(c)~~ **(2)** To weighing and measuring equipment in official use for the enforcement of law or for the collection
33 of statistical information by government agencies.

34 (These requirements should be used as a guide by the weights and measures official when, upon request, courtesy
35 examinations of noncommercial equipment are made.)

36 SWMA 2021 Annual Meeting: Russ Vires, Mettler Toledo, stated that this item needs work on the wording and
37 further review by stakeholders. Its current language could have unintended consequences, and recommended it
38 continue with a Developing Status. This committee would like clarification on the purpose and use of axle weight
39 scale values allowed by this proposal beyond law enforcement use.

40
41 This committee recommends that this item move forward with a Developing status.

42 CWMA 2022 Annual: Russ Vires – SMA - The SMA recommends that Block 6 be broken apart into two (2) individual
43 items. Each of these items deals with a separate topic that needs to be discussed individually. Regarding SCL-22.1:
44 The SMA supports this item with the following changes: "**S.1.14.1. Axle and Axle Group Loads. - All recorded**
45 **representations of the different axle and axle group loads of a vehicle when weighed in a single draft on a multi-**
46 **independent platform vehicle scale system shall be identified by providing indication of either:**"

1 Identifying the recorded weight values for the axle/axle groups as required in S.1.14.1.(a) is only necessary when the
 2 vehicle can be weighed in a single draft.

3 NEWMA 2022 Annual Meeting:

4 Mr. Russ Vires (SMA) recommends Block 6 be broken into two separate items. Mr. Vires indicated his supports this
 5 item with the following language change: S.1.14.1. Axle and Axle Group Loads. - All recorded representations of
 6 the different axle and axle group loads of a vehicle **when weighed in a single draft** on a multi-independent platform
 7 vehicle scale system shall be identified by providing indication of either:. Ms. Tina Butcher (NIST OWM) commented
 8 that this item needs development.

9 After hearing comments from the floor, the committee recognized the need to further develop this block and
 10 recommended the block retain developing status.

11 Additional letters, presentation and data may have been submitted for consideration with this item. Please refer to
 12 www.newm.com/publication-15 to review these documents.

ITEM BLOCK 6
<p>Regional recommendation to NCWM on item status:</p> <ul style="list-style-type: none"> <input type="checkbox"/> Recommend as a Voting Item on the NCWM agenda <input type="checkbox"/> Recommend as an Information Item on the NCWM agenda <input type="checkbox"/> Recommend as an Assigned Item on the NCWM agenda <i>(To be developed by an NCWM Task Group or Subcommittee)</i> <input checked="" type="checkbox"/> Recommend as a Developing Item on the NCWM agenda <i>(To be developed by source of the proposal)</i> <input type="checkbox"/> Recommend Withdrawal of the Item from the NCWM agenda <i>(In the case of new proposals, do not forward this item to NCWM)</i> <input type="checkbox"/> No recommendation from the region to NCWM <i>(If this is a new proposal, it will not be forwarded to the national committee by this region)</i>
<p>Comments and justification for the regional recommendation to NCWM: <i>(This will appear in NCWM reports)</i></p> <p>The following comments were received during the 2022 SWMA Annual Meeting:</p> <p>Mr. Huff, State of Delaware, questioned whether this would allow law enforcement officials to split weigh.</p> <p>The SWMA S&T Committee asks how legal split weighing would be initiated, how it would be recorded on the ticket, would scale operators be required to mark the tickets where split weighing had taken place, or would that be automatically done?</p> <p>The SWMA S&T Committee recommends this item remain as a Developing Item.</p>

13

1 **BLOCK 7 ITEMS (B7) TOLERANCES ON TESTS USING TRANSFER STANDARDS**

2 **Source:**

3 Seraphin Test Measure Company, A Division of Pemberton Fabricators, Inc.

4 **Purpose:**

5 The purpose of these proposals is to change the language in the tolerance paragraphs that already specify that larger
6 tolerances when a transfer standard is used, but that the OIML R117 Reduced MPE formula shall be used. Unless the
7 proposed changes to 2021 S&T Agenda Block 1 Item GEN-19.1. are accepted, these proposals should not proceed.

8 **B7: CLM-22.1 D T.3. On Tests Using Type 2 Transfer Standards.**

9 **Item Under Consideration:**

10 Amend Handbook 44, Cryogenic Liquid-Measuring Devices Code as follows:

11 T.3. **On Tests Using Type 2 Transfer Standards.** – To the basic tolerance values that would otherwise be
12 applied, there shall be added an amount equal to two times the standard deviation of the applicable transfer
13 standard when compared to a basic reference standard. **When commercial meters are tested using a Type**
14 **2 transfer standard, the tolerance applied to the meter under test shall be calculated using the formula**
15 **specified in the General Code Tolerance section.**
16 **(Amended 202X)**

17 **B7: CDL-22.1 D T.3. On Tests Using Type 2 Transfer Standards.**

18 **Item Under Consideration:**

19 Amend Handbook 44, Carbon Dioxide Liquid-Measuring Devices Code as follows:

20 **T.3. On Tests Using Type 2 Transfer Standards.** – To the basic tolerance values that would otherwise be
21 applied, there shall be added an amount equal to two times the standard deviation of the applicable transfer
22 standard when compared to a basic reference standard. **When commercial meters are tested using a Type 2**
23 **transfer standard, the tolerance applied to the meter under test shall be calculated using the formula**
24 **specified in the General Code Tolerance section.**
25 **(Amended 202X)**

26 **B7: HGM-22.1 D T.4. Tolerance Application on Tests Using Type 2 Transfer Standard Test**
27 **Method.**

28 **Item Under Consideration:**

29 Amend Handbook 44, Hydrogen Gas-Measuring Devices Code as follows:

30 **T.4. Tolerance Application on Tests Using Transfer Standard Test Method.** – To the basic tolerance values
31 that would otherwise be applied, there shall be added an amount equal to two times the standard deviation of the
32 applicable transfer standard when compared to a basic reference standard. **When commercial meters are**
33 **tested using a Type 2 transfer standard, the tolerance applied to the meter under test shall be calculated**
34 **using the formula specified in the General Code Tolerance section.**
35 **(Amended 202X)**

36 **Previous Action:**

37 2022: Developing

38 **Original Justification:**

39 In the codes mentioned above, when transfer standards are used, the basic tolerances to be applied to the devices under
40 test are to be increased by the uncertainty of the transfer standard (i.e., two times the standard deviation of the transfer

1 standard). The proposed changes incorporate the OIML R117 formula to state how the tolerance is to be increased
 2 when transfer standards are used. The formula effectively places an upper limit on how large the uncertainty
 3 associated with the transfer standard can be.

4 This item has been assigned to the submitter for further development. For more information or to provide comment,
 5 please contact:

6 Mr. Bob Murnane
 7 Seraphin Test Measure Co.
 8 609-267-922, rmurnane@pemfab.com

9 The current paragraphs already state that, when transfer standards are used, the tolerances are to be increased by two
 10 standard deviations for the repeatability of the transfer standard. One can argue that effect of the proposed changes is
 11 small and not necessary. The proposed changes are intended to provide consistency with the changes proposed in the
 12 amended proposals of 2021 S&T Agenda Block 1 Item GEN-19.1.

13 The submitter requested that this be a Voting Item in 2022.

14 **Comments in Favor:**

15 **Regulatory:**

- 16 •

17 **Industry:**

- 18 • Bob Murnane (Seraphin) explained the addition of “Type 2” term.

19 **Advisory:**

- 20 •

21 **Comments Against:**

22 **Regulatory:**

- 23 •

24 **Industry:**

- 25 • A revised version by Seraphin (submitter) was presented and made available on the NCWM website to
 26 properly align with GEN 19.1. The submitter requests that Block 7, Gen 19.1 and related item OTH
 27 21.1 follow the same path moving forward.
- 28 • Dmitri Karimov (Liquid Controls) commented that the Block is linked to GEN 19.1 due to definition
 29 of Type 1 and 2 transfer standards. Mr. Karamov said it seems odd to single out Type 2. He explained
 30 T.1-3 restates what’s in GEN 19.1 and recommends the Block to be withdrawn and GEN 19.1 move
 31 forward.

32 **Advisory:**

- 33 •

34 **Neutral Comments:**

35 **Regulatory:**

- 36 • Matt Douglas (California) recommends this Block and the associated items be given developing status.

37 **Industry:**

- 1 • Dmitri Karimov representing the Meter Manufacturers Association (MMA) stated that there was no
2 consensus within the MMA.

3 **Advisory:**

- 4 • Diane Lee (NIST, OWM) who provided a brief overview of the written NIST analysis, which can be
5 found on the NCWM website. This item is related to GEN 19.1 and OTH 22.1.

6 **Item Development:**

7 NCWM 2022 Interim Meeting: The committee recommended that this item be given a developing status to allow the
8 submitter to work on it. Since the 2022 interim meeting, the submitter has made additional changes to the items under
9 consideration which are currently reflected in Block 7 above. These changes reference using the specific formula in
10 the general code tolerance section, rather than a formula specified here.

11 NCWM 2022 Annual Meeting: Seraphin was not present but submitted comments in writing to update the Items
12 under Consideration.

13 **Background and Discussion:**

14 Seraphin and NIST OWM are working together in a joint effort to address changes to Block 7 items which are impacted
15 by changes being made to GEN-19.1. Seraphin made changes to the Block 7 items that appear in the 2022 Interim
16 Meeting Agenda to make it clear that the tolerances apply to Type 2 transfers standards as stated in the definitions
17 included in the combined proposal GEN-19.1 and OTH-22.1. Additionally, the tolerances in the specific codes refer
18 to the NIST HB 44 General Code Tolerance section rather than providing the equation in each Tolerance section in
19 the Liquid Measuring Devices Code, Carbon Dioxide Liquid-Measuring Devices, and Hydrogen Gas-Measuring
20 Devices Code. Although changes will be needed to the Taximeter and Transportation Network Measuring Systems
21 Code, Block 7 is limited to measuring devices and if these changes are accepted, other industry sectors will be involved
22 in making similar changes as they apply to their specific Handbook 44 codes.

23 If the S&T Committee presents the combined item GEN-19.1 and OTH-22.1 for a vote in 2022, then this item may
24 also go forward for a vote in 2022.

25 **Regional Associations' Comments:**

26 WWMA 2021 Annual Meeting: Bob Murnane (Seraphin): submitter: this needs to go with the GEN-19. Marc Buttler
27 (Emerson Micro Motion): wants to re-state : earlier comment on GEN item would also apply to calculation on this.
28 He will adjust the calculation to increasing tolerance from decreasing. Bob Murnane (Seraphin): they have looked at
29 original comments in GEN 19: they will have info for us shortly. A letter was submitted to the Committee by Marc
30 Buttler (Emerson Micro Motion) and will be posted to the WWMA website.

31 The WWMA S&T Committee recommends that this Block be assigned a developmental status. The Committee
32 recommends that item GEN-19.1 be inserted into Block 7.

33 SWMA 2021 Annual Meeting: Mr. Oppermann, Seraphin, stated that this item is related to Gen 19.1, and should not
34 move forward unless Gen 19.1 moves forward as well.

35 This committee recommends this item be assigned Developing status.

36 CWMA 2022 Annual Meeting: Bob Murnane – Seraphin - Remain developing, can't move to voting item unless
37 OTH-22.1 does move to voting.

38
39 The CWMA S&T Committee recommends this moves forward as a voting item, with the understanding that Block 8
40 must first pass.

41 NEWMA 2022 Annual Meeting: No comments were heard from the body on this item, however, the committee
42 recognizes the need to further develop this block.

1 Additional letters, presentation and data may have been submitted for consideration with this item. Please refer to
 2 www.ncwm.com/publication-15 to review these documents.

ITEM BLOCK 7
<p>Regional recommendation to NCWM on item status:</p> <p> <input type="checkbox"/> Recommend as a Voting Item on the NCWM agenda <input type="checkbox"/> Recommend as an Information Item on the NCWM agenda <input type="checkbox"/> Recommend as an Assigned Item on the NCWM agenda <i>(To be developed by an NCWM Task Group or Subcommittee)</i> <input checked="" type="checkbox"/> Recommend as a Developing Item on the NCWM agenda <i>(To be developed by source of the proposal)</i> <input type="checkbox"/> Recommend Withdrawal of the Item from the NCWM agenda <i>(In the case of new proposals, do not forward this item to NCWM)</i> <input type="checkbox"/> No recommendation from the region to NCWM <i>(If this is a new proposal, it will not be forwarded to the national committee by this region)</i> </p>
<p>Comments and justification for the regional recommendation to NCWM: <i>(This will appear in NCWM reports)</i></p> <p>The following comments were received during the 2022 SWMA Annual Meeting:</p> <p>Mr. Keilty, Endress+Hauser, stated that Block 7 is dependent on Block 8, and both blocks should receive the same status. He had no recommendation on it. This is an example where meters are being added into three codes.</p> <p>The SWMA S&T Committee recommends this item remain as a Developing Item.</p>

3

4 **BLOCK 8 ITEMS (B8) TOLERANCES ON TESTS USING TRANSFER STANDARDS,**
 5 **APPENDIX A - TOLERANCES FOR STADARDS, AND**
 6 **APPENDIX D – FIELD STANARDS AND TRANSFER**
 7 **STANDARDS**

8 *Note: These proposals are a combined modification of the 2021 S&T Agenda Block 1 Items GEN-19.1 and*
 9 *OTH-22.1. Since the S&T Committee has changed item GEN-19.1 from “assigned” to “developing,” the*
 10 *submitter has worked with NIST OWM to revise and combine the original proposals of GEN-19.1 and OTH-*
 11 *22.1 to address discussions within the NCWM Field Standards Task Group and other comments received*
 12 *at the regional weights and measures meetings on the proposals. These items are related, so they are*
 13 *presented together. These OWM and Seraphin proposals were submitted to the S&T Committee just before*
 14 *the 2022 Interim Meeting.*

15 *Note: The OWM and Seraphin proposals submitted to the S&T Committee just before the 2022 Interim*
 16 *Meeting were updated with two changes at the request of the Submitters following the 2022 Interim*
 17 *Meeting. The first change is in the definition of “Standard, Field.” The words “(typically one year)” were*
 18 *replaced with “(as determined by the Director)”.* The second change was to add the words “to the
 19 *International System of Units (SI)” in the section 3.1.3. of the Fundamental Considerations. These two*
 20 *changes are reflected in the items below.*

21 **Source:**

22 Seraphin Test Measure Company (GEN-19.1) and NIST, Office of Weights and Measures (OTH-22.1)

1 **Purpose:**

- 2 (a) Add a tolerance statement to the General Code that applies whenever a Type 2 transfer standard is used;
- 3 (b) Clarify in the Fundamental Considerations (Appendix A of Handbook 44) that the authority to approve field
4 test standards rests with the regulatory official and that specific types of field test standards need not be
5 identified in the body of a Handbook 44 Code in order to be approved by the weights and measures director;
- 6 (c) Add text to Section 3.2. Tolerances for Standards of the Fundamental Considerations (Appendix A of
7 Handbook 44) to recognize the wide range of transfer standards already recognized in Handbook 44, explain
8 the critical differences between field standards and transfer standards, and to specify the formula to be used
9 to calculate the device tolerance when the uncertainty of the transfer standard exceeds the one-third
10 requirement; and
- 11 (d) Add definitions to Appendix D of Handbook 44 for field standard and Type 1 and Type 2 transfer standards
12 that identify the critical characteristics for field and transfer standards.

13 **B8: GEN-19.1 D G-T.5. Tolerances on Tests When Transfer Standards are Used., Appendix**
14 **A, Section 3.2. Tolerances for Standards., and Appendix D – Definitions:**
15 **standards, field., ~~transfer standard.~~ and standard, transfer.**

16 **Item Under Consideration:**

17 Amend Handbook 44, General Code as follows:

18 **G-T.5. Tolerances on Tests When Type 2 Transfer Standards Are Used. – When Type 2 transfer**
19 **standards are used, the following formula shall be used to compute the tolerance applicable to the**
20 **device under test:**

21 **Increased MPE = (2/3 x MPE + U)**

22 **with an upper limit of $U_{MAX} = 2/3 MPE$**

23 **Where MPE is the basic tolerance that applies when using a basic reference standard; and**

24 **U = uncertainty associated with the Type 2 transfer standard.**

25 **The increase in the applied tolerance when using a Type 2 transfer standard applies only to the basic**
26 **tolerances for devices as defined in Handbook 44; that is acceptance, maintenance and minimum**
27 **tolerances. Note that the repeatability tolerance and the special test tolerances are NOT increased.**

28 **Codes 5.56.(a) Grain Moisture Meters, 5.56.(b) Grain Moisture Meters, and 5.57. Near-Infrared Grain**
29 **Analyzers are exempt from this requirement because NIST Handbook 159 has requirements for**
30 **monitoring and retesting grain samples to ensure adequate stability and the tolerances for the devices**
31 **under test already incorporate the uncertainty associated with the use of grain samples as transfer**
32 **standards. The code 2.21. Belt-Conveyor Scale Systems Code is also exempt because relative and**
33 **absolute tolerances are included in the code.**

34 Amend Handbook 44 Appendix D – Definitions as follows.

35 **Standard, Field. – A physical artifact, static or dynamic measurement device or a reference material**
36 **that (a) meets the requirements of the Fundamental Considerations, Section 3.2., (b) is stable (accurate**
37 **and repeatable) over an extended period of time (as determined by the Director), (c) is valid**
38 **(corrections that may be used) over the range of environmental and operational parameters in which**
39 **the commercial measuring devices are used, and (d) is traceable to the reference or working standards**
40 **through comparisons, using acceptable laboratory procedures. [3.34, 3.38, 3.39, x.xx, x.xx...]**

1 (Added 202X)

2 ~~transfer standard.—A measurement system designed for use in proving and testing cryogenic liquid-~~
 3 ~~measuring devices. [3.38]~~

4 Standard, Transfer, Type 1 and Type 2. – A physical artifact, static or dynamic measurement device
 5 or a reference material that is proven to be stable (accurate and repeatable) for a short time under the
 6 limited environmental and operational conditions during which the transfer standard is used. A Type
 7 1 transfer standard is a transfer standard that meets the one-third accuracy requirement for a short
 8 time over a limited range of environmental conditions and/or a limited range of operating conditions
 9 in which it is used. A Type 2 transfer standard is one that does not meet the one-third requirement and
 10 may not be stable or valid over an extended time period or over wide ranges of environmental or
 11 operating conditions. (3.34, 3.38, 3.39, x.xx, x.xx...]

12 (Added 202X)

13 **B8: OTH-22.1 D Appendix A: Fundamental Considerations, 3. Testing Apparatus**

14 **Item Under Consideration:**

15 Amend Handbook 44, Appendix A: Fundamental Considerations as shown below. Delete Footnote 2 referenced in
 16 Section 3. Testing Apparatus of NIST Handbook 44 Appendix A, Fundamental Considerations, moving portions of
 17 the footnote into Section 3.1 as part of the proposed changes to Section 3.1 shown above. Note that no changes are
 18 proposed to Footnote 1.

19 ~~²Recommendations regarding the specifications and tolerances for suitable field standards may be~~
 20 ~~obtained from the Office of Weights and Measures of the National Institute of Standards and Technology.~~
 21 ~~Standards will meet the specifications of the National Institute of Standards and Technology Handbook~~
 22 ~~105-Series standards (or other suitable and designated standards). This section shall not preclude the use~~
 23 ~~of additional field standards and/or equipment, as approved by the Director, for uniform evaluation of~~
 24 ~~device performance.~~

25 **3.1. Adequacy.**² – Tests can be made properly only if, among other things, adequate testing apparatus is available.
 26 Testing apparatus may be considered adequate only when it is properly designed for its intended use, when it is
 27 so constructed that it will retain its characteristics for a reasonable period under conditions of normal use, when
 28 it is available in denominations appropriate for a proper determination of the value or performance of the
 29 commercial equipment under test, and when it is accurately calibrated.

30 **3.1.1. Essential Elements of Traceability. To ensure that field test standards and test methods**
 31 **provide for measurements that are traceable to the International System of Units (SI), through NIST**
 32 **or other National Metrology Institutes, they must satisfy the “Essential Elements of Traceability.” As**
 33 **explained in NIST IR6969 GMP-13 Good Measurement Practice for Ensuring Metrological**
 34 **Traceability, these elements include the following.**

- 35 • Realization of SI Units
- 36 • Unbroken Chain of Comparisons
- 37 • Documented Calibration Program
- 38 • Documented Measurement Uncertainty
- 39 • Documented Measurement Procedure
- 40 • Accredited Technical Competence
- 41 • Measurement Assurance

42 **3.1.2. Specifications for Standards. Standards will meet the specifications of the National Institute**
 43 **of Standards and Technology Handbook 105-Series standards or other appropriate designated**
 44 **documentary standards (e.g., ASTM, ASME, etc.). Recommendations regarding the specifications and**
 45 **tolerances for suitable field standards may be obtained from the Office of Weights and Measures of**
 46 **the National Institute of Standards and Technology.**

1 **3.1.3. Authority for Approving Field Test Standards and/or Equipment. This section shall not**
2 **preclude the use of additional field standards and/or equipment, as approved by the Director, for**
3 **uniform evaluation of device performance. Specific types of field test standards are not required to be**
4 **identified in a NIST Handbook 44 code in order to be considered suitable. Provided the standards**
5 **meet the “Essential Elements of Traceability” (described in Section 3.1.1. above) that help ensure the**
6 **standards are suitable and capable of supporting measurements traceable to the International System**
7 **of Units (SI) through NIST or other National Metrology Institutes, they need only be approved by the**
8 **Director.**

9 **3.2. Tolerances for Standards.** – Except for work of relatively high precision, it is recommended that the
10 accuracy of **field** standards used in testing commercial weighing and measuring equipment be established and
11 maintained so that the use of corrections is not necessary. When the **field** standard is used without correction, its
12 combined error and uncertainty must be less than one-third of the applicable device tolerance.

13 Device testing is complicated to some degree when corrections to standards are applied. When using a correction
14 for a standard, the uncertainty associated with the corrected value must be less than one-third of the applicable
15 device tolerance. The reason for this requirement is to give the device being tested as nearly as practicable the
16 full benefit of its own tolerance.

17 **Whenever possible and practical, field standards should be used to test commercial devices. However,**
18 **where it is impractical or unduly cumbersome to use field standards, transfer standards may be used.**
19 **There are two categories of transfer standards. The critical criteria that distinguish between these**
20 **standards are: (1) the accuracy and uncertainty of the standard; (2) the stability as a standard over an**
21 **extended period; and (3) proven validity or performance of the standard over the range of environmental**
22 **and operational conditions in which the standard may be used.**

23 **A “field standard” is one that meets the one-third requirement mentioned earlier in this section.**
24 **Additionally, the field standard maintains its validity or stability as a standard over an extended period**
25 **(defined based on data of the standard’s stability by an authorized metrology lab or as specified by the**
26 **Director) and is known to maintain its value as a standard over the full range of environmental conditions**
27 **and the range of operating conditions in which the standard may be used to test commercial weighing and**
28 **measuring devices. Corrections, as documented by an authorized metrology laboratory, may be used.**

29 **Transfer standards do not meet one or more of these critical criteria. One category of transfer standards,**
30 **which is referred to here as a “Type 1 transfer standard,” is a transfer standard that meets the one-third**
31 **accuracy requirement for a short time, under a limited range of environmental conditions and/or a limited**
32 **range of operating conditions. The accuracy of a Type 1 transfer standard may have to be verified through**
33 **testing each time it is used to verify that the desired accuracy and performance can be achieved when the**
34 **Type 1 transfer standard is used under the limited environmental and operating conditions. When a Type**
35 **1 transfer standard is used, the basic tolerances specified for the commercial measuring devices are applied**
36 **as specified in the applicable codes.**

37 **The second category of transfer standard, which is referred to here as a “Type 2 transfer standard,” is one**
38 **that does not meet the one-third requirement. The Type 2 transfer standard must be stable and valid under**
39 **the environmental or operating conditions in which it is used. The performance characteristics must be**
40 **confirmed with sufficient data to properly characterize the uncertainty associated with the Type 2 transfer**
41 **standard. When a Type 2 transfer standard is used, the tolerances applicable to the commercial weighing**
42 **and measuring device must be increased to recognize the large uncertainty or corrections associated with**
43 **the Type 2 transfer standard. When commercial meters are tested using a Type 2 transfer standard, the**
44 **tolerance applied to the meter under test shall be determined as specified in the General Code.**

45 **(Added 202X)**

46 **3.3. Accuracy of Field Standards.** – Prior to the official use of testing apparatus, its accuracy should invariably
47 be verified. Field standards should be calibrated as often as circumstances require. By their nature, metal
48 volumetric field standards are more susceptible to damage in handling than are standards of some other types. A

1 field standard should be calibrated whenever damage is known or suspected to have occurred or significant repairs
 2 have been made. In addition, field standards, particularly volumetric standards, should be calibrated with
 3 sufficient frequency to affirm their continued accuracy, so that the official may always be in an unassailable
 4 position with respect to the accuracy of his testing apparatus. Secondary field standards, such as special fabric
 5 testing tapes, should be verified much more frequently than such basic standards as steel tapes or volumetric
 6 provers to demonstrate their constancy of value or performance.

7 Accurate and dependable results cannot be obtained with faulty or inadequate field standards. If either the service
 8 person or official is poorly equipped, their results cannot be expected to check consistently. Disagreements can
 9 be avoided and the servicing of commercial equipment can be expedited and improved if service persons and
 10 officials give equal attention to the adequacy and maintenance of their testing apparatus.

11 **Previous Action:**

12 2022: Developing

13 **Background and Discussion:**

14 NCWM 2022 Interim Meeting: Item GEN-19.1 was assigned to the original submitter, Seraphin, for further
 15 development. As noted at the beginning of this item Seraphin has worked with NIST OWM to revise and combine
 16 the original proposals of GEN-19.1 and OTH-22.1. Consequently, NIST OWM has asked that OTH-22.1 be combined
 17 with GEN-19.1. For more information or to provide comment, please contact:

18 Mr. Robert Murnane
 19 Seraphin Test Measure Company
 20 A Division of Pemberton Fabricators, Inc.
 21 609-267-0922, rmurnane@pemfb.com
 22 or

23 Ms. G. Diane Lee
 24 NIST Office of Weights and Measures
 25 diane.lee@nist.gov

26 2022 NCWM Annual Meeting: The committee heard from Tina Butcher NIST, the submitter of the item. She stated
 27 that they had addressed items heard at the fall regional meeting and the 2022 interim NCWM meeting. She stated they
 28 felt the item as is ready to move forward in tandem with Block 7. The intent is to clarify that it isn't necessary to
 29 identify what type of standard is to be used, i.e.: provers aren't referenced in section 3.30. OWM also provided written
 30 comments on this item.

31 The submitter of the original GEN 19.1 provided the following:

32 Over the last several years, there have been, and still are, proposals to recognize some types of meters as either transfer
 33 standards or as field standards. Handbook 44 already recognizes the use of many different types of master meters,
 34 other reference materials, or devices as transfer standards. This proposal is based upon the existing recognition and
 35 permitted use of transfer standards that are already in Handbook 44.

36 However, there is no common understanding among industry and weights and measures officials as to what
 37 distinguishes a field standard from a transfer standard. Consequently, changes are proposed to the Fundamental
 38 Considerations Section 3.2. and definitions are proposed for field standards and transfer standards to highlight the
 39 critical differences between these two types of standards. Any artifact, reference material or measuring device that
 40 meets the requirements of accuracy and repeatability as specified in Section 3.2. of the Handbook 44 Fundamental
 41 Considerations qualifies as a field standard. However, what has not been clearly understood is that **the field standard**
 42 **must meet Section 3.2. over the environmental and operational parameters in which the commercial measuring**
 43 **devices under test are used.** The ranges for these environmental and operational parameters may be very large and
 44 include:

- 1 • The range of flow rates at which the commercial meters under test operate (from the minimum to maximum
- 2 flow rates for the meters);
- 3 • The range of air temperatures over which meters are used (perhaps 10° F to 105° F);
- 4 • The range of product temperatures over which meters are used (perhaps 10° F to 105° F, especially applicable
- 5 for above ground storage tanks);
- 6 • The range of temperature differences that may exist between the product, the standard and the air over which
- 7 meters are used (perhaps up to 50° F, especially for cold fuel in underground tanks and hot air temperatures);
- 8 • The range of pressures at which the pumping systems operate at different times and locations;
- 9 • The different products measured by similar meters; and
- 10 • Tests of multiple “standards” of the same type when used in different test system configurations (and
- 11 “standards” of different sizes) to verify that the results agree and are consistent.

12 A range of environmental and operational parameters over which a transfer standard must meet the accuracy and
13 repeatability requirements are more limited, that is, a transfer standard need only be accurate and repeatable over the
14 conditions that exist for the “short” time that the transfer standard is used. Transfer standards may be tested before
15 and after use to verify a commercial measuring device, so the range of conditions in which accuracy and repeatability
16 may be relatively small. The transfer standard is only required to be accurate and repeatable during the time it is in
17 use, which might be to test only one commercial device. For example:

- 18 • The range of flow rates at which the meters under test operate **at the time of the test**;
- 19 • The range of air temperatures that exist **at the time of the test**;
- 20 • The range of product temperatures that exist **at the time of the test**;
- 21 • The range of temperature differences that may exist between the product, the standard and the air **at the time**
- 22 **of the test**;
- 23 • The range of pressures at which the pumping systems operate **at the time of the test**; and
- 24 • The product being measured by the meter **at the time of the test**.

25 A critical issue that has not be adequately addressed and defined is, “How long must a field standard remain valid
26 (i.e., accurate and repeatable)?” Common sense dictates that the field standard must remain valid over an extended
27 period of time. Transfer standards need only remain valid during their “short” period of use. Because (1) there are
28 some many different types of field standards used to test commercial measuring devices, (2) there are so many transfer
29 standards recognized in Handbook 44, and (3) the applications vary greatly, it isn’t clear that a common minimum
30 time period for field standards or for transfer standards can be established. Nevertheless, field standards must be valid
31 and stable over long time periods and wide ranges of environmental and operational parameters as compared to transfer
32 standards.

33 Additionally, transfer standards do not have to meet the one-third requirement for the uncertainty associated with its
34 performance. Consequently, Handbook 44 typically specifies that the basic tolerances to be applied to the device under
35 test be increased by two times the standard deviation of the transfer standard. This presumes that the transfer standard
36 has been adjusted to have “zero error” or corrections are used to address any significant systematic errors in the transfer
37 standard. This also applies when field standards are used. “The reason for this requirement is to give the device being
38 tested as nearly as practicable the full benefit of its own tolerance.”³

39 The submitter also provided the following possible opposing arguments:

- 40 I. There are several proposals before the S&T Committee to recognize some meters as field standards and field
- 41 standard reference meters. These proposals have not specified how the proposed field standards are to be tested
- 42 to demonstrate compliance with the Fundamental Considerations requirements of Section. 3.2. It is possible
- 43 that some companies will push for the recognition of meters as field standards without submitting data to
- 44 support their claims of performance as field standards.

³ Handbook 44, Fundamental Considerations, Section 3.2.

- 1 II. It is very difficult, time consuming and expensive to test meters that are proposed for use as field standards,
2 especially to test using different fuels over the range of temperatures that exist for commercial applications and
3 for temperature differences between the fuel and the air. It is possible that some will object to having to prove
4 meter performance over the range of environmental and operational parameters.

- 5 III. It is possible that some companies will want to use performance data collected under laboratory conditions as
6 being indicative of the expected performance of the meters under field conditions.

- 7 IV. Laboratory calibration procedures may not reflect the performance of the proposed field standard under field
8 conditions.

- 9 V. Some companies may object to the cost of collecting data for transfer standards (meters) of different sizes and
10 with different flow rate ranges to prove that the results for the different sized transfer standards (metering
11 systems) will produce consistent test results on the same commercial meters.

- 12 VI. Establishing a reasonably good estimate of the standard deviation associated with a transfer standard (to be
13 added to the basic tolerances for the devices under test) may require significant time, effort and cost.

- 14 VII. Some companies may want to modify the device under test to be able to test the commercial measuring device,
15 rather than testing the device as used.

16 The submitter states that these items are fully developed and requested that this be a Voting Item in 2022.

17 **Background and Discussion for Item OTH-22.1 originally submitted by NIST Office of Weights and Measures.**

18 **Source:**
19 NIST, Office of Weights and Measures

20 **Previous Action:**
21 New

22 **Original Justification:**

23 Footnote 2 of Handbook 44, Appendix A, Fundamental Considerations, Section 3. Testing Apparatus was added to:

- 24 (1) specify recommendations for suitable field test standards;
- 25 (2) require that field test standards meet specifications in Handbook 105 Series or other appropriate documentary
26 standards; and
- 27 (3) note that guidance may be obtained from NIST OWM regarding appropriate specifications, tolerances, and
28 other criteria for assessing the suitability of a field test standard for use in inspecting and testing commercial
29 weighing and measuring equipment.

30
31 Footnote 2 also recognizes that the Director has the authority to approve additional field test standards and/or
32 equipment beyond those recommended by NIST or specified in a Handbook 105 or other documentary standard. NIST
33 OWM periodically receives inquiries regarding the use of various types of test equipment and test methods. OWM
34 has worked with state weights and measures programs and industry to develop standards and procedures and
35 recommendations on the use of such equipment/methods and, in some cases this has resulted in a specific
36 recommendation or Handbook 105. However, as recognized, in Footnote 2, this does not preclude the Director from
37 approving equipment for which a specific Handbook 105 or other documentary standard does not exist.

38 In order to be considered suitable for use in official testing of a commercial weighing or measuring device, field test
39 standards and procedures need to meet a list of what is often referred to as the “Essential Elements of Traceability.”
40 This list includes elements outlined in NIST IR6969 GMP-13 Good Measurement Practice for Ensuring Metrological
41 Traceability shown above in the proposed Section 3.1.1. Essential Elements of Traceability. Provided steps are taken

1 to ensure that a given field test standard has been demonstrated to meet the requirements in these elements, it is
2 appropriate for that field test standard to be used in the official inspection and testing of a commercial weighing or
3 measuring device or for use by a service company in testing and placing a device back into service after service work.

4 While Footnote 2 already provides a statement regarding the authority of the Director to approve such equipment,
5 OWM believes including additional information regarding the essential elements of traceability and a reference to
6 specific measurement practices would be helpful to both emphasize that authority and provide guidance to Directors
7 and industry regarding the selection of appropriate field test standards.

8 NIST OWM recommends the guidance originally included in Footnote 2 along with the additional references to the
9 “Essential Elements” described above are best included in the body of Section 3 for clarity and ease of use.
10 Consequently, OWM recommends deleting the existing Footnote 2 and incorporating its contents into the body of
11 Section 3.

12 OWM also believes that some may erroneously believe that field test standards must be specifically listed within a
13 NIST Handbook 44 code in order to be used in the inspection and testing of devices covered by that code. Providing
14 a clear statement that this is not the case along with a reference to the required criteria may help alleviate this
15 misunderstanding.

16 The submitter acknowledges that Footnote 2 already provides a clear statement that the Director has authority to
17 approve standards which are not addressed by a NIST Handbook 105 Series handbook. Some might argue that the
18 proposed inclusion of additional information and guidance is not necessary.

19 The submitter states that these items are fully developed and requested that this be a Voting Item in 2022.

20 **Additional Justification for the Formula in the Proposed G-T.5.**

21 **Assessment of the 2/3 Formula and the OIML “Reduced MPE” Formula**

22 The 2/3 Formula: Increased MPE = $(2/3 \times \text{MPE} + U)$ with an upper limit of $U_{\text{MAX}} = 2/3 \text{ MPE}$

23 OIML Formula: Reduced MPE = $(4/3 \times \text{MPE} - U)$

24 *Note: The general term “standard” is used in this paper to address both field standards and transfer standards. The*
25 *specific terms “field standard” and “Type 2 transfer standard” (T2TS) distinguish between these two types of*
26 *standards according to the proposed definitions submitted to the NCWM by Seraphin. Type 1 transfer standards*
27 *(T1TS) are not addressed in this paper.*

28 Based on the results of a discussion between one of the submitters (Seraphin) and Marc Buttler, Emerson - Micro
29 Motion, the submitters agreed to recommend the 2/3 formula for use rather than the OIML formula. However, it is
30 essential that an upper limit be established on the uncertainty associated with a Type 2 transfer standard (abbreviated
31 as T2TS). The submitters agreed to recommend this upper limit not exceed 2/3 of the MPE of the commercial device
32 under test. The same limit should be used if the OIML formula is used.

33 The OIML formula and the 2/3 formula are similar, but they take different approaches to establish the tolerances for
34 the device under test. The 2/3 formula is more logical, more technically consistent with the Handbook 44 concept of
35 Type 2 transfer standards, and it is easier to understand. The 2/3 formula combines the tolerance that remains to be
36 used by the commercial device with the growing uncertainty of the T2TS into one total tolerance value, whereas the
37 OIML Reduced MPE calculates only the tolerance applied to test of the commercial meter under test. When Type 2
38 transfer standards are used in the field, the uncertainties associated with the T2TS should be recorded on the report
39 form or a copy of the calibration certificate should be left with the test report, so the uncertainty values are available
40 on site and can be used in an analysis should the tests with another T2TS generate different results.

41 The most accurate reference standard that is available should always be used for any field test. However, when the
42 only practical option for a field test that is available is a Type 2 transfer standard, the 2/3 formula will err in favor of

1 the commercial device to avoid failing a device that should have passed. Conversely, the OIML Reduced MPE might
 2 result in failing a commercial device that would have passed had a more accurate (e.g., Type 1 transfer or field)
 3 reference standard been available to use for the test.

4 **Conclusion**

5 Field standards are intended to have an error and uncertainty less than or equal to 1/3 of the tolerance applied to the
 6 commercial device under test. When a Type 2 transfer standard has an uncertainty slightly greater than 1/3 of the
 7 tolerance, then, using the 2/3 formula, the total tolerance applied to the device under test increases above the H44
 8 tolerance by the amount that the uncertainty associated with the Type 2 transfer standard exceeds the 1/3 limit, thereby
 9 establishing a total tolerance slightly greater than the H44 tolerances specified in the applicable codes and keeping the
 10 portion of the tolerance that remains allocated to the device under test at a constant level equal to 2/3 of the H44
 11 tolerance. When the uncertainty for the Type 2 transfer standard exceeds 1/3 of the MPE, the OIML formula resets
 12 the “Reduced MPE” (applied tolerance) to 100% of the MPE. As the uncertainty of the Type 2 transfer standard gets
 13 larger and larger, the tolerance allocated to the device under test (e.g., a meter since OIML R117 applies to meters)
 14 gets smaller and smaller, to the extent that it is not realistic to use a T2TS to test a commercial meter, because the
 15 uncertainty of the T2TS uses up most of the device tolerance. The 2/3 formula is consistent with (but actually smaller
 16 than) the usual H44 tolerances that state that the basic tolerances are to be increased by two standard deviations when
 17 using a T2TS. Note that with a U_{MAX} of 2/3 MPE for the maximum uncertainty of the T2TS, the applied tolerance
 18 associated with the field test result using the 2/3 formula never exceeds 1.33 of the original H44 tolerance for the
 19 device under test. The submitters note that, while these principles and associated formula were established to apply
 20 to metering systems, the concepts can apply equally to other types of commercial weighing and measuring equipment.

21 The 2/3 formula specifies the total uncertainty as the device tolerance when a T2TS is used. The OIML formula
 22 generates only the tolerance applied to the meter under test when a T2TS is used. The OIML formula is designed to
 23 keep the **combined** Reduced MPE value plus the uncertainty associated with the T2TS equal to 1.33 MPE. The OIML
 24 formula should also have an upper limit for the uncertainty of the T2TS as well, which should be U_{MAX} of 2/3 MPE.
 25 Note that when there is an upper limit of 2/3 the MPE, then the OIML formula always has a tolerance (applied MPE
 26 or the Reduced MPE) that is greater than or equal to 2/3 of the original MPE. The OIML Reduced MPE is the tolerance
 27 applied to the reading of the meter under test compared to the reading of the T2TS. Consequently, the use of the
 28 Reduced MPE with a T2TS is a meter-to-meter or device-to-device tolerance.

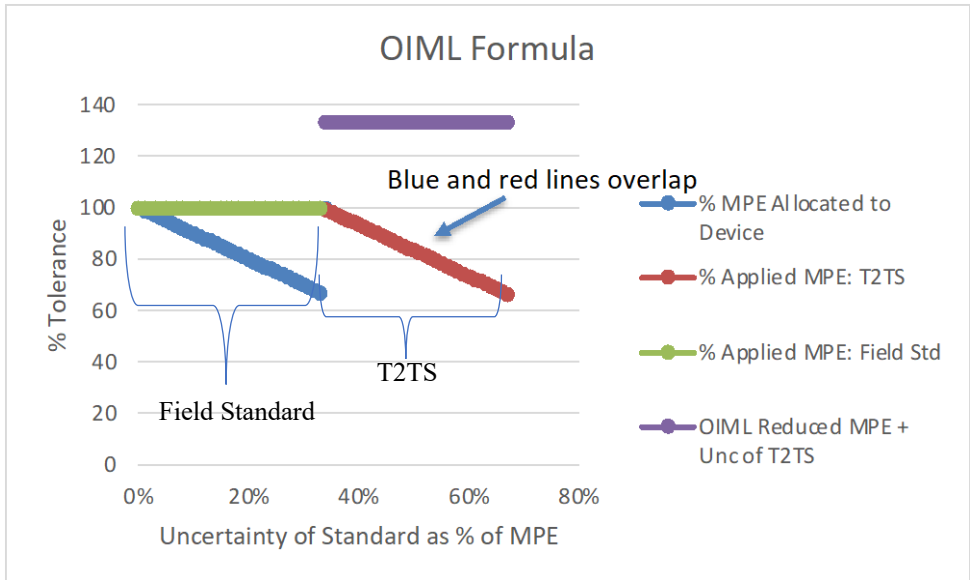

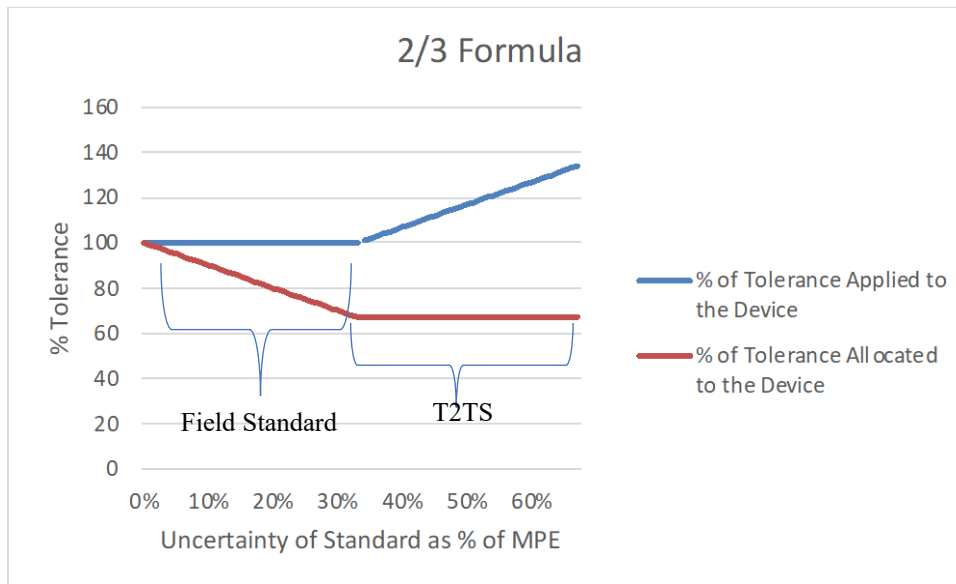

1
 2 The error in the device under test is determined as the difference between the indication of the device under test
 3 compared with the value represented or measured by the standard (usually presumed to have zero error or corrections
 4 are used for any errors in the standard).

5 The increase in the applied tolerance when using a Type 2 transfer standard applies only to the basic tolerances for
 6 devices as defined in Handbook 44, i.e., acceptance, maintenance and minimum tolerances.⁴ Note that the repeatability
 7 tolerance and the special test tolerances are NOT increased. [Note that the definition should apply to all codes, not
 8 just those listed with the definition, which do not include all codes that refer to basic tolerances.]

9 ***Explanation and Assessment***

10 ***Field Standards: Uncertainty is Part of the Tolerance***

11 Under the Fundamental Considerations, the correction and uncertainty of field standards are not to exceed 1/3 of the
 12 tolerance for the device under test. Under this condition, field standards are considered to be known values and the
 13 H44 tolerance is applied to the device under test without any consideration for the uncertainty associated with the field
 14 standard. The uncertainty associated with field standards may vary from nearly zero relative to the tolerance for the
 15 device under test up to 1/3 of the tolerance for the device under test. Even though the field standard may have an
 16 uncertainty as large as 1/3 of the tolerance applied to the device under test, the tolerance specified in H44 for the
 17 device is applied without consideration for the uncertainty associated with the field standard. The objective of this
 18 limit on the uncertainty associated with field standards "...is to give the device being tested as nearly as practicable
 19 the full benefit of its own tolerance."⁵ Once the uncertainty associated with a "standard" exceeds the 1/3 limit, the
 20 "standard" no longer qualifies as a field standard, but is a Type 2 transfer standard under Seraphin's proposed
 21 definitions.

⁴ **basic tolerances.** – Tolerances on underregistration and on overregistration, or in excess and in deficiency, that are established by a particular code for a particular device under all normal tests, whether maintenance or acceptance. Basic tolerances include minimum tolerance values when these are specified. Special tolerances, identified as such and pertaining to special tests, are not basic tolerances. [2.20, 2.22., 3.34, 3.38, 4.42, 5.54]

⁵ Handbook 44, Fundamental Considerations, Section 3.2

1 *Type 2 Transfer Standards: Uncertainty is Added to the Tolerance*

2 When the uncertainty associated with a T2TS exceeds 1/3 of the tolerance applied to the device under test, the
 3 uncertainty of the T2TS is recognized in the field test result by increasing the tolerance that is applied to the device
 4 under test. The OIML formula and the 2/3 formula take different approaches to increasing the tolerance for the device
 5 under test.

	Field Standard	Field Standard	OIML Formula	OIML Formula	2/3 Formula	2/3 Formula
Uncertainty of Standard (as % of Tolerance)	% of MPE (Tolerance) Applied to the Device	% MPE (Tolerance) Allocated to Device	% of MPE Applied to the Difference in the Test Results Using a T2TS	OIML Reduced MPE and Uncertainty of T2TS (%)	% of Combined Tolerance and Uncertainty Applied to the Device	% of Combined Tolerance and Uncertainty Allocated to the Device
0%	100	100				
10%	100	90				
20%	100	80				
30%	100	70				
33%	100	67				
34%			99	133	101	67
40%			93	133	107	67
50%			83	133	117	67
60%			73	133	127	67
67%			67	133	133	67
70%			63	133	137	67
80%			53	133	147	67
90%			43	133	157	67
100%			33	133	167	67

6
 7 The OIML formula increases the tolerance applied to the device under test by 1/3 minus the uncertainty of the T2TS
 8 as soon as the uncertainty of the Type 2 transfer standard exceeds the 1/3 limit. This increase recognizes the uncertainty
 9 that is up to 1/3 of the tolerance for field standards. Hence, the tolerance applied to the device under test plus the
 10 uncertainty of the T2TS is 1.33 times the original MPE when the uncertainty of the Type 2 transfer standard exceeds
 11 1/3 of the MPE. As the uncertainty of the Type 2 transfer standard increases, the portion of the MPE allocated to the
 12 meter under test for the field test result decreases. If the uncertainty of the Type 2 transfer standard becomes very
 13 large, the poor accuracy and/or poor repeatability of Type 2 transfer standard makes its use ineffective.

14 In the 2/3 approach, the formula starts with 2/3 of the device tolerance (i.e., the MPE) apportioned to the device under
 15 test, which is the situation when the uncertainty of a field standard is exactly equal to 1/3 of the device tolerance. Next,
 16 the uncertainty associated with the T2TS is added to the 2/3 of the original MPE. Consequently, the tolerance (i.e.,
 17 the MPE) applied to the field test gradually increases by the same amount as the uncertainty for the Type 2 transfer
 18 standard increases above the 1/3 level of the original MPE. An upper limit for the uncertainty of the T2TS is proposed
 19 to be 2/3 of the MPE, so that the uncertainty does not increase without limit and become meaningless. Hence, the
 20 tolerance applied to the device under test, when a T2TS has an uncertainty at the upper limit of 2/3 the MPE, the total
 21 tolerance plus the uncertainty will be 1.33 times the original MPE, which is equal to the maximum allowed by the
 22 OIML formula for the Reduced MPE plus the uncertainty of the T2TS when the uncertainty of the T2TS just exceeds
 23 the 1/3 limit.

1 *The Impact of Large Uncertainties for Field and Transfer Standards*

2 When different standards are used to test the same commercial devices, there is the possibility that the results will not
3 agree exactly. As the uncertainties associated with the field or Type 2 transfer standards increase, then the probability
4 increases that the field test results will not agree or even agree within tolerance. The concern is that some commercial
5 devices could be tested with one standard and pass (or fail) the field tests, but, when tested with a different standard,
6 some commercial devices would fail (or pass) the field tests. Consequently, it is important to keep the uncertainties
7 associated with the standards used to test commercial devices as small as reasonably possible, so that the probabilities
8 of getting different field test results when using different standards are reduced.

9 **Regional Associations' Comments on GEN-19.1:**

10 WWMA 2021 Annual Meeting: Marc Buttler (Emerson Micro Motion): Regards to the fine work of the workgroup
11 and authors of form 15, he finds it useful and helpful by augmenting the existing wording to add clarity as we work
12 forward to more practical testing. He wanted to comment on whether the underlying principle of affording additional
13 tolerance not capable of meeting the 1/3rd. In the language there is an equation (lower down in the proposal) reduced
14 MPE. This is intended to penalize the tolerance of the device and not give additional leeway. Further into the
15 justification it references an established principle that says that additional tolerance is afforded when complex. A
16 better equation would be to take the MPE x 2/3 PLUS and not minus. This avoids jurisdictions having different
17 uncertainty testing to different tolerances. He can prepare a written summary of his comments and will send to us.
18 Bob Murnane (Seraphin): Seraphin proposed this. There is a lack of definitions. This comes into play in block 5. This
19 was put in to clarify and give definite definitions to field and transfer standards. He hopes this clarifies multiple items
20 on the agenda. Russell Vires (Scale Manufacturers Association): This item has been around for a while and was part
21 of block 1. It has been pulled out and changed. The SMA has made comments in the past to support this item, but at
22 this point they will meet in November and review; they have not been able to review the substantial changes yet. They
23 have no position as of now. This needs to remain developing to allow stakeholders the opportunity to review.

24 Diane Lee (NIST OWM): Wants to expand on Russ's comments. This was included in a block with terminology for
25 standards, (master meter, transfer standard or field standard). She questioned whether the transfer standards could
26 meet the 1/3 standard. NIST has an analysis from the annual meeting that will address some of the issues; however,
27 they have not met as a group yet. We can look online on NCWM and look forward to them providing additional info.
28 (Previous analysis is available on the NCWM website).

29 The WWMA recommended that this be a Developing Item.

30 SWMA 2021 Annual Meeting: Mr. Henry Oppermann, representing Seraphin, explained the differences between
31 Field Standards, Type 1 and Type 2 Transfer Standards, and expressed support for a proposed change that originated
32 in the Western. Mr. Tim Chesser, State of Arkansas, questioned what "sufficient data" would be once a device is
33 placed into service as a Standard, and how often it would need to be reverified. Mr. Oppermann responded to Mr.
34 Chesser stating that the Master Meter Task Group must evaluate the performance of these devices and create
35 calibration and performance requirements in the future. Russ Vires, Scale Manufacturers Association, stated that they
36 have no position at this time. Russ Vires, Mettler Toledo, stated that he believes this is in conflict with Block 1, and
37 would recommend it continue with a Developing status. Mr. Michael Keilty, Endress + Hauser, assured Mr. Chesser
38 that any devices used as a Field Standard would have a traceable chain of metrology.

39
40 The SWMA recommended that this item remain Assigned pending the Workgroup finding a new Chairperson.

41 CWMA 2022 Annual Meeting: Bob Murnane – Seraphin - Transfer standard is already included in HB44 but it isn't
42 defined.

43 This doesn't preclude the ability for The Director to approve transfer standards.

44 HB44 doesn't specify the frequency of testing intervals; cast iron vs stainless steel weights as an example.

45 G.UR.4.1 already states the owner or operator must maintain the equipment, which includes the accuracy.

1 States have different interval requirements. Recommends moving to a voting item.

2

3 Jan Konijnenburg – NIST OWM - State and industry have a need to use various types of test standards to evaluate
4 commercial devices installed in the marketplace. NIST OWM recognizes the need to use various standards to test
5 commercial devices and support the use of these standards when test data supports its use.

6 Block 8 clarifies the use and definition of three types of standards to be included in NIST HB 44: (1) Fields Standards,
7 (2) Type 1 Transfer Standards and (3) Type 2 Transfer Standards; it provides an equation that should be used to
8 calculate the tolerances when Type 2 transfer standards are used; provides definitions for Field Standards, Type 1
9 Transfer Standards and Type 2 Transfer Standards, and provides clarification that the State Director has the authority
10 to approve the use of standard and that specific requirements in NIST HB 44 code are not necessary to approve a
11 standard for use.

12 Two items, LPG-15.1 and MFM-15.1 in the Interim Meeting Report (Publication 16), include a purpose statement
13 that the proposals are added to allow field standard meters to be used to test and place into service dispensers and
14 delivery system flow meters. Block 8 items clarify what has always been recognized in NIST HB 44 concerning the
15 responsibility for acceptance of a standard and notes that specific code changes are not necessary for a field standard
16 to be adequate for use.

17 In addition to the changes in Block 8, a new form 15 for the 2023 cycle which is not included in the 2022 Publication
18 16 and has not been addressed separately in the 2022 NIST OWM Technical Analysis but has been circulated to the
19 Spring 2022 Regional Associations (NEWMA and CWMA)

20 This new Form 15 adds a General Code requirement so that rather than revising a specific code in Handbook 44 every
21 time a new field or transfer standard is proposed or developed, an overall statement in the General Code recognizes
22 the use of other field and transfer standards that meet the requirements for use as field or transfer standards. The
23 proposal is as follows:

24 G-N.3. Test Methods. – Permissible test methods for verifying compliance of weighing and measuring systems with
25 the provisions of the General Code and Specific Codes include, but are not limited to, test methods and apparatus that
26 have been approved by the State Director of weights and measures as outlined in Appendix A - Fundamental
27 Considerations, Section 3. Testing Apparatus.

28 NIST OWM also observed that the definitions in Block 8 should include appropriate references to the NIST HB 44
29 codes.

30 OWM Recommendation: The submitters agree that these items, GEN-19.1 and OTH-22.1 are fully developed and
31 requested that this S&T committee consider that Block 8 item be a Voting Item in 2023.

32
33 Charlie Stutesman – KS – GEN-19.1 line 29 – strike “as determined by the Director”
34 “short term” and “extended term” are ambiguous phrases.

35
36 Loren Minich – KS – Page 277 line 41 regarding a Type 2 transfer standard not being stable or valid over extended
37 time, but OTH-22.1 page 279 line 28 says the Type 2 standard must be stable and valid. Mr. Minich would like to
38 keep as developing.

39
40 Doug Musick – KS - Page 277 definitions: having the 1/3 rule in the code (and not in an appendix) is helpful. Suggested
41 that Type 2 should go away and just have a single “transfer standard” definition.

42 Michael Keilty – Endress+Hauser – “Short term”, “extended period of time”, “short period of time”, “stable”, “valid”
43 are arbitrary; who defines this? Who is going to establish this time period and qualifications of devices? Are we

1 establishing a program for that? API chapter 4.8 dictates 5 year calibration intervals for small volume provers, for
2 example.
3 Additional letters, presentation and data may have been submitted for consideration with this item. Please refer to
4 <https://www.ncwm.com/publication-15> to review these documents.

5 The CWMA S&T Committee recommends this moves forward as a voting item.

6 NEWMA 2021 Interim Meeting: Mr. Bob Murnane (Seraphin) commented that the purpose of this proposal was to
7 define Type 1 and Type 2 Transfer Standards. Originally the proposal had the OIML formula, but the formula only
8 calculates the meter-to-meter tolerance and as the uncertainty associated with the transfer standard increases, the
9 tolerance allocated to the commercial device gradually decreases. The submitter is now proposing a “2/3 Formula”
10 where the calculation includes all the uncertainty associated with the transfer standard and the tolerance allocated to
11 the commercial meter never drops below 2/3 of the normal tolerance. Mr. Murnane requested that this proposal be
12 given a voting status.

13
14 After hearing comments from the floor, the committee recognized the need to further develop this block and
15 recommended the block retain developing status.

16 Additional letters, presentation and data may have been submitted for consideration with this item. Please refer to
17 www.ncwm.com/publication-15 to review these documents.

ITEM BLOCK 8

Regional recommendation to NCWM on item status:

- Recommend as a Voting Item on the NCWM agenda
- Recommend as an Information Item on the NCWM agenda
- Recommend as an Assigned Item on the NCWM agenda
(To be developed by an NCWM Task Group or Subcommittee)
- Recommend as a Developing Item on the NCWM agenda
(To be developed by source of the proposal)
- Recommend Withdrawal of the Item from the NCWM agenda
(In the case of new proposals, do not forward this item to NCWM)
- No recommendation from the region to NCWM
(If this is a new proposal, it will not be forwarded to the national committee by this region)

Comments and justification for the regional recommendation to NCWM: (This will appear in NCWM reports)

The following comments were received during the 2022 SWMA Annual Meeting:

Mr. Murnane, Seraphin, stated that you can't always define every environmental issue, and we must be able to use judgment.

Mr. Keilty, Endress+Hauser, stated that Block 8 adds a definition for Type 1 and 2 Transfer Standards into the code, and he recommends this item move forward as developing.

The SWMA S&T Committee questioned why the submitter wants to move some of these items into code when they have been traditionally covered by the Fundamental Considerations. Additionally, the Committee questioned the open-ended nature of the timeframe component in defining the type of standard, and section 3.1.1. Essential Elements of Traceability potentially restricting the Directors authority in allowing certain standards to be used. The committee also requests documentation of specific standards in use and which type of standard they would be based on these definitions.

The SWMA S&T Committee recommends this item move forward as a Developing Item.

Mr. Mike Lovisa, Louisiana | Chair
Mr. Timothy Morales, Texas | Member
Mr. Heath Higdon, Kentucky | Member
Mr. Greg Gholston, Mississippi | Member
Mr. Alan Walker, Florida | Member

SWMA Specifications and Tolerances Committee

Appendix A

Item Block 2 – Final Report of the Verification Scale Division Task Group

Participants:

Doug Musick, Chair (KS)
Ross Andersen (NY, Retired and original submitter of the item)
John Barton (NIST OWM)
Luciano Burtini (Measurement Canada)
Anthony Bong Lee (Orange County, CA)
Steve Cook (CA, Retired)
Darrell Flocken (NTEP)
Eric Golden (Cardinal Scale)
Jan Konijnenburg (Rice Lake Weighing Systems)
Richard Suiter (Richard Suiter Consulting)
Steve Timar (NY)
Howard Tucker (FL)

The mission of the task group, as defined by the S&T Committee, is to review Handbook 44, Section 2.20. Scales and relevant portions of OIML R76, using the items included in S&T Agenda Items: Block 2 as a reference point, and recommend changes as necessary to:

1. Clarify how the error is determined in relation to the verification scale division (e) and the scale division (d)
2. Clarify which is the proper reference; the verification scale division (e) or the scale division (d) throughout this section
3. Ensure proper selection of a scale in reference to the verification scale division (e) and the scale division (d)
4. Clarify the relationship between the verification scale division (e) or the scale division (d)

This report is divided into three sections:

1. Clarify the relationship between e and d, i.e., ensure we understand the terms. (Mission items 4 and 1)
2. Propose changes to the Scales Code, if necessary, to ensure the code correctly identifies e or d as appropriate to the code paragraph. (Mission items 2 and 3)
3. Address other issues that arose as potential problems that might require additional investigation beyond the scope of this workgroup.

PART 1. Clarify the Relationship Between e and d.

We begin by looking at current HB44 definitions. The verification scale division e is used to express tolerance values and it is used in classification. The designations of e and the accuracy class are made by the manufacturer. The scale division d is a function of the actual scale function and display. Note that for weight classifiers, the weighing instrument may never display quantity at the resolution of e, and for ungraduated devices there is no scale division d to permit comparison to e.

verification scale division, value of (e). – A value, expressed in units of weight (mass) and specified by the manufacturer of a device, by which the tolerance values and the accuracy class applicable to the device are determined. The verification scale division is applied to all scales, in particular to ungraduated devices since they have no graduations. The verification scale division (e) may be different from the displayed scale division (d) for certain other devices used for weight classifying or weighing in pre-determined amounts, and certain other Class I and II scales.[2.20]

scale division, value of (d). – The value of the scale division, expressed in units of mass, is the smallest subdivision of the scale for analog indication or the difference between two consecutively indicated or printed values for digital indication or printing. (Also see “verification scale division.”) [2.20, 2.22]

scale division, number of (n). – Quotient of the capacity divided by the value of the verification scale division. [2.20]

$$n = \frac{\text{Capacity}}{e}$$

The values of e and d must be understood as referring to different things. The verification scale refers to the scale of measurement for the reference (or true value), think of the reference standard. The instrument scale refers to the scale of measurement of the instrument under test. Consider this assortment of instruments in the table below. It should be clear that the divisions of the verification scale do not always equal those on the instrument scale and may not even be in the same units. In addition, when we employ an artifact, like a test weight or slicker plate measure, the divisions of the verification scale are not visible since the artifact represents a single point on the measurement scale of the reference.

Instrument Scale	Scale div d	Verification “True Value” Scale	Scale div e	Relation e to d
Rule	1/16 in	Standard Rule or Tape	1/16 in	e = d
Taximeter	1/10 mi	Road Course	2 ft	e << d
LMD’s	0.1 gal	Prover indication	5 cu in	e > d
Mass Flow Meter	1 lb	Reference Scale	0.01 lb	e < d
Weighing Devices	0.01 lb	Test Weight (artifact)	mfr choice	e < d, e = d, e > d
Test Measure	1 cu in	Slicker Plate (artifact)	?	e ? d

For weighing instruments, it turns out that e and d have no fixed relationship. It is different for weight classifiers (e < d), for most instruments (e = d), and for high resolution instruments (e > d). The critical point is that the instrument scale and the verification scale are independent of each other. Once you have disconnected e (declared by the manufacturer) from d (displayed on the instrument), it may now become evident that much of our confusion arose because we thought of them as connected in some way.

In the graphics below both error and tolerance are always expressed in terms of the divisions (e) of the verification scale. The primary assumption is that the verification scale is constant, and it is the displayed scales of the instruments we test that move. The scales in black are depicted as in error by +1 e or -1 e.

Error of delivery =
 verification scale – instrument scale
 + in excess
 – in deficiency

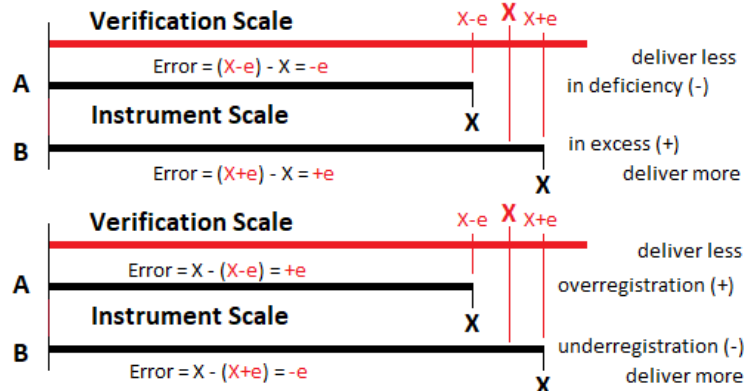

Error of Indication =
 instrument scale – verification scale
 + over registration
 – underregistration

Much of our confusion arises because scales are tested using artifacts with no visible scale divisions. We could mirror this in the test of a fuel dispenser. Normally you stop the test at 5 gallons on the instrument scale and read the error as -3 cu in from the test measure (verification) scale. Now change that procedure and stop the test at the zero mark on the test measure. How would you determine the error? Assume the instrument now reads 5.012 gal. The error is -0.012 gal (-3 cu in), and we calculate it as verification scale – instrument scale. We determined the error from the instrument scale. The verification scale division, however, did not switch from the test measure to the instrument simply because we changed the procedure. The verification scale division remains 1 cu in and is still on the test measure, the reference.

Consider the Class III scale at right where $e = d$. Technically you can't see divisions on either scale since the artifact has no visible divisions and the instrument is digital. The correct instrument indication of 500 d is 1.2 e short of 500 e on the verification scale. You could mirror this by applying 498.8 e of test weights to get indication of 500 d. It is not in tolerance, but only if you apply error weights in your test.

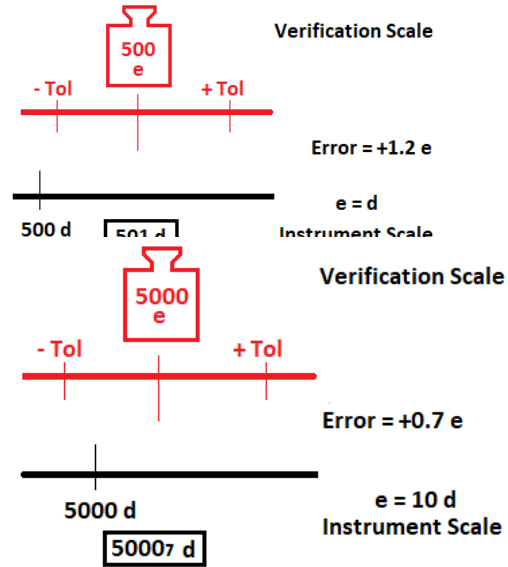

Consider the Class II scale at right where $e = 10 d$. You can't see divisions on either scale because the test weight is an artifact and the instrument are digital. The correct instrument indication of 50,000 d is short of the 5,000 e on the verification scale by 7 d. Thus, we say the error is +0.7 e. Error = instrument scale – verification scale. This instrument is clearly in tolerance. No error weights are necessary to see to finer than 1 e.

The principles of classification are found in the following HB44 paragraphs. In principle, the manufacturer tells the official what accuracy is to be applied to the instrument.

T.N.1. Principles.

T.N.1.1. Design. – The tolerance for a weighing device is a performance requirement independent of the design principle used.

T.N.1.2. Accuracy Classes. – Weighing devices are divided into accuracy classes according to the number of scale divisions (n) and the value of the scale division (d).

T.N.1.3. Scale Division. – The tolerance for a weighing device is related to the value of the scale division (d) or the value of the verification scale division (e) and is generally expressed in terms of d or e.

Yet, the T.N.1.2. and T.N.1.3. paragraphs conflict with the definitions. According to the definition of e, it is e “by which the tolerance values and the accuracy class applicable to the device are determined.” When the Scales Code was drafted prior to adoption in 1984, it appears some things were lost in translation from the OIML R76 on which it was based. What was lost can be expressed as those things not included in HB44 and those things incorrectly translated in HB44.

For example, R76 expresses the classification information in four required markings, and one auxiliary marking. R76 requires marking of Class, Max, e, and Min, and requires marking of d if different from e. Those markings describe the maximum and minimum loads and the relative accuracy. In contrast, HB44 requires marking of Class, capacity, and d, and requires marking of e if different from d. HB44 does not require marking of minimum load. While R76 considers minimum load part of the class structure, HB44 does not.

It is this switch of e and d that causes confusion because the translation of R76 to HB44 lost some of the meaning. Much of the second part of this report covers the changes required to rectify the situation. The workgroup is attempting to ensure the Code states e when the requirement applies to e and d when it applies to d. The workgroup is also proposing to add important material from R76 that is missing.

Some additional confusion comes from the stepped tolerance structure. For example, it is common to think that the instrument gets 1 division of error over the first tolerance step (maintenance). The correct interpretation of the code requires the instrument maintain a % accuracy based on the number of divisions of load at the break points. The space under the step riser is not supposed to be used by the instrument provided you eliminate the rounding error.

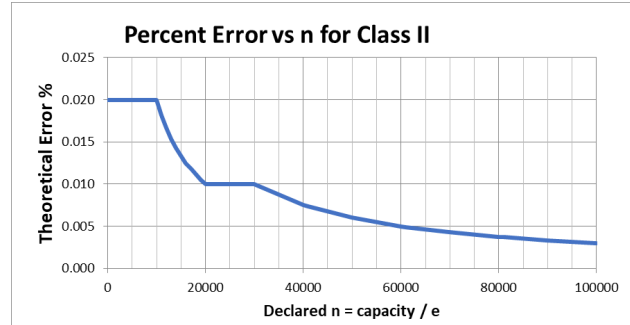

Between 1 division and 10,000 divisions for Class II in R76, this is 0.02%. At 10,000 e, 0.02% is 2 e. At 1,000 e, 0.02% is 0.2 e, and at minimum load of 50 e, 0.02% is 0.01 e. The principle is: the larger the number of verification scale divisions (n) the more accurate the instrument must be, i.e. relative error. Section 2.2 of R76 makes this clear by stating that e represents absolute accuracy and n represents relative accuracy. The Scales Code has no parallel section. It is the relative accuracy that should be our focus, but that's not found in HB44.

PART 2. Proposed changes to the Scales Code (related issues are grouped for convenience)

Group 1. Changes to clarify definitions relating to e.

verification scale division, value of (e). – A value, expressed in units of weight (mass) and specified by the manufacturer of a device, by which the tolerance values and the accuracy class applicable to the device are determined. The verification scale division is applied to all scales, in particular to ungraduated devices since they have no graduations. ~~The verification scale division (e) may be different from the displayed scale division (d) for certain other devices used for weight classifying or weighing in pre-determined amounts, and certain other Class I and II scales.~~[2.20]

(Amended 20XX)

The last sentence is explained fully in the technical requirements in the Code. The workgroup finds it unnecessary and believe it contributes to confusion.

verification scale division, number of (n). – Quotient of the capacity divided by the value of the verification scale division. [2.20]

$$n = \frac{Capacity}{e}$$

(Amended 20XX)

scale division, number of (n). – See “verification scale division, number of (n)”

The addition of the word “verification” to the definition of n is essential since without it the section refers to the scale division d. The second definition for n was added as a cross reference since the revision will move from the s section to the v section.

Group 2. Changes to ensure proper classification of instruments.

T.N.1.2. Accuracy Classes. – Weighing devices are divided into accuracy classes according to the number of verification scale divisions (n) and the value of the verification scale division (~~d~~) (e).

(Amended 20XX)

T.N.1.3. Verification Scale Division. – The tolerance for a weighing device is ~~related to the value of the scale division (d) or the value of the~~ in the order of magnitude of the verification scale division (e) and is generally expressed in terms of ~~d or e~~.

(Amended 20XX)

These changes bring the principles in the T.N. section in agreement with the definitions. Classification is exclusively based on e.

Table 3. <i>Parameters for Accuracy Classes</i>			
<i>Class</i>	<i>Value of the Verification Scale Division (d or e¹)</i>	<i>Number of Verification Scale⁴ Divisions (n)</i>	
		<i>Minimum</i>	<i>Maximum</i>
<i>SI Units</i>			
<i>I</i>	<i>equal to or greater than 1 mg</i>	<i>50 000</i>	<i>--</i>
<i>II</i>	<i>1 to 50 mg, inclusive</i>	<i>100</i>	<i>100 000</i>
	<i>equal to or greater than 100 mg</i>	<i>5 000</i>	<i>100 000</i>
<i>III^{2,5}</i>	<i>0.1 to 2 g, inclusive</i>	<i>100</i>	<i>10 000</i>
	<i>equal to or greater than 5 g</i>	<i>500</i>	<i>10 000</i>
<i>III L³</i>	<i>equal to or greater than 2 kg</i>	<i>2 000</i>	<i>10 000</i>
<i>IIII</i>	<i>equal to or greater than 5 g</i>	<i>100</i>	<i>1 200</i>

¹ For Class I and II devices equipped with auxiliary reading means (i.e., a rider, a vernier, or a least significant decimal differentiated by size, shape, or color), the value of the verification scale division “e” is the value of the scale division immediately preceding the auxiliary means. The verification scale division e does not always equal the displayed scale division d. To ensure the correct value for e is used, refer to required markings on the device (see also notes 3 and 4 in Table S.6.3.b.).

² A Class III scale marked “For prescription weighing only” may have a verification scale division (e) not less than 0.01 g.

(Added 1986) (Amended 2003)

³ The value of a verification scale division for crane and hopper (other than grain hopper) scales shall be not less than 0.2 kg (0.5 lb). The minimum number of verification scale divisions, n, shall be not less than 1000.

⁴ On a multiple range or multi-interval scale, the number of verification divisions, n, for each range independently shall not exceed the maximum specified for the accuracy class. The number of verification scale divisions, n, for each weighing range is determined by dividing the scale capacity for each range by the verification scale division, e, for each range. On a scale system with multiple load-receiving elements and multiple indications, each element considered shall not independently exceed the maximum specified for the accuracy class. If the system has a summing indicator, the n_{max} for the summed indication shall not exceed the maximum specified for the accuracy class.

(Added 1997)

⁵ The minimum number of verification scale divisions, n, for a Class III Hopper Scale used for weighing grain shall be 2000.)

[Nonretroactive as of January 1, 1986]

(Amended 1986, 1987, 1997, 1998, 1999, 2003, and 2004 and 20XX)

The middle section of the table was not included for brevity. Notes continue below:

The changes to the header of Table 3 ensure the classification is based on e consistent with the definitions and the principles in T.N.1. The scale division d is not involved in classification. This change should reduce confusion. The

changes to the notes at the bottom of the table again ensure e is correctly referenced instead of d or the “scale division.” Referencing “n” in notes 3, 4, and 5 ensure that it is referring to e since $n = \text{capacity} / e$.

Table S.6.3.a. Marking Requirements					
To Be Marked With ↓	Weighing Equipment				
	Weighing, Load-Receiving, and Indicating Element in Same Housing or Covered on the Same CC¹	Indicating Element not Permanently Attached to Weighing and Load-Receiving Element or Covered by a Separate CC	Weighing and Load-Receiving Element Not Permanently Attached to Indicating Element or Covered by a Separate CC	Load Cell with CC (11)	Other Equipment or Device (10)
Manufacturer’s ID (1)	X	X	X	X	X
Model Designation and Prefix (1)	X	X	X	X	X
Serial Number and Prefix (2)	X	X	X	X	X (16)
Certificate of Conformance Number (CC) (23)	X	X	X	X	X (23)
Accuracy Class (17)	X	X (8)	X (19)	X	
Nominal Capacity (3)(18)(20)	X	X	X		
Value of Scale Division, “d” (3 4)	X	X			
Value of <u>Verification Scale Division</u> , “e” (4 3)	X	X			
Temperature Limits (5)	X	X	X	X	

Note: The remainder of the table was not included for brevity.

The changes to column 1 in the 7th and 8th rows simply reverse the references to the notes in Table S.6.3.b. They reflect the primacy of e in classification, which is addressed in parallel changes to notes 3 and 4 in Table S.6.3.b. (see changes to Table S.6.3.b. below).

Table S.6.3.b.
Notes for Table S.6.3.a. Marking Requirements

1. Manufacturer's identification and model designation and *model designation prefix*.*
[*Nonretroactive as of January 1, 2003]
(Also see G-S.1. Identification.) [*Prefix lettering may be initial capitals, all capitals or all lower case*]
(Amended 2000)
2. *Serial number* [Nonretroactive as of January 1, 1968] and *prefix* [Nonretroactive as of January 1, 1986]. (Also see G-S.1. Identification.)
3. The device shall be marked with the nominal capacity. *The nominal capacity shall be shown together with the value of the verification scale division, "e" (e.g., 15 × 0.005 kg, 30 × 0.01 lb, or capacity = 15 kg, ~~d~~ e = 0.005 kg) in a clear and conspicuous manner and be readily apparent when viewing the reading face of the scale indicator unless already apparent by the design of the device. Each verification scale division value ~~or weight unit~~ with its associated nominal capacity shall be marked on multiple range or multi-interval scales. In the absence of a separate marking of the scale division "d" (see Note 4), the value of the scale division "d" shall be equal to the value of the verification scale division "e."*
[Nonretroactive as of January 1, 1983]
(Amended 2005 and 20XX)
4. *Required only if different from "d": "e." This does not apply to an ungraduated device (equal arm scale) where the graduations do not refer to a fixed weight value.*
[Nonretroactive as of January 1, 1986]
(Amended 20XX)

The original Scales Code adopted 1984 made d the primary mandatory marking but this resulted in confusion. The changes make e the mandatory marking and now requires d only if different from e.

The changes regarding multiple range and multi-interval scales makes the note say what we have always been applying. The intent was for each range or subrange of the instrument to have marking of capacity and e. The "or weight unit" could refer to lb or kg, but that is clearly not the intent.

There is some concern if this might pose problems for existing equipment. If the marking is of the form "capacity 30 lb x 0.01 lb" the workgroup sees not conflict. However, markings in the form "capacity = 30 lb d = 0.01 lb" would cause a conflict as devices using that form would no longer conform with the proposed changes. The workgroup decided to refer this to the scale manufacturers to see if there are any devices in the marketplace that would be affected. We also learned that this might cause a conflict with Measurement Canada as they do see devices with markings of capacity= d=. Note this is not an issue when e ≠ d as both markings is already required by the combination of notes 3 and 4. If necessary, a note with qualification "devices manufactured before January 1, 20XX" could be added to accept existing scales marked with d = provided d = e.

S.1.2.2. Verification Scale ~~Interval~~ Division

The magnitude of the verification scale division e relative to the scale division d for different types of devices is given in Table S.1.2.2. Relative Magnitude of e to d .

Table S.1.2.2. Relative Magnitude of e to d	
<u>Type of device (see Note)</u>	<u>Relative magnitude of e to d</u>
<u>Graduated, without an auxiliary indicating device</u>	<u>$e = d$</u>
<u>Graduated, with an auxiliary indicating device</u>	<u>$e > d$ and e is chosen by the manufacturer according to Table 3. and S.1.2.2.1.</u>
<u>Graduated, and marked for use in special applications (weight classifier)</u>	<u>$e < d$ and e is chosen by the manufacturer according to Table 3. and S.1.2.2.4.</u>

Note: Ungraduated devices, e.g. equal arm balances where the scale graduations do not represent a fixed weight quantity, are not included in this table since they have no scale divisions (d) to permit comparison with (e).

S.1.2.2.1. Class I and II Scales and Dynamic Monorail Scales. – If $e \neq d$, the verification scale ~~interval~~ division “ e ” shall be determined by the expression:

$$d < e \leq 10 d$$

If the displayed scale division (d) is less than the verification scale division (e), then the verification scale division shall be less than or equal to 10 times the displayed scale division.

The value of e must satisfy the relationship, $e = 10^k$ of the unit of measure, where k is a positive or negative whole number or zero. This requirement does not apply to a Class I device with $d < 1$ mg where $e = 1$ mg. If $e \neq d$, the value of “ d ” shall be a decimal submultiple of “ e ,” and the ratio shall not be more than 10:1. If $e \neq d$, and both “ e ” and “ d ” are continuously displayed during normal operation, then “ d ” shall be differentiated from “ e ” by size, shape, color, etc. throughout the range of weights displayed as “ d .”

(Added 1999) (~~Amended 20XX~~)

S.1.2.2.2. Class I and II Scales Used in Direct Sales. – When accuracy Class I and II scales are used in direct sale applications the value of the displayed division “ d ” shall be equal to the value of the verification scale interval “ e .”

[Nonretroactive as of January 1, 2020; to become retroactive as of January 1, 2023]

(Added 2017)

S.1.2.2.3. Deactivation of a “ d ” Resolution. – It shall not be possible to deactivate the “ d ” resolution on a Class I or II scale equipped with a value of “ d ” that differs from “ e ” if such action affects the scale’s ability to round digital values to the nearest minimum unit that can be indicated or recorded as required by paragraph G-S.5.2.2. Digital Indication and Representation.

(Added 2018)

S.1.2.2.4. Class III and IIII Scales. The value of “ e ” is specified by the manufacturer as marked on the device. Except for dynamic monorail scales, “ e ” must be less than or equal to “ d .”

(Added 1999)

~~S.5.3. S.1.2.2.5. Multi-Interval and Multiple Range Scales, Division Value.~~ – On a multi-interval scale ~~and~~ or a multiple range scale, the value of “e” shall be equal to the value of “d.”
(Added 1986) (Amended 1995 and 20XX)

S.1.2.2.6. Class IIII Scales. On Class IIII scales the value of “e” shall equal the value of “d.”
(Added 20XX)

(Add new definition)

auxiliary indicating device. – a means to increase the display resolution of a weighing device, such as a rider or vernier on an analog device, or a differentiated least significant digit to the right of the decimal point on a digital device. [2.20]

(Added 20XX)

Section S.1.2.2. is a key part of understanding application of e and d. The first change was to make references uniform to verification scale “division” as used in all other parts of the code. This section currently uses the term verification scale “interval”. Several additions of the term “scale” were also added to S.1.2.2.1. for clarity. Of note, R76 exempts Class I from the e not greater than 10 d requirement when e = 1 mg or less.

A major addition is the new text and table in T.1.2.2. This would create a parallel section in HB44 to R76 section 3.1.2 and Table 2. This section describes four types of instruments:

1. Graduated without an auxiliary indicating device – most instruments e = d
2. Graduated with an auxiliary indicating device – Class I and II with high resolution e > d
3. Graduated & marked for special applications – weight classifiers (round down instruments) e < d
4. Ungraduated – equal arm balances where graduations don’t refer to fixed weight quantities. No d

These four types also impact application of minimum load in Table 8.

The current S.5.3. was moved to this section as S.1.2.2.5. to keep these paragraphs dealing with the magnitude of e and d together. A new paragraph S.1.2.2.6. was added to address Class IIII where e should always equal d. Now all classes (I, II, III, IIII, and IIII) are covered in S.1.2.2. to clarify relative magnitude of e and d.

The addition of the definition rounds out the expansion of this section

~~S.5.4. S.5.3. Relationship of Minimum Load Cell Verification Interval Value to the Verification Scale Division.~~ – The relationship of the value for the minimum load cell verification scale interval, v_{min} , to the verification scale division, d ~~e~~, for a specific scale using National Type Evaluation Program (NTEP) certified load cells shall comply with the following formulae where N is the number of load cells in a single independent¹ weighing/load-receiving element (such as hopper, railroad track, or vehicle scale weighing/load-receiving elements):

(a) $v_{min} \leq \frac{d^* e}{\sqrt{N}}$ for scales without lever systems; and

(b) $v_{min} \leq \frac{d^* e}{\sqrt{N} \times (\text{scale multiple})}$ for scales with lever systems.

~~[*When the value of the scale division, d, is different from the verification scale division, e, for the scale, the value of e must be used in the formulae above.]~~

~~This requirement does not apply to complete weighing/load-receiving elements or scales, which satisfy all the following criteria:~~

- ~~the complete weighing/load-receiving element or scale has been evaluated for compliance with~~

T.N.8.1. Temperature under the NTEP;

- *the complete weighing/load-receiving element or scale has received an NTEP Certificate of Conformance; and*
- *the complete weighing/load-receiving element or scale is equipped with an automatic zero-tracking mechanism which cannot be made inoperative in the normal weighing mode. (A test mode which permits the disabling of the automatic zero-tracking mechanism is permissible, provided the scale cannot function normally while in this mode.*

[Nonretroactive as of January 1, 1994]

(Added 1993) (Amended 1996, ~~and~~ 2016, ~~and~~ 20XX)

The renumbering resulted from the move of S.5.3. to the S.1.2.2. section as S.1.2.2.5. The other changes correctly reference e instead of d in this section. Technically, v_{min} for load cells corresponds to verification scale division e for weighing instruments. They are accuracy ratings declared by the manufacturer. There is no significant change for the inspector in properly referring to e since for scales where $e = d$ the issue is moot and when $e \neq d$ the section already directed the use of e. With the change the inspector will always use e.

Group 3. Changes to clarify appropriate application of tolerances (Marked Scales)

Table 6.				
Maintenance Tolerances				
(All values in this table are in <u>verification</u> scale divisions “e”)				
Tolerance in Scale Divisions				
	1	2	3	5
Class	Test Load			
I	0 - 50 000	50 001 - 200 000	200 001 +	
II	0 - 5 000	5 001 - 20 000	20 001 +	
III	0 - 500	501 - 2 000	2 001 - 4 000	4 001 +
IIII	0 - 50	51 - 200	201 - 400	401 +
IIIL	0 - 500	501 - 1 000	(Add 1 e for each additional 500 e or fraction thereof)	

The proper reference in this section has always been e, and this is how it has always been interpreted. The current language says “scale divisions” which technically refers to d. This means we weren’t following the Code. The removal of “in Scale Divisions” after Tolerances in the second row was made to provide parallel construction with the header for Test Load. The parenthetical at the top should be sufficient to cover both sections of the table.

The change for Class IIIL was made since e should be used to specify tolerances and we added S.1.2.2.6. requiring that $d = e$ for this class.

T.N.3.4. Crane and Hopper (Other than Grain Hopper) Scales. – The maintenance and acceptance tolerances shall be as specified in T.N.3.1. Maintenance Tolerance Values and T.N.3.2. Acceptance Tolerance Values for Class IIIL, except that the tolerance for crane and construction materials hopper scales shall not be less than 1 ~~e~~ or 0.1 % of the scale capacity, whichever is less.

(Amended 1986 ~~and~~ 20XX)

T.N.4.3. Single Indicating Element/Multiple Indications. – In the case of an analog indicating element equipped with two or more indicating means within the same element, the difference in the weight indications for any load other than zero shall not be greater than one-half the value of the verification scale division (e) (~~d~~) and be within tolerance limits.

(Amended 1986)

The reference to tolerances in T.N.3.4. and T.N.4.3. should follow the principle of expressing tolerances in e.

Group 4. Changes to clarify appropriate application of tolerances (Unmarked Scales)

T.1. General. – The tolerances applicable to devices not marked with an accuracy class shall have the tolerances applied as specified in Table T.1.1. Tolerances for Unmarked Scales.

Note: When Table T.1.1. refers to T.N. sections it shall be accepted that the scale division d on the unmarked scale always equals the verification scale division e.

(Amended 20XX)

Prior to 1984, tolerances were based on percentage of load for most scales. There was no concept of verification scale division e. In the T.N. section all tolerances are expressed in e. The note is added to clarify that d for the T. section is always equal to e from the T.N. section.

The workgroup noted that several specific paragraphs in the T. section for unmarked scales refer to tolerances in terms of d. Those sections are shown below. With the addition of the note to T.1. General, it was decided that it was not appropriate or necessary to change the d to e in these paragraphs.

T.2.2. General. – Except for scales specified in paragraphs T.2.3. Prescription Scales through T.2.8. Railway Track Scales: 2 d, 0.2 % of the scale capacity, or 40 lb, whichever is least.

T.2.4.2. With More Than One-Half Ounce Capacity. – 1 d or 0.05 % of the scale capacity, whichever is less.

T.2.7. Vehicle, Axle-Load, Livestock, and Animal Scales.

T.2.7.1. Equipped With Balance Indicators. – 1 d.

T.2.7.2. Not Equipped With Balance Indicators. – 2 d or 0.2 % of the scale capacity, whichever is less.

T.2.8. Railway Track Scales. – 3 d or 100 lb, whichever is less.

Group 5. Changes to clarify appropriate scale selection (reference Table 8)

Table 8. Recommended Minimum Load		
Class	Value of <u>Verification</u> Scale Division “e” (d or e*)	Recommended Minimum Load <u>in</u> scale divisions “d” (See notes) (d or e*)
I	equal to or greater than 0.001 g	100
II	0.001 g to 0.05 g, inclusive equal to or greater than 0.1 g	20 50
III	All**	20
III L	All	50
IIIH	All	10

*For Class I and II devices equipped with auxiliary reading means (i.e., a rider, a vernier, or a least significant decimal differentiated by size, shape or color), the value of the verification scale division “e” is the value of the scale division immediately preceding the auxiliary means. For Class III and IIIH devices

the value of “e” is specified by the manufacturer as marked on the device; “e” must be less than or equal to “d.”

The displayed scale division d is not always equal to the verification scale division e. To ensure the correct values are used, refer to required markings on the device (see also notes 3 and 4 in Table S.6.3.b.).

For an ungraduated device, the scale division d shall be replaced with the verification scale division e in the last column.

****A minimum load of ~~10 d~~ 5 e is recommended for a weight classifier marked in accordance with a statement identifying its use for special applications.**

In the header, the change in column 2 references e and the change in column 3 references d and directs you to the notes. Currently, the Code references (d or e) in both columns which causes confusion. We’re never sure which one to use. The justification for d in the last column follows below.

It is vital to understand that Table 8. is tied closely to Table 3. You will find that header to the first two columns in both tables, with these changes, will be identical. The workgroup also revised the * note to remove the * and use parallel text to revised note 1 of Table 3. The notes section contains two special exceptions to the general values in column 3 the table. The first directs you to use e in the last column for ungraduated instruments, as these have no d values. The second directs you to use a minimum load of 5 e for weight classifiers. This aligns the value with R76. Note that the use of d for weight classifiers leads to unusual situations. Two weight classifiers with 100 lb capacity and e of 0.05 lb should have the same minimum load. However, they might have very different d values, say 1 lb and 0.2 lb. Declaring minimum load as 10 d for these result in very large differences of 10 lb minimum load for the first instrument and 2 lb for the second. Since $e < d$ for weight classifiers, the minimum load is correctly expressed in e.

Understanding Minimum Load

In R76, minimum load “Min” is included in the principles of classification, see 2.2. below. There are 4 mandatory markings; Class, Max, Min and e. When R76 was translated into HB44 a conscious decision was made to remove Min from the classification and make it a user requirement. Thus, HB44 only has 3 mandatory markings; Class, Capacity, and d. We have already proposed to change the d to e above.

2.2 Principles of the metrological requirements

The requirements apply to all instruments irrespective of their principles of measurement.

Instruments are classified according to:

- the verification scale interval, representing absolute accuracy; and
- the number of verification scale intervals, representing relative accuracy.

The maximum permissible errors are in the order of magnitude of the verification scale interval. They apply to gross loads and when a tare device is in operation they apply to the net loads. The maximum permissible errors do not apply to calculated net values when a preset tare device is in operation.

A minimum capacity (Min) is specified to indicate that use of the instrument below this value is likely to give rise to considerable relative errors.

In R76, the issue of instrument accuracy is focused on Class, Max and e, parallel to HB44. Absolute accuracy in terms of e and relative accuracy in terms of n. When the load is very small, i.e. less than Min, it might appear that R76 is addressing the large relative errors resulting in 1 e tolerance for some small number of e in load. However, this is not the case. The distinction is that Min applies to use of the instrument and not to testing of the instrument.

In testing under R76 tolerances, rounding errors are eliminated (see 3.5.3.2.). In practice this usually means error weights are used to resolve the instrument errors to at least 0.2 e (NTEP generally uses 0.1 e). In addition, R76 expects that instrument divisions are relatively uniform throughout the series. In order to get a +1 e error at 1 e load and still meet the requirement that the zero division be +/- 0.5 division wide, would require the 1 e divisions be 0 e wide (i.e. be skipped). To visualize in analog, imagine an indicator that starts at zero and jumps immediately to the 2 graduation.

A load of 1 e would indicate 2 e. Likewise a load of 2 e would indicate 3 e and this pattern would repeat until the tolerance breakpoint, a load of 500 e would indicate 501 e. Then the second graduation after the break point would be skipped, i.e. the 502 e graduation. A load of 501 e would indicate 503 e with a +2 e error. All the loads up to 20,000 e would now show a +2 e error. Instruments obviously should not, and DO NOT, operate that way.

If we assume instrument divisions are uniform, as R76 does, then the divisions should be accurate to about the relative % of the accuracy class. For Class II in the first step this is 0.02%. Thus at 20 e load the maximum expected error (after eliminating rounding) should be in the order of 0.004 e, and not the 1 e permitted in the tolerance structure. So, what relative error can R76 be addressing when dealing with Min?

When an instrument is used in commerce, it is the rounding of the indication to ½ scale division that results in large relative errors. Consider a cannabis sale of 1.05 g when the division size is 0.1 g. The instrument must round off to either 1.0 g or 1.1 g. Either one produces an error in the weight of 0.05 g. That's 4.8% relative error in the weight (0.05 g / 1.05 g) with an instrument that's supposed to be accurate to 0.02%. It is this rounding error "in use" that produces the large relative errors addressed in Min in R76 and the minimum load in HB44. This rounding error is a function of d, the displayed scale division, and not e. It is not a tolerance issue.

The confusion comes from the presentation of Min in terms of e in the last column of R76 Table 3. The table in R76 has an additional column for Min not found in HB44. In HB44 it has been relocated to Table 8. Looking closely at Table 8, you will find that the first two columns correspond to the first two columns in Table 3 in HB44. So why does R76 express this column in e instead of d? I suspect they did it because all other values in Table 3 are in e. For instruments where e = d, the issue is moot. Note however, that R76 reveals the ties to d for the Class I and II instruments with an auxiliary indicating device (differentiated least significant digit). In 3.4.3. R76 directs that d replace e in the Min column of Table 3 for instruments with an auxiliary indicating device.

On an instrument where e = 10 d, we can create the same scenario as before but now with a load of 1.005 g. The instrument must now round to either 1.00 g or 1.01 g. The rounding error is now 0.50% of the weight (0.005 / 1.005). That is 10 times smaller at the same 20 e load.

Returning to the four types of instruments from revised S.1.2.2. and applying revised Table 8.:

- | | |
|--|-------------------|
| 1. Graduated without an auxiliary indicating device: | minimum load in d |
| 2. Graduated with an auxiliary indicating device: | minimum load in d |
| 3. Graduated and marked for special use (weight classifier): | minimum load 5 e |
| 4. Ungraduated (equal arm scales): | minimum load in e |

Group 6. Changes to correctly reference to e or d as appropriate.

S.1.1.1. Digital Indicating Elements.

(a) A digital zero indication shall represent a balance condition that is within $\pm \frac{1}{2}$ the value of the verification scale division.

(b) *A digital indicating device shall either automatically maintain a "center-of-zero" condition to $\pm \frac{1}{4}$ verification scale division or less, or have an auxiliary or supplemental "center-of-zero" indicator that defines a zero-balance condition to $\pm \frac{1}{4}$ of a verification scale division or less. A "center-of-zero" indication may operate when zero is indicated for gross and/or net mode(s).
[Nonretroactive as of January 1, 1993]*

(c) *For electronic cash registers (ECRs) and point-of-sale systems (POS systems) the display of measurement units shall be a minimum of 9.5 mm (3/8 inch) in height.
[Nonretroactive as of January 1, 2021]*

(Added 2019)

(Amended 1992, 2008, ~~and~~ 2019, and 20XX)

The changes correctly reference e in this section as this is an issue of ensuring the zero indication is accurate to $\frac{1}{4} e$. Hence it is a tolerance properly expressed in terms of e.

T.N.9. Radio Frequency Interference (RFI) and Other Electromagnetic Interference Susceptibility. – The difference between the weight indication due to the disturbance and the weight indication without the disturbance shall not exceed one verification scale division (~~d~~) (e); or the equipment shall:

- (a) blank the indication; or
- (b) provide an error message; or
- (c) the indication shall be so completely unstable that it cannot be interpreted, or transmitted into memory or to a recording element, as a correct measurement value.

The tolerance in T.N.9. Radio Frequency Interference (RFI) and Other Electromagnetic Interference Susceptibility is to be applied independently of other tolerances. For example, if indications are at allowable basic tolerance error limits when the disturbance occurs, then it is acceptable for the indication to exceed the applicable basic tolerances during the disturbance.

(Amended 1997 and 20XX)

This is a tolerance for reaction to a disturbance and is properly expressed in e.

Group 7. Identify appropriate application of code sections (in order of appearance)

When the paragraph references d it is referring to the actual scale division and the concern is how the instrument operates. When the paragraph references e it is referring to the verification scale division and the concern is in classification of the instrument or in accuracy of the displayed values.

The sections in the table below currently correctly reference e or d as appropriate. The text of each section is not included for brevity. The justification may help explain the general rules above.

Code Section	Applies to	Justification
G-S.5.2.2.(c)	d	Rounding is a function of instrument operation not accuracy
G-S.5.2.2.(d)	d	Requires “d” to be an indicated zero and all digits to the left of “d” to be zero when $d < 1$. Requires “d” to be an indicated zero and all digits to the right of “d” to be zero when $d > 5$.
S.1.2.	d	1, 2, or 5 refers to d which is rounded. When $e \neq d$ refer to section S.1.2.2. for value of e.
S.1.2.1	d	Refers to rounded values of d.
S.1.2.3.	e	This is a classification issue. It ensures accuracy of the piece counts.
S.1.7.(b)	e	This is a classification issue addressing maximum indication above capacity.
S.2.1.2.	d	They must be in terms of d since stability of zero setting applies to d.
S.2.1.3.(all)	d	These limit the window for action of AZT. They must be in terms of d since zero setting applies to d.
S.2.3.	d	Tare division must equal smallest increment displayed.
T.N.7.	d	Discrimination requires an instrument to discriminate to the displayed scale division (zone of uncertainty). This relates to the rounding of the smallest increment.
UR.3.7.	d	Minimum load is correctly expressed in d. (see Group 5 above)
UR.3.10.	e	As written, this is clearly e. (See issues for additional study)

PART 3. Issues Identified as Requiring Additional Study (outside the scope of this workgroup)

A. The workgroup was in consensus that we should expand requirements in S.2.1.2. relating to semi-automatic zero to apply to all scales and not just scales used in direct sale. In first place, suitability is a User Requirement and not a specification. Second, correct operation to set zero should be applicable to all digital instruments as it is in R76.

B. The application of tolerances to net loads has always been assumed, even before the Scales Code adoption in 1984. Comparing T.2. for unmarked scales and T.N.2.1. for marked scales reveals important differences particularly regarding net loads. As written, T.N.2.1. exempts calculated net, but it appears to apply to both semi-automatic tare and preset tare. A comparison to R76 shows that OIML limits applicability of tolerances. Their MPE's do not apply to calculated net values or when preset tare (keyboard or programmed tare) is in operation (section 2.2). It appears net loads have MPE's applied only when the net zero is set in compliance with S.1.1.1.(b) which requires accuracy of zero to ¼ division. This cannot be assured with preset tare or when net is based on two gross values. This has further ramifications to any case where all three (gross, tare and net) values are indicated/recorded for a transaction. OIML requires the gross and net weights be accurate but does not apparently require that the equation gross – tare = net be in mathematical agreement due to rounding issues. Note that in most transactions, the customer only gets one or two of the gross, tare or net values. Rounding issues do not arise for this reason. This may impact a current issue before NCWM dealing with printing tare on POS transaction receipts. Consider a POS transaction where the customer saw 1.02 lb on the weight display and sees 1.00 lb net and 0.03 lb tare. These are all accurate weights (and correct per R76) but the numbers don't add up. The customer will claim they were overcharged by 0.01 lb since $1.02 \text{ lb} - 0.03 \text{ lb} = 0.99 \text{ lb}$.

C. The resolution of errors in testing scales was identified as an issue. The original proposal included a revision requiring resolution of error to at least 0.2 e. R76 specifically declares that errors be resolved to at least 0.2 e to eliminate rounding error. HB44 has no such provision and it might appear that rounding error is included in the tolerance. Instead of tolerance steps of 1, 2, etc., it could be argued that the tolerances are 1.5, 2.5, etc. as the result of direct reading. NTEP uses the R76 approach exclusively in testing, but it has no technical basis in the Code. There are obvious issues involved in using error weights in the field. The challenge is that you either eliminate rounding in determining tolerances or you don't. We have two standards at play at present. In addition, it can be argued that Class IIIIL instruments are already high resolution somewhat similar to Class I and II instrument with $e > d$. Class IIIIL devices have enough resolution to read errors to 0.2 e or 0.1 e of the equivalent Class III instrument without using error weight.

D. The UR.3.10. requirement that transactions from dynamic monorail scales be based on e raises issues. It was discussed since it involves both e and d. The displayed scale divisions equal to e (i.e. 10 d) are not normally rounded. If $e = 10 d$ then the rounding point is not 5 up/4 down, as it is for d, but rather 9.5 up/0.5 down. Does this requirement mean the scale design has to produce a properly rounded value for the transaction that may be different from the display, e.g. 943.7 lb to d of 0.1 lb now must be recorded for the transaction as 944 lb? In addition, in brief discussion, it seemed there were many ways this could be interpreted. The workgroup concluded it would be beneficial to open some discussions with USDA and the manufacturers to explore some of these questions. This also addresses similar issues to the proposal to delete S.1.2.2.2. where questions of using e or d are impacting high precision scales in cannabis and jeweler's sales.

